

10" Cabinet Saw
Sliding Table Model: 10-110
Cast Table Wings Model: 10-050

RIKON
POWER TOOLS



Owner's Manual

Record the serial number and date of purchase
in your manual for future reference.

Serial number: _____

Date of purchase: _____

Part #10-110M2

For more information:
www.rikontools.com or info@rikontools.com
For Parts or Questions:
techsupport@rikontools.com or 877-884-5167

Operator Safety: Required Reading

IMPORTANT! Safety is the single most important consideration in the operation of this equipment. **The following instructions must be followed at all times.**

There are certain applications for which this tool was designed. We strongly recommend that this tool not be modified and/or used for any other application other than that for which it was designed. If you have any questions about its application, do not use the tool until you have contacted us and we have advised you.

General Safety Warnings

KNOW YOUR POWER TOOL. Read the owner's manual carefully. Learn the tool's applications, work capabilities, and its specific potential hazards.

⚠ DANGER



ALWAYS GROUND ALL TOOLS.

If your tool is equipped with a three-pronged plug, you must plug it into a three-hole electric receptacle. If you use an adapter to accommodate a two-pronged receptacle, you must attach the adapter plug to a known ground. Never remove the third prong of the plug.

ALWAYS AVOID DANGEROUS ENVIRONMENTS.

Never use power tools in damp or wet locations. Keep your work area well lighted and clear of clutter.

⚠ DANGER



ALWAYS REMOVE THE ADJUSTING KEYS AND WRENCHES FROM TOOLS AFTER USE.

Form the habit of checking to see that keys and adjusting wrenches are removed from the tool before turning it on.

ALWAYS KEEP YOUR WORK AREA CLEAN. Cluttered areas and benches invite accidents.

⚠ DANGER



ALWAYS KEEP VISITORS AWAY FROM RUNNING MACHINES.

All visitors should be kept a safe distance from the work area.

ALWAYS MAKE THE WORKSHOP CHILDPROOF.

Childproof with padlocks, master switches, or by removing starter keys.

⚠ DANGER



NEVER OPERATE A TOOL WHILE UNDER THE INFLUENCE OF DRUGS, MEDICATION, OR ALCOHOL.

⚠ DANGER



ALWAYS WEAR PROPER APPAREL.

Never wear loose clothing or jewelry that might get caught in moving parts. Rubber-soled footwear is recommended for the best footing.

⚠ DANGER



ALWAYS USE SAFETY GLASSES AND WEAR HEARING PROTECTION.

⚠ DANGER



NEVER OVERREACH.

Keep your proper footing and balance at all times.

⚠ DANGER



NEVER STAND ON TOOLS.

Serious injury could occur if the tool is tipped or if the cutting tool is accidentally contacted.

⚠ DANGER**ALWAYS DISCONNECT TOOLS.**

Disconnect tools before servicing and when changing accessories such as blades, bits, and cutters.

**ALWAYS AVOID ACCIDENTAL STARTING.**

Make sure switch is in "OFF" position before plugging in cord.

NEVER LEAVE TOOLS RUNNING UNATTENDED.**⚠ DANGER****ALWAYS CHECK FOR DAMAGED PARTS.**

Before initial or continual use of the tool, a guard or other part that is damaged should be checked to assure that it will operate properly and perform its intended function. Check for alignment of moving parts, binding of moving parts, breakage of parts, mounting, and any other conditions that may affect its operation. A guard or other damaged parts should immediately be properly repaired or replaced.



Table Saw Safety Rules

1. Always wear eye protection.
2. Keep hands away from the saw blade while machine is running.
3. Always use blade guard during normal cutting operations.
4. Always use splitter during normal cutting operations.
5. Use push sticks when ripping narrow stock.
6. Always use fence while ripping and miter gauge while cross-cutting.
7. Never reach over or behind saw blade while machine is running.
8. Do not remove cut-off or jammed pieces until blade has come to a full stop.
9. Disconnect machine from power source before making repairs or adjustments.
10. Do not expose saw or power cord to water or use in damp locations.

SAVE THESE INSTRUCTIONS.
Refer to them often.

Table of Contents

Safety Warnings.....	2-3
Table Saw Safety Rules	3
Specifications	4
Contents of Package	5
Unpacking and Checking Contents.....	5
Loose Parts	6
Getting To Know Your Table Saw	7
Assembly	8
Installing the Right Table Wing.....	8
Installing the Optional Left Table Wing.....	8
Installing the Optional Sliding Table	9
Installing Front Fence Rail	9
Rear Fence Rail Installation.....	9-10
Mounting the Fence Guide Bar.....	10
Installing Fence to Guide Bar	10
Installing the Fence Scale.....	11
Leveling Fence to Saw Table	11
Squaring Fence to Table	12
Fence Cursor Adjustment	12
Blade Guard and Splitter Installation.....	13
Blade Installation and Removal.....	14
Leveling the Blade Insert	14
Operation	15
Raising and Tilting the Saw Blade.....	15
Switch Operation.....	15
Maintenance	16
Wiring Diagram	16
Troubleshooting	17
Electrical Requirements.....	18
Parts Diagram	19-21
Parts List	22-23
Warranty	26

Specifications

Blade Diameter	10"
Maximum Depth of Cut	3-1/8"
Maximum Depth of Cut at 45°	2-1/8"
Table in Front of Blade	13-7/8"
Maximum Width of Dado	29/32"
Blade Speed	4300RPM
Motor Power	3HP
Volts	230V / 60Hz
Current	13A
Height	37-1/2"
Net Weight	615 lbs

Content of Package

Model 10-050 10" Table Saw is shipped complete in three boxes.

1. Unpacking and Checking Contents

- Separate all "loose parts" from packaging materials and check each item with "Table of Loose Parts" to make sure all items are accounted for, before discarding any packaging material.
- With the help of another person, unbolt the table saw from the packing pallet. Properly lift the table saw off the packing pallet and place on level floor.
- Remove protective oil that is applied to the table. Use any ordinary house hold type grease or spot remover.
- Apply a coat of paste wax to the table to prevent rust. Wipe all parts thoroughly with a clean dry cloth.

2. Loose Parts

TABLE OF LOOSE PARTS

Item	Part Name	Qty
A	Table Saw Assembly	1
B	Fence Assembly	1
C	Right Extension Wing	1
D	Blade Guard Assembly	1
E	Blade Guard Support	1
F	Owner's manual	1
G	Bag of loose parts	1

Box #1

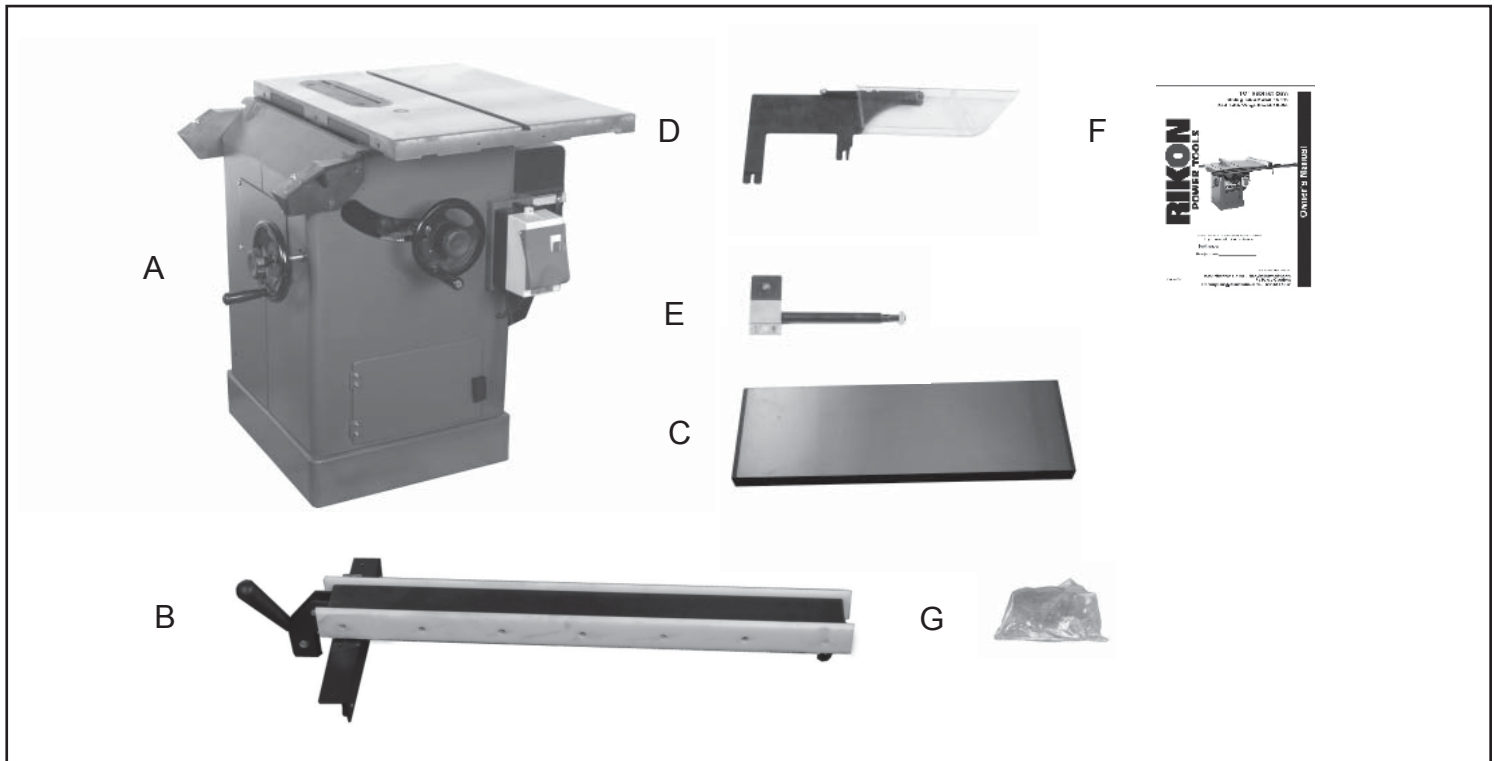

Loose Parts Continued

TABLE OF LOOSE PARTS

Item	Part Name	Qty
A	Rear Guide Rail	1
B	Front Guide Rail	1

Box #2



TABLE OF LOOSE PARTS

Item	Part Name	Qty
A	Left Extension Wing	1
B	Bag of loose parts	1

Box #3



Getting To Know Your Table Saw

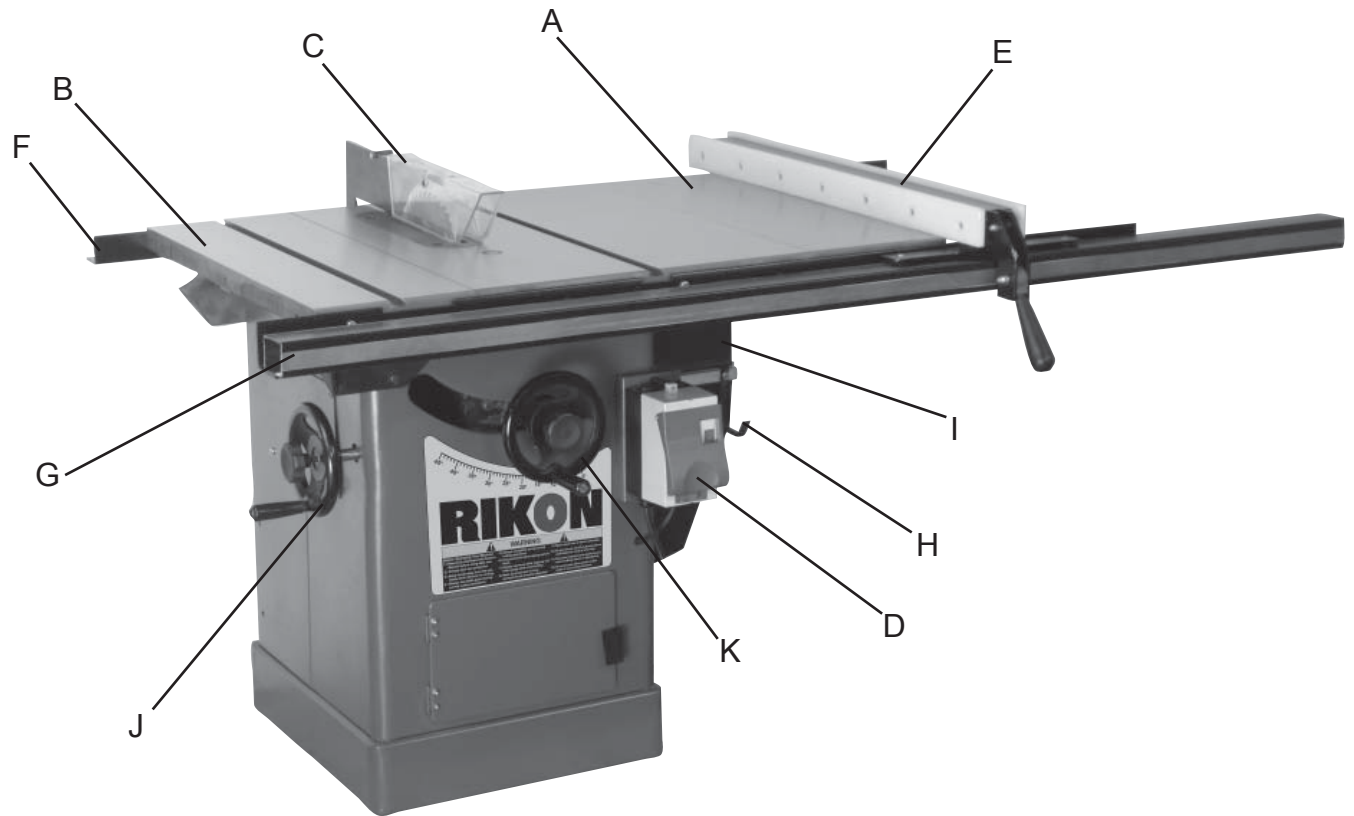

- A. Right Extension Wing
- B. Left Extension Wing
- C. Blade Guard Assembly
- D. Switch
- E. Fence Assembly
- F. Rear Rail
- G. Front Rail

- H. Tool Holder
- I. Motor Cover
- J. Blade Tilting Handwheel
- K. Blade Raise/down Handwheel

Installing the Right Table Wing

1. Mount the cast iron table wing using three M10x30 hex head bolts and three M10 flat washers. Figure 1.

With assistance hold the extension wing up to the table, and insert the bolts and washers. Finger tighten only.

NOTE: If assistance is not available, hold the wing in vertical position up to the saw table, insert the middle screw and lock washer finger tight, then pivot the wing to level position. Insert the other two screws and washers finger tight.

2. Align table wing toward the front edge of the saw table until the two faces are flush. Figure 2.

3. Level table wing with the saw table across its entire width, using a straight edge and hammer with rubber hammer (or block of wood). Figure 3.

As each section of the table wing becomes flush with the table, tighten the screw under that area. Continue until all three screws are fully tightened. Check with straight edge and adjust as needed. Figure 4.

Installing the Optional Left Wing

The optional left cast iron table wing with miter slot is used in place of the optional slide table. Please refer to the instructions above for proper installation.

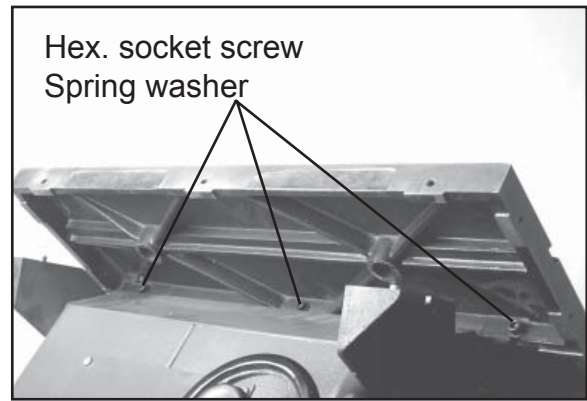

Figure 1

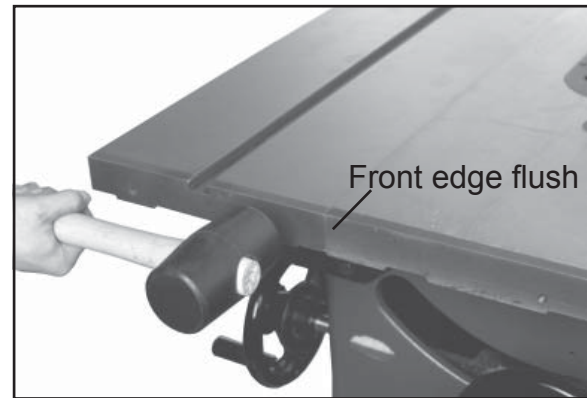

Figure 2

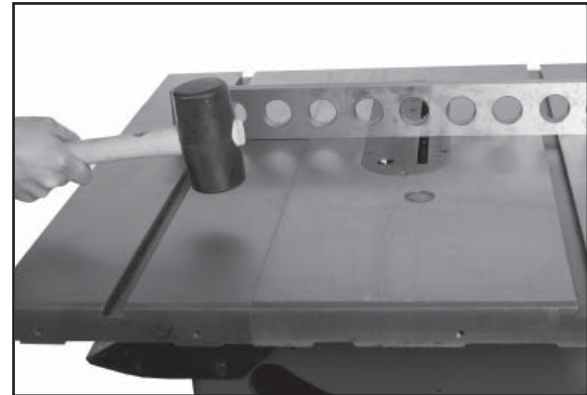

Figure 3

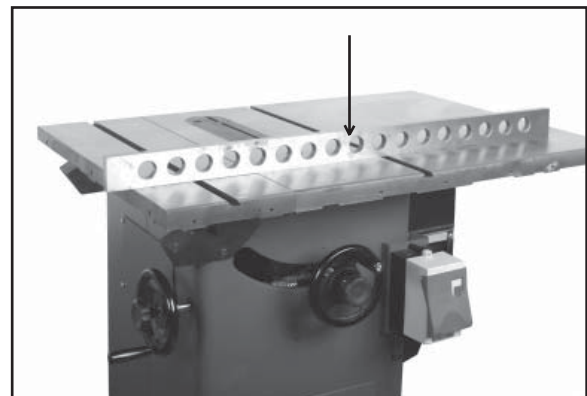

Figure 4

Assembling the Optional Sliding Table

Please refer to the Sliding Table Attachment manual located in the separate shipping carton for proper installation procedures.

Installing Front Fence Rail

1. Identify the front rail (E), which is the larger “L” shaped bar with the countersunk mounting holes facing front.

NOTE: The front fence rail can be mounted differently depending on the use of the cast table wing or the sliding table attachment. When using the table wing the front fence rail should be installed as described below. Please refer to the Sliding Table Attachment manual for proper placement of the front fence rail. Figure 5.

2. Align the “L” shaped bar so the left notch (H) matches the miter slot on the left extension wing.

3. Secure the front rail (E) to the table (G) and table wings (F) with five countersunk head screws (A). Tighten just enough to hold the rail next to the table but keep loose enough to allow height adjustment. Figure 6.

4. When the Front Rail has been correctly positioned, tighten all mounting screws securely with the 5MM L wrench provided.

Rear Fence Rail Installation

1. Identify the rear fence rail, which is the smaller “L” shaped bar. Place against the table and align as shown. Figure 7.

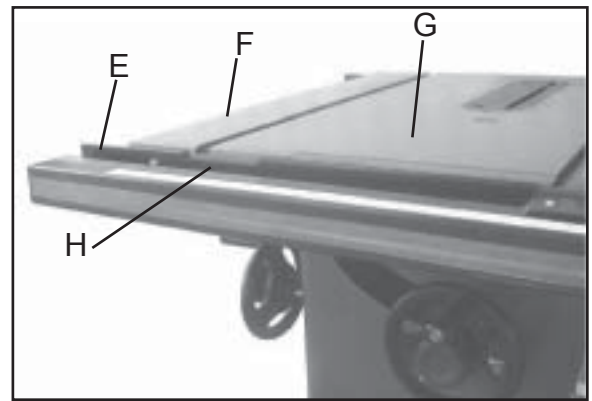

Figure 5

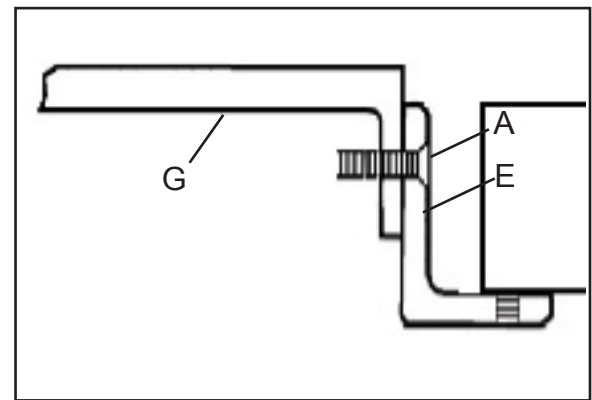

Figure 6

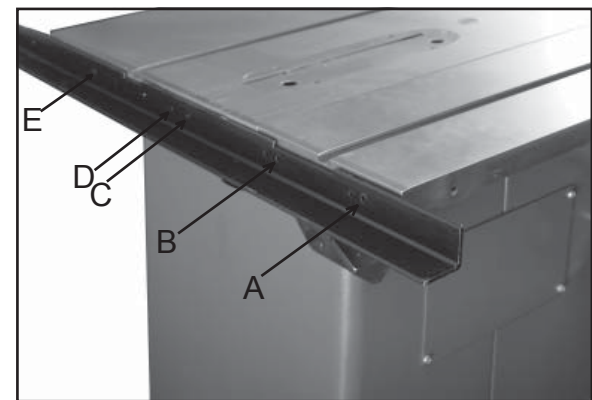

Figure 7

Rear Fence Rail Installation Continued

NOTE: The rear fence rail can be mounted differently depending on the use of the cast table wing or the sliding table attachment. When using the table wing the rear fence rail should be installed as described below.

Please refer to the Sliding Table Attachment manual for proper placement of the back fence rail.

2. Align the rear fence rail so the right notch matches the miter slot on the left extension wing. (A-Fig. 9)

3. Secure the rear fence rail to the tapped holes in the saw table and table wings with five M8 hex head cap screws. Tighten screws securely with a 6MM L wrench. Figures 8&9.

Installing Fence to the Guide Bar

Lay the fence onto the guide bar. The lock lever has three functional positions as shown in Figure 10:

- A. The upright position permits mounting and removal of fence from the saw.
- B. The unlock position permits easy fence positioning.
- C. The lower position locks the fence to the front rail.

Installing the Fence Scale

NOTE: The fence scale can be mounted differently depending on the use of the cast table wing or the sliding table attachment. When using the table wing the fence scale should be installed as described below. Please refer to the Sliding Table Attachment manual for proper placement of the fence scale.

1. Lay the fence onto the guide bar and slide fence up against the saw blade. With the fence in the locked position, pull back 1/4" of the adhesive backing and slide the fence scale under the cursor.

2. Line up the "zero" position on the fence scale with the line on the cursor. Figure 11.

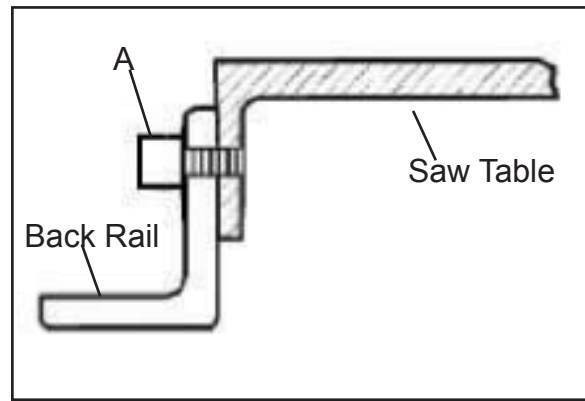

Figure 8

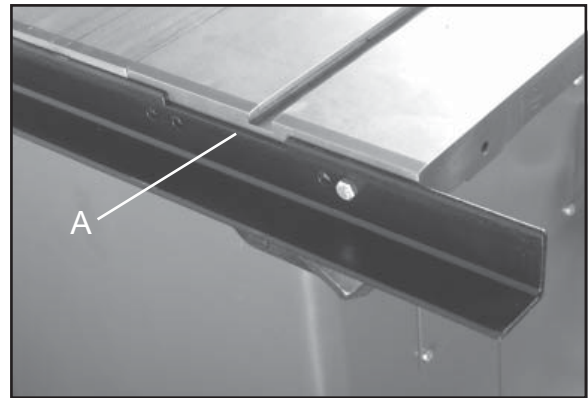

Figure 9

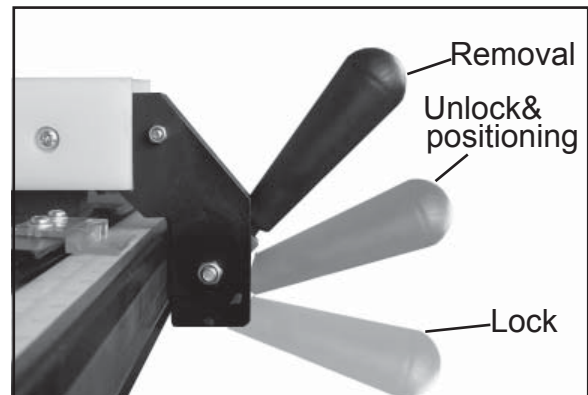

Figure 10



Figure 11

Leveling Fence to the Saw Table

4. View the fence from the left side of the saw (Figure 12). Look for the space between the table and the fence bottom to be equal along the entire length of the fence.

5. If the fence is highest at the rear of the table, lower the nylon pad at the rear of the fence using a 10MM wrench.

6. If the fence is highest at the front of the table, raise the two nylon pads on the front of the fence with a 4MM L wrench. Raise each side equally as it could cause the fence to be out of square with the table. (C,D, Fig. 13.)

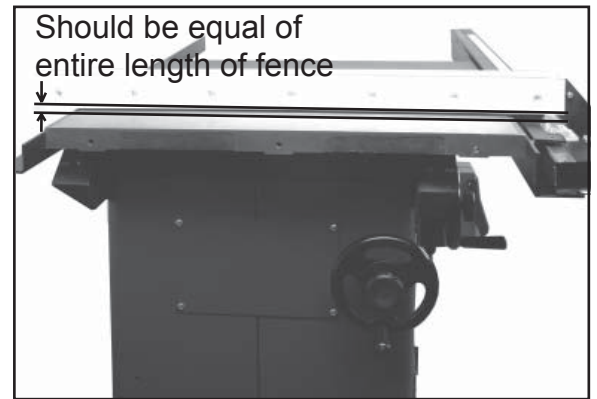

Figure 12

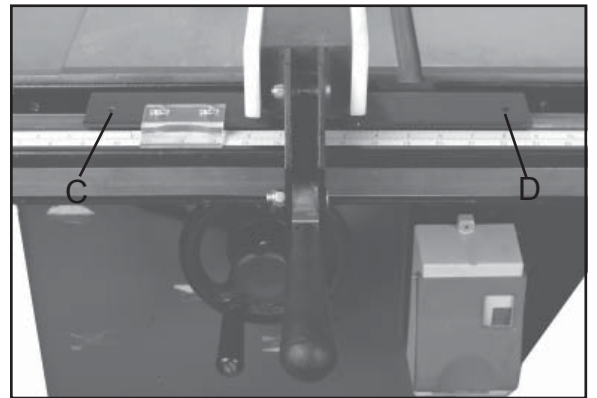

Figure 13

Adjusting Fence Parallel to the Miter Slot

1. Place the fence next to the outside edge of the right miter slot and lock it.
2. The fence should be even with the miter slot from front to back.
3. If the fence is not even along the length of the miter slot, unlock the fence, remove it and turn upside down.
4. Adjust one of the two set screws (A, Fig. 14) until the fence is even with the miter slot edge along its entire length when locked.

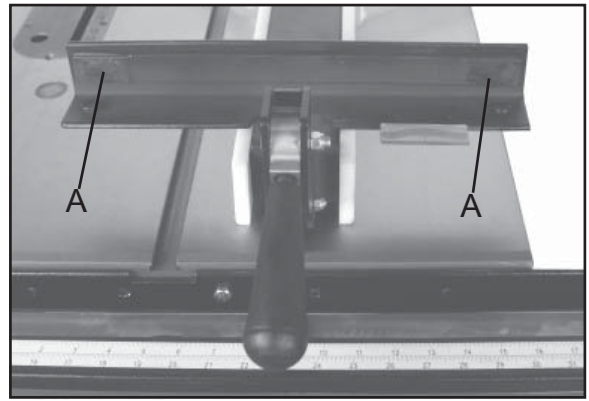

Figure 14

Squaring Fence 90° to the Table

1. Place the fence on the saw table and lock it.
2. Place a square (A, Fig. 15) on the table next to the fence. The fence should be 90° to the table.
3. If adjustment is necessary, unlock the fence, and turn one of the two nylon adjustment screws (B, Fig. 15) until the fence is 90° to the table.
4. Lock the fence and check the adjustment again.

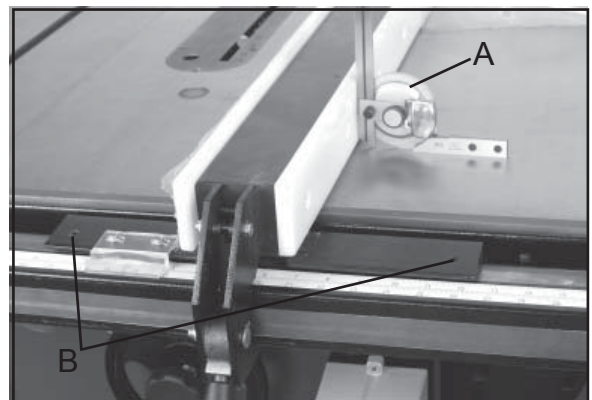

Figure 15

Fence Cursor Adjustment

1. Lock the fence down 3" from the saw blade.
2. Measure off of the blade and check if it correct with fence scale.
3. If adjustment is needed loosen the two screws on the cursor and align as needed. Tighten screws.
4. If further adjustment is needed loosen the mounting bolts to the guide tube and shift it left to right as needed. Figure 16.



Figure 16

Blade Guard and Splitter Installation

1. Remove table insert and raise the saw blade, then loosen the hex head cap screw (A, Fig.17) located on the rear table trunnion assembly. Figure 17.

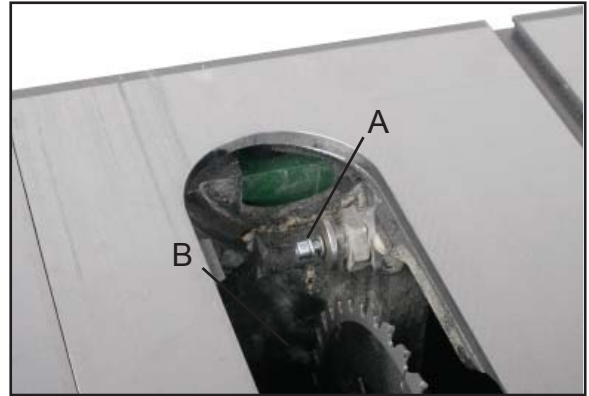

Figure 17

2. Install guard post through slot at rear of saw and into the hole in the trunnion. Fasten into place with one 8MM square nut (B, Fig.17) with 14MM wrench. Figure 18.



Figure 18

3. The splitter support bracket must be installed on to guard post as shown. Figure 19.



Figure 19

4. Slide the guard into place and tighten the hex head cap screw on the rear trunnion assembly and tighten the nut on the splitter support bracket. Figure 20.



Figure 20

Blade Installation and Removal

WARNING! Please disconnect saw from the power source. Make sure to use caution while work with or around saw blade.

1. Raise the blade arbor and make sure the arbor is at the zero degree position.
2. To install during initial assembly, remove the arbor nut (A, Fig. 21) and flange (B, Fig. 21) from arbor.
3. Place blade (C, Fig. 21) on arbor shaft making sure teeth point down at the front of the saw. Replace flange and arbor nut, tightening arbor nut toward the rear of the machine.
4. To remove the blade place a wood scrap in the blade's teeth at the front of the machine. Hold the block of wood in such a way that if it slips or the blade turns, your hand will not contact the blade. Loosen arbor nut by pulling wrench toward the front of the machine.(Fig. 22)
5. Reverse operation to remove blade.

Leveling the Blade Insert

1. Adjust table insert (A, Fig. 23) flush with table by turning four leveling screws (B, Fig. 23).
2. Use a straight edge (C, Fig. 23) to make sure the insert is flush with the table.

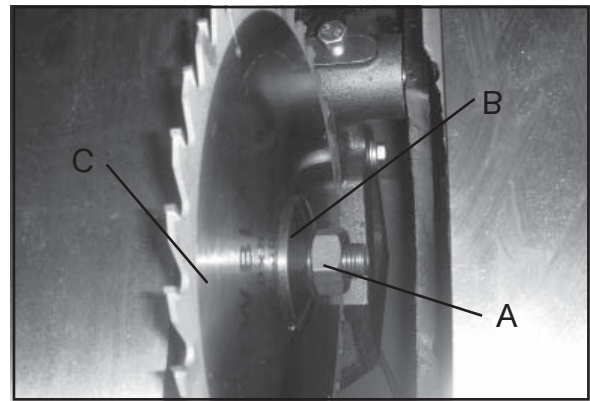

Figure 21

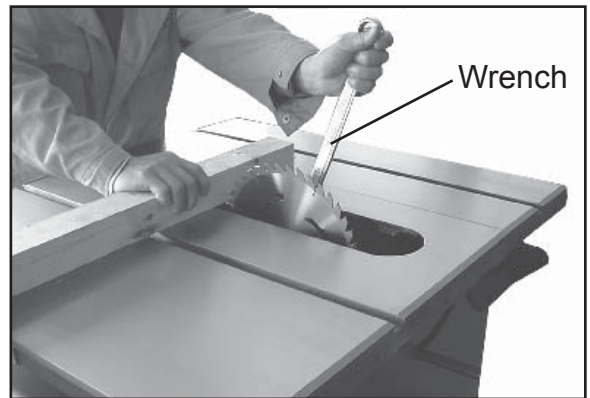

Figure 22

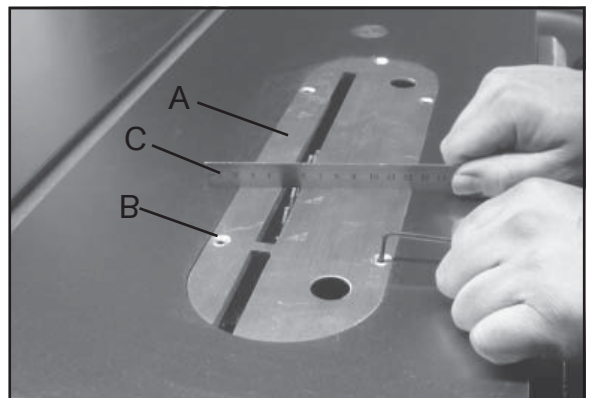

Figure 23

Raising and Tilting the Saw Blade

1. To raise or lower the saw blade, loosen the lock knob (A, Fig. 24) and turn the handwheel (B, Fig. 24) on the saw front until desired height is reached. Tighten lock knob. The blade should be adjusted 1/8" to 1/4" above the top surface of the material being cut.

2. To tilt the saw blade, loosen the lock knob (C, Fig. 24) found on the left side of the table saw and turn handwheel (D, Fig. 24) until desired angle is obtained, then tighten lock knob.

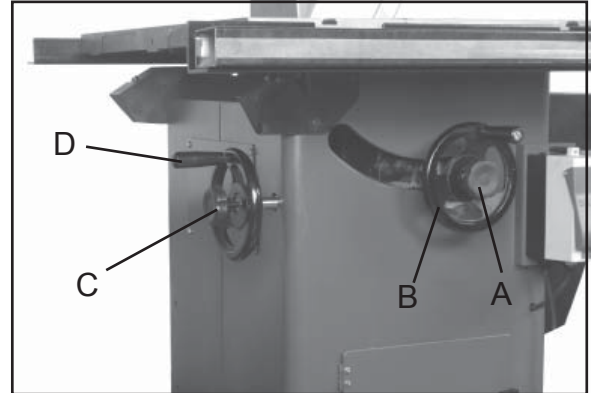

Figure 24

Switch Operation

NOTE: The switch has a built in safety feature and will not restart if the breaker is tripped.

1.) To start the saw, depress the green button at the top of the switch (A, Fig. 25).

2.) To shut the saw off, hit the large stop paddle with your hand. For hands free operation, you can bump the large stop paddle with your knee (B, Fig. 25).

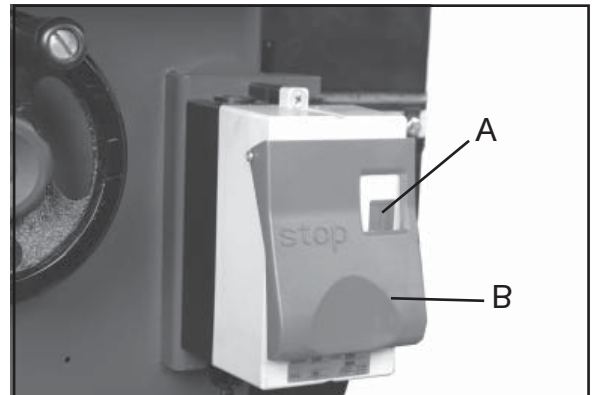

Figure 25

Maintenance

Caution! BEFORE CLEANING OR CARRYING OUT MAINTENANCE WORK, DISCONNECT THE MACHINE FROM THE POWER SOURCE (WALL SOCKET). NEVER USE WATER OR OTHER LIQUIDS TO CLEAN THE MACHINE. USE A BRUSH. REGULAR MAINTENANCE OF THE MACHINE WILL PREVENT UNNECESSARY PROBLEMS.

Keep the table clean to ensure accurate cutting.

Keep the outside of the machine clean to ensure accurate operation of all moving parts and prevent excessive wear.

Keep the ventilation slots of the motor clean to prevent it from overheating.

Keep the inside (near the saw blade, etc.) clean to prevent accumulation of dust.

Wiring Diagram

WARNING! This machine must be grounded. Replacement of the power supply cable should only be done by a qualified electrician.

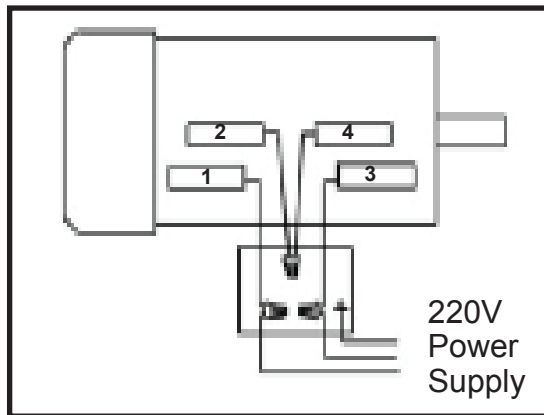

Troubleshooting

WARNING!

FOR YOUR OWN SAFETY, ALWAYS TURN OFF AND UNPLUG THE MACHINE BEFORE CARRYING OUT ANY TROUBLESHOOTING.

SYMPTOM	POSSIBLE CAUSE	CORRECTIVE ACTION
Motor will not start.	<ol style="list-style-type: none"> 1. Low voltage. 2. Open circuit in motor or loose connections. 	<ol style="list-style-type: none"> 1. Check power line for proper voltage. 2. Inspect all lead connections on motor for loose or open connections.
Motor will not start; fuses or circuit breakers blow.	<ol style="list-style-type: none"> 1. Short circuit in line cord or plug. 2. Short circuit in motor or loose connections. 3. Incorrect fuses or circuit breakers in power line. 	<ol style="list-style-type: none"> 1. Inspect cord or plug for damaged insulation and shorted wires. 2. Inspect all connections on motor for loose or shorted terminals or worn insulation. 3. Install correct fuses or circuit breakers.
Motor overheats.	<ol style="list-style-type: none"> 1. Motor overloaded. 2. Air circulation through the motor restricted. 	<ol style="list-style-type: none"> 1. Reduce load on motor. 2. Clean out motor to provide normal air circulation.
Motor stalls (resting in blown fuses or tripped circuit).	<ol style="list-style-type: none"> 1. Short circuit in motor or loose connections. 2. Low voltage. 3. Incorrect fuses or circuit breakers in power line. 4. Motor overloaded. 	<ol style="list-style-type: none"> 1. Inspect connections on motor for loose or shorted terminals or worn insulation. 2. Correct the low voltage conditions. 3. Install correct fuses or circuit breakers. 4. Reduce load on motor.
Machine slows when operating. Blade is not square with the slot or fence is not square to blade.	<ol style="list-style-type: none"> 1. Applying too much pressure to workpiece. 2. Belts loose. <ol style="list-style-type: none"> 1. Blade is warped. 2. Table top is not parallel to blade. 3. Fence is not parallel to blade. 	<ol style="list-style-type: none"> 1. Feed workpiece slower. 2. Tighten belts. <ol style="list-style-type: none"> 1. Replace blade. 2. Make table parallel to blade. 3. Make fence parallel to blade.
Fence hits table top when sliding on to the table.	<ol style="list-style-type: none"> 1. Front rail is bolted too low on table. 2. Rear rail is bolted too low on the table. 	<ol style="list-style-type: none"> 1. Raise front rail. 2. Raise rear rail.
Blade does not reach 90°.	<ol style="list-style-type: none"> 1. 90° stop bolt is out of adjustment. 2. Pointer bracket is hitting before the blade reaches 90°. 	<ol style="list-style-type: none"> 1. Adjust 90° stop bolt. 2. Tilt down the right side of the pointer bracket until the blade can reach 90°.
Blade hits insert at 45°	<ol style="list-style-type: none"> 1. Hole in insert is inadequate. 2. Table out of alignment. 3. Blade position is incorrect. 	<ol style="list-style-type: none"> 1. File or mill the hole in the insert. 2. Align table. 3. Adjust blade position.

For parts or technical questions contact: techsupport@rikontools.com or 877-884-5167.

Electrical Requirements

In the event of a malfunction or breakdown, grounding provides a path of least resistance for electric current to reduce the risk of electric shock. This tool is equipped with an electric cord having an equipment-grounding conductor and a grounding plug. The plug must be plugged into a matching outlet that is properly installed and grounded in accordance with all local codes and ordinances.

Do not modify the plug provided. If it will not fit the outlet, have the proper outlet installed by a qualified electrician.

Improper connection of the equipment-grounding conductor can result in a risk of electric shock. The conductor, with insulation having an outer surface that is green with or without yellow stripes, is the equipment-grounding conductor. If repair or replacement of the electric cord or plug is necessary, do not connect the equipment-grounding conductor to a live terminal.

Check with a qualified electrician or service personnel if the grounding instructions are not completely understood, or if in doubt as to whether the tool is properly grounded.

Use only three wire extension cords that have three-prong grounding plugs and three-pole receptacles that accept the tool's plug.*

Repair or replace a damaged or worn cord immediately.

This tool is intended for use on a circuit that has an outlet that looks the one illustrated in Figure A below. The tool has a grounding plug that looks like the grounding plug as illustrated in Figure A below.

* Canadian electrical codes require extension cords to be certified SJT type or better.

** Use of an adapter in Canada is not acceptable.

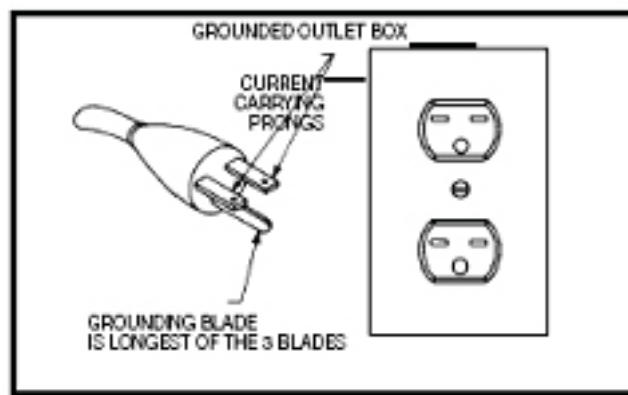
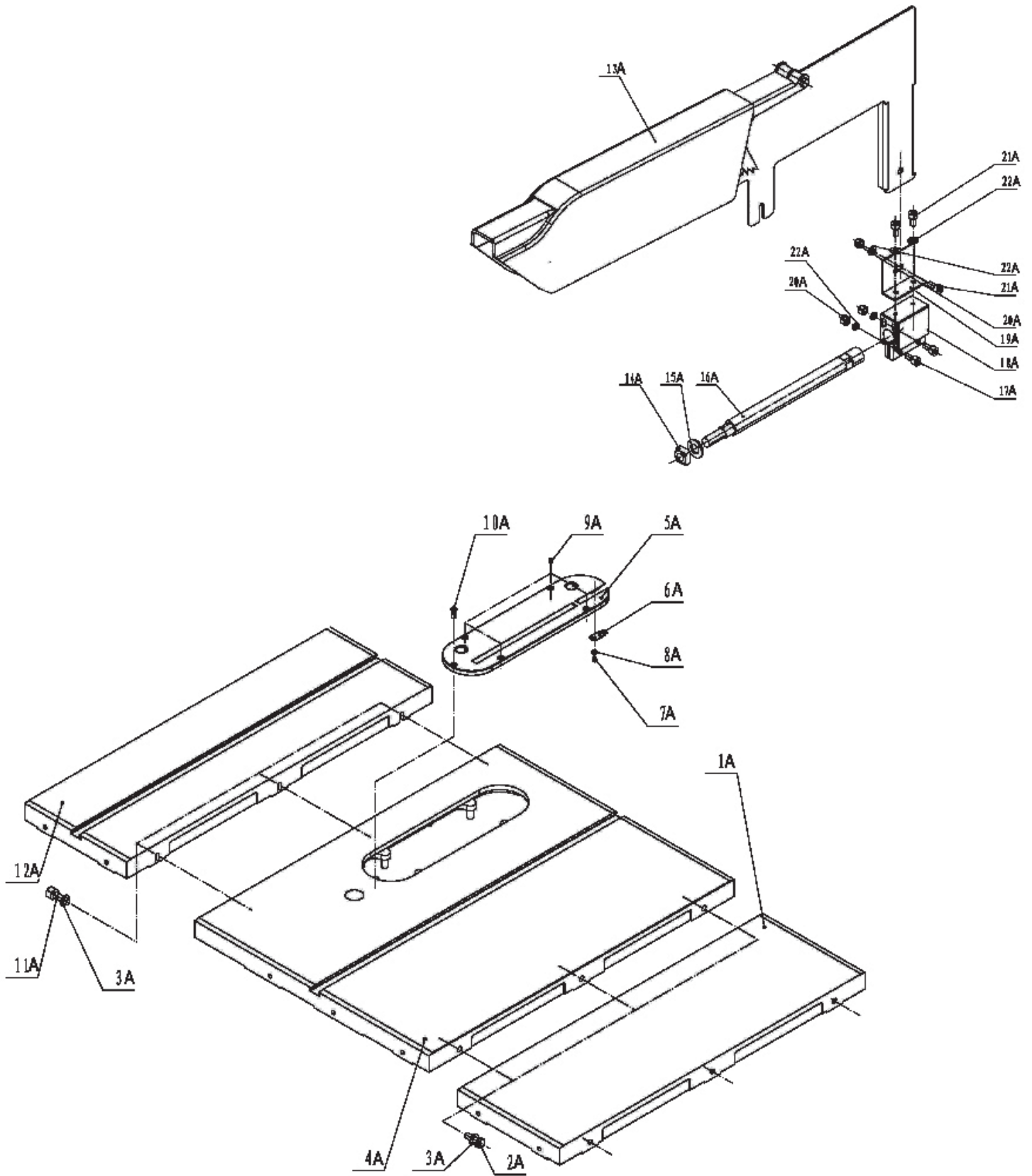
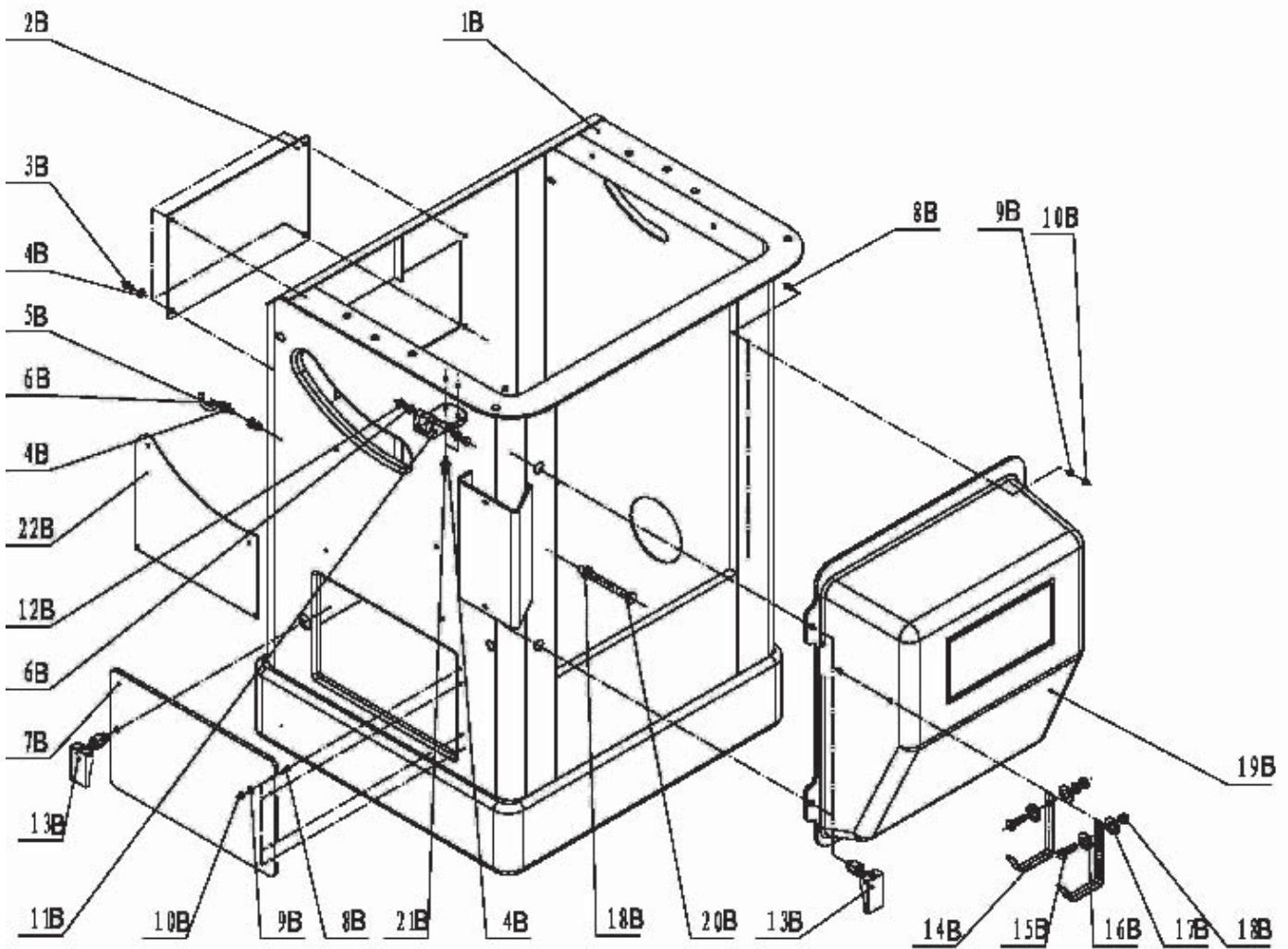

Figure A

Parts Diagram



Parts Diagram



Parts List

Key Part No.	Description	Key Part No.	Description		
1A	1-JL84010002	Extension wing	1B	1-JL84021000	Cabinet
2A	1-M10X30GB5783Z	Hex bolt M10X30	2B	1-JL84020002	Cover plate
3A	1-WSH10GB95Z	Washer 10	3B	1-M6X10GB818Z	Set screw M6X10
4A	1-JL84010001	Table	4B	1-WSH6GB95Z	Washer 6
5A	1-JL84010003	Table insert	5B	1-JL84020003	Hook
6A	1-JL84010005	Spring plate	6B	1-M6GB6170Z	Nut M6
7A	1-M4X6GB818Z	Set screw M4X6	7B	1-JL84020006	Cover plate II
8A	1-WSH4GB95Z	Washer 4	8B	1-M5X10GB819Z	Screw M5X10
9A	1-M6X8GB77B	Set screw M6X8	9B	1-WSH7GB97D1Z	Washer 7
10A	1-M6X16GB819B	Set screw M6X16	10B	1-M5GB923Z	Nut M5
11A	1-M10X30GB70Z	Hex bolt M10X30	11B	1-JL84020001	Micro-adjusting bracket
12A	1-JL84010002A	Extension wing II	12B	1-M6X25GB5783Z	Hex bolt M6X25
13A	1-JL84091000	Guard	13B	1-JL91042100	Locking bar assembly
14A	1-M10GB39Z	Square nut M10	14B	1-JL84020004	Support bracket
15A	1-WSH10GB95Z	Washer 10	15B	1-M8X16GB5781Z	Hex bolt M8X16
16A	1-JL84090001	Shaft	16B	1-WSH8GB95Z	Washer 8
17A	1-M5X20GB70Z	Set screw M5X20	17B	1-WSH8GB93Z	Washer 8
18A	1-JL84090002	Lower blade guard bracket	18B	1-M8GB6170Z	Nut M8
19A	1-JL84090003	Upper blade guard bracket	19B	1-JL84022000	Motor cover
20A	1-M5GB6170Z	Nut M5	20B	1-M8X65GB5781Z	Hex bolt M8X65
21A	1-M5X10GB70Z	Bolt M5X10	21B	1-M6X20GB5783Z	Hex bolt M6X20
22A	1-WSH5GB97D1Z	Washer 5	22B	1-JL84120001	RIKON label

Parts Diagram

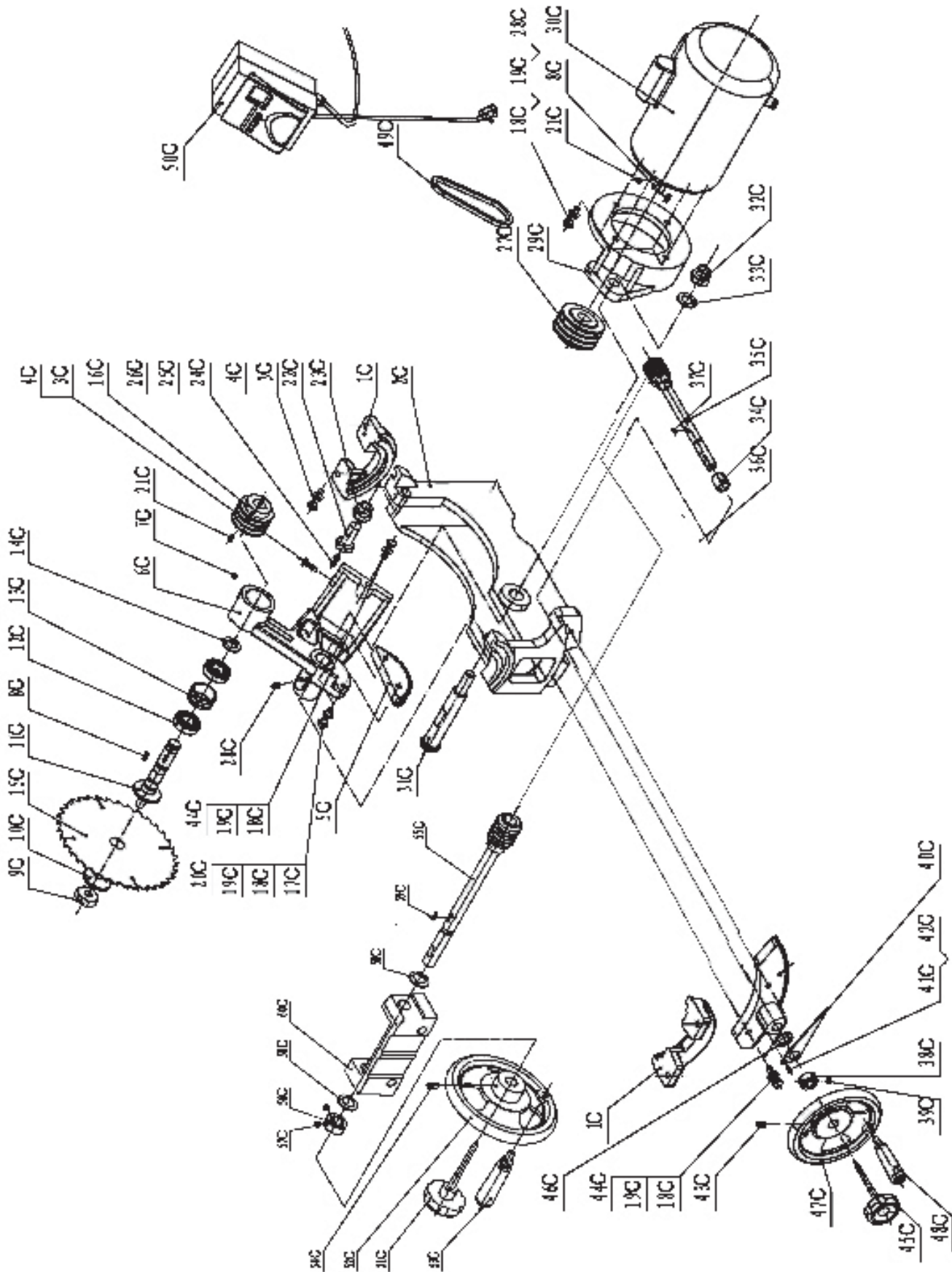

Parts List

Key Part No.	Description	Key Part No.	Description		
1C	1-JL84040002	Trunnion bracket	31C	1-JL84040003	Shaft
2C	1-JL84040001	Trunnion	32C	1-M20GB889D1Z	Locking nut M20
3C	1-M8X25GB5783Z	Hex bolt M8X25	33C	1-WSH20GB95Z	Washer 20
4C	1-M8GB6170Z	Nut M8	34C	1-JL84040005	Collar
5C	1-JL84042003	Turbine	35C	1-JL84041000	Worm shaft assembly
6C	1-JL84042001	Arbor bracket	36C	1-JL84040004	Turbine II
7C	1-M10X10GB77B	Set screw M10X10	37C	1-PIN5X19GB1099	Pin 5X19
8C	1-PIN6X32GB1096	Pin 6X32	38C	1-JL84030002	Collar
9C	1-JL84042102	Arbor nut	39C	1-M8X8GB77Z	Set screw M8X8
10C	1-JL84042103	Arbor flange	40C	1-JL84040006	Pointer
11C	1-JL84042101	Arbor with flange	41C	1-M4X8GB818Z	Screw M4X8
12C	1-BRG6205GB276	Ball bearing	42C	1-WSH4GB95Z	Washer 4
13C	1-JL84042104	Bearing load spacer	43C	1-M8X16GB80B	Set screw M8X16
14C	1-CLP25GB894D1	Retaining ring	44C	1-M10X35GB5783Z	Hex bolt M10X35
15C	1-JL84042004	Blade	45C	1-JL84030003	Lock knob
16C	1-JL84042002	Arbor pulley	46C	1-JL50000005	Washer plate
17C	1-M10X40GB5781Z	Hex bolt M10X40	47C	1-JL84032000(1)	Handwheel
18C	1-WSH10GB95Z	Washer 10	48C	1-JL84032000(2)	Hand wheel handle
19C	1-WSH10GB93Z	Washer 10	49C	1-JL84040007	V-belt
20C	1-M10X50GB5781Z	Hex bolt M10X50	50C	1-HNPB-18K	Magnetic switch
21C	1-M8X12GB77B	Set screw M8X12	51C	1-JL84030003	Lock knob
22C	1-JL84043001	Adjusting bolt for guard	52C	1-JL84032000(1)	Handwheel
23C	1-JL84043002	Adjusting nut for guard	53C	1-JL84032000(2)	Hand wheel handle
24C	1-WSH6GB96Z	Washer 6	54C	1-M8X16GB80B	Set screw M8X16
25C	1-WSH6GB93Z	Spring washer 6	55C	1-JL84031000	Worm shaft assembly II
26C	1-M6X10GB70D1Z	Screw M6X10	56C	1-JL84030002	Collar
27C	1-JL84044001	Motor pulley	57C	1-M8X8GB77Z	Set screw M8X8
28C	1-M10X30GB5783Z	Hex bolt M10X30	58C	1-JL50000005	Washer plate
29C	1-JL84044003	Motor mounting bracket	59C	1-PIN5X19GB1099	Pin 5X19
30C	1-G1123692	Motor	60C	1-JL84030001	Support bracket

Parts Diagram

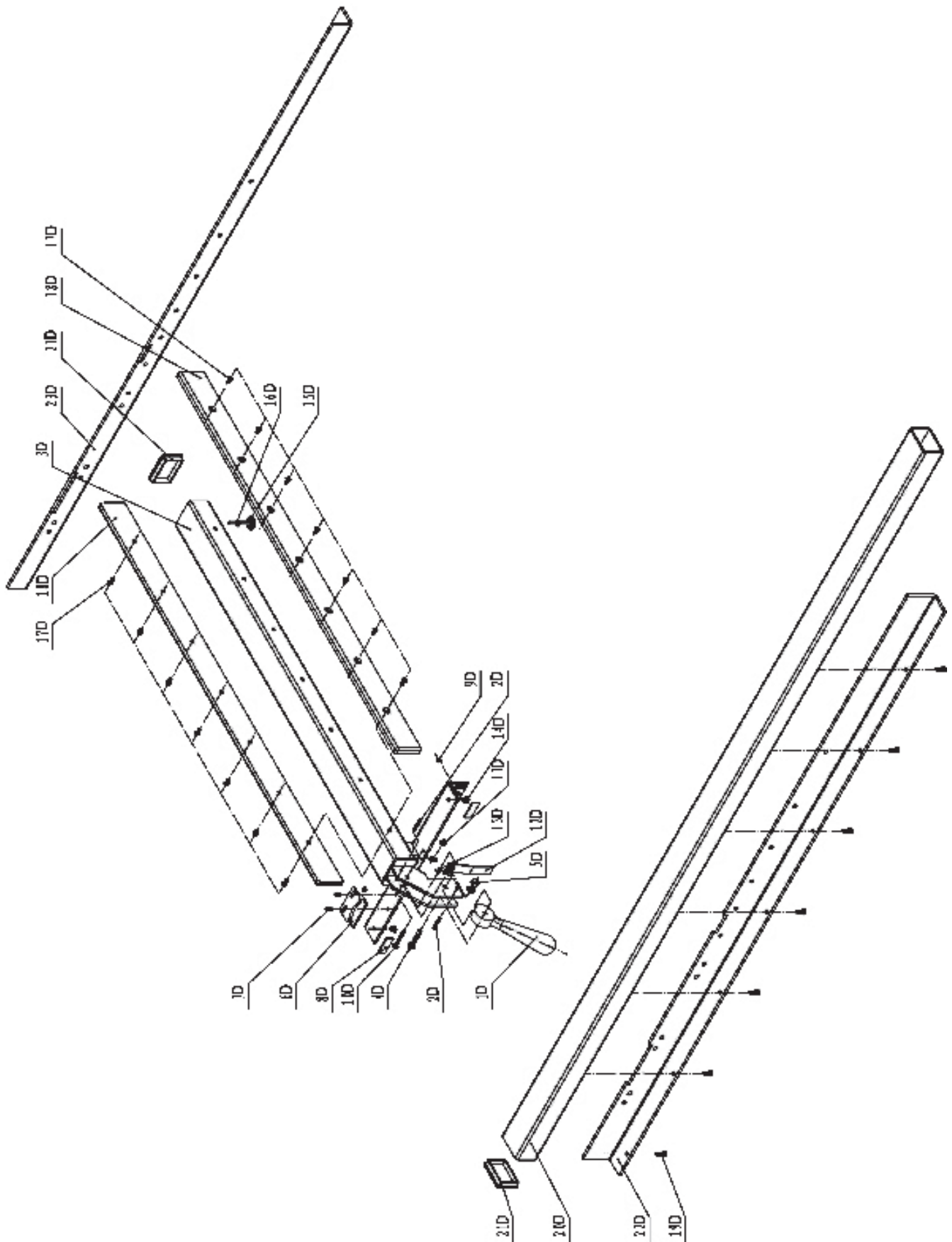

Parts List

Key Part No.	Description
1D 1-JL84051200	Lock handle assembly
2D 1-PIN5X30GB879B	Pin 5X30
3D 1-JL84051100	Fence bracket assembly
4D 1-M8X45GB12Z	Carriage bolt M8X45
5D 1-M8GB889Z	Nut M8
6D 1-JL84051003	Magnifier
7D 1-M5X8GB818Z	Screw M5X8
8D 1-JL84051008	Frication plate
9D 1-M8X8GB77B	Screw M8X8
10D 1-M6X40GB5783Z	Hex bolt M6X40
11D 1-M6GB889Z	Locking nut M6
12D 1-JL84051001	Bracket
13D 1-JL84051004	Torsion spring
14D 1-JL84051005	Adjusting screw
15D 1-JL84051007	Rear support bracket
16D 1-M6GB6170Z	Nut M6
17D 1-M6X16GB818Z	Pan head screw M6X16
18D 1-JL84051002	Defend plate
19D 1-M6X12GB5783Z	Hex bolt M6X12
20D 1-JL84050002	Front fence rail
21D 1-JL84051006	Tube cap
22D 1-JL84050001	Front fence rail support
23D 1-JL84050003	Rear fence support

RIKON **POWER TOOLS**

2-Year Limited Warranty

RIKON Power Tools/Richen Enterprise, Inc. (“Seller”) warrants to only the original retail consumer/purchaser of our products that each product be free from defects in materials and workmanship for a period of two (2) years from the date the product was purchased at retail. This warranty may not be transferred.

This warranty does not apply to defects due directly or indirectly to misuse, abuse, negligence, accidents, repairs, alterations, lack of maintenance or normal wear and tear. Under no circumstances will Seller be liable for incidental or consequential damages resulting from defective products. All other warranties, expressed or implied, whether of merchantability, fitness for purpose, or otherwise are expressly disclaimed by Seller. This warranty does not cover products used for commercial, industrial or educational purposes.

This limited warranty does not apply to accessory items such as blades, drill bits, sanding discs or belts and other related items.

Seller shall in no event be liable for death, injuries to persons or property, or for incidental, contingent, special, or consequential damages arising from the use of our products.

To take advantage of this warranty proof of purchase documentation, which includes date of purchase and an explanation of the complaint, must be provided.

The Seller reserves the right to effect at any time, without prior notice, those alterations to parts, fittings, and accessory equipment which they may deem necessary for any reason whatsoever.

To take advantage of this warranty, please fill out the enclosed warranty card and send it to:
RIKON Warranty
110 Cummings Park
Woburn, MA 01801

The card must be entirely completed in order for it to be valid. If you have any questions please contact us at 877-884-5167 or warranty@rikontools.com.

RIKON **POWER TOOLS**

**For more information:
110 Cummings Park
Woburn, MA 01801**

**877-884-5167/781-933-8400
techsupport@rikontools.com
www.rikontools.com**