

# 10" Meat Cutting Bandsaw

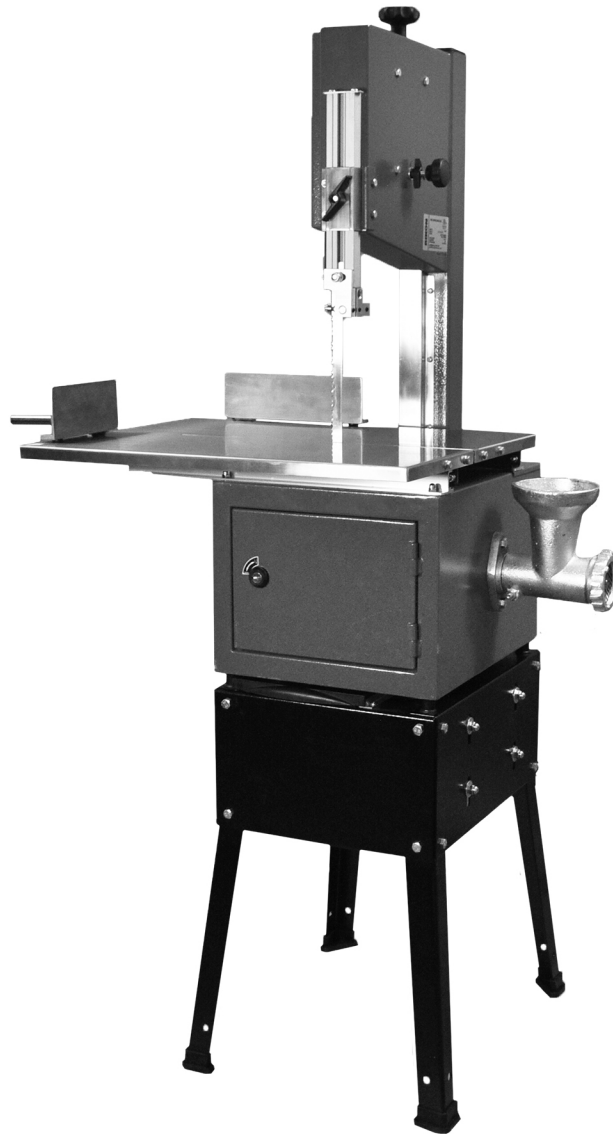

## Operator's Manual

Record the serial number and date of purchase in your manual for future reference.

Serial number: \_\_\_\_\_ Date of purchase: \_\_\_\_\_

For technical support of parts questions, email [techsupport@rikontools.com](mailto:techsupport@rikontools.com) or call toll free at (877)884-5167

# Table of Contents

Thank you for your tool purchase. When properly assembled, wired, operated and maintained your RIKON product will give you years of dependable service. Please read and understand the owner's manual completely.

Specifications.....	2
Safety Instructions.....	3 - 5, 8, 14
Package Contents.....	6
Saw Features.....	7
Electrical.....	8
Assembly.....	9, 10
Adjustments.....	11 - 13
Blade Changing, Tension & Tracking.....	11, 12
Blade Guide Adjustments.....	13
Saw Operation.....	14
Grinder Operation & Cleaning.....	14
Parts Breakdown.....	15 - 17
Parts List.....	17, 18
Warranty.....	19

## Specifications

Model:	10-308
Type	Floor Model
Motor/Phase	1ph TEFC
Voltage/Amps	115V / 5A
Horse Power	3/4 HP
Cutting Height	8-1/2"
Cutting Width	9-1/4"
Blade Length	76-3/4" Stainless
Blade Width	5/8"
Blade Speed	950 FPM
Sliding Table Stroke	8"
Max Cut	8"
Fence Adj	8"
Sausage Grinder Speed	300 RPM
Die Dia	2-1/2"
Height	57-1/2"
Width	21"
Table Dimensions	22" x 17"
Net Weight	150 LBS
Shipping Weight	170 LBS
Carton Size	17" x 19" x 39"

# General Safety Guidelines

**IMPORTANT — REQUIRED READING!** Safety is the single most important consideration in the operation of this equipment. The following safety instructions must be adhered to at all times.

## ⚠ WARNING



Failure to read and understand this manual before you unpack, assemble, wire, operate and maintain this machine may result in serious injury to yourself or others. Review and understand all safety procedures and requirements. If you do not understand any content of this manual including how to assemble, wire, operate and maintain this machine safely, do not use this machine.

Using power tools or equipment of any kind can be dangerous if safe operating procedures are not followed. Recognizing the hazards of each tool and using them with respect and caution will considerably limit the possibility of personal injury. However, if safety precautions are ignored, personal injury will likely result. Always use common sense. Your personal safety is your responsibility.

No manual can list every safety precaution or operating procedure as it pertains to a given work area and environment. Use good judgment, think and apply safety measures before taking any action. Failure to do so may result in serious injury, damage to equipment and surroundings and/or give negative performance results.

There are certain applications for which this tool was designed. We strongly recommend that this tool not be modified and/or used for any other application other than for which it was designed. If you have any questions about its application, do not use the tool until you have contacted us and we have advised you.

## General Safety Rules & Hazards



**Do not operate** equipment while tired or under the influence of drugs, alcohol or medication that causes physical or mental impairment. Full physical and mental alertness is required to operate power tools.

**Do not operate** this machine until it is completely assembled. Incomplete or incorrect assembly can cause serious injury.

**Use the right tool** for the job. Do not force a tool to do something it was not designed for.

**Do not make** any changes or modifications to any power tool or machinery. This may cause personal injury and even death.



**Wrenches & chuck keys:** Remove any wrenches, chuck keys or other tools and items from the machine before starting the machine as they can fly and strike the operators and others in the shop area.



**Guards:** Make sure all guards are in place and working correctly before operating the machinery.

**Secure work:** Use proper hold downs, clamps, and vises to secure work before machining. It will give you safer control of the work piece and better results.

**Accessories:** Use only recommended accessories with machinery. Home made jigs, fixtures and clamps may be dangerous and cause serious injury.

**Maintain machinery** in top working condition. This includes keeping tools clean and sharp. A well cared for machine will be inherently safer, provide longer service and give optimum results.

**Replace damaged parts** and thoroughly inspect machinery before each use. Any loose, broken or mis-

# General Safety Guidelines

aligned parts or guards need to be fixed before operation. Check for alignment or binding of moving parts and any other condition that may effect its proper operation. Always disconnect the machine from the power source before inspecting or repairing it.

**Do not over-exert yourself.** Tools can be heavy. Get assistance to lift and position tools and machinery. Improper lifting and moving beyond your capabilities may cause serious injury.

**Do not use** power tool as a bench, stool, ladder or support. Do not stand on the tool.



**Hands and Feet** should be kept away from cutters, moving parts and assemblies at all times.



**Do not over-reach.** Keep secure footing and balance at all times. Failure to do so may cause contact with moving parts causing serious injury.



**Always Use** appropriate hearing protection while using any power tool.



**Long hair** should be tied back or kept in a protective hair covering in a way that it does not get caught in machinery.



**Clothing:** No loose clothing, rings, neckties, jewelry, bracelets, and gloves should be worn. These items and others may get caught in equipment and cause serious injury. Non-slip footwear is recommended, along with protective hair covering for longer hair.

**Risk of breathing:** Use an approved dust mask and air filtration system. Keep area clean, dust off motor and use a dust collector.



**Airborne Dust:** Some dust created by power tool use is known to cause cancer, birth defects or other reproductive harm. To minimize your risk work in a well ventilated area and always wear personal protective equipment such as dust masks and respirators designed to filter out microscopic particles. Lead from lead based paint, crystalline silica from bricks and cement, and arsenic chromium from chemically treated lumber are just some examples.



**California proposition 65:** Some dust created by sanding, sawing, grinding, drilling and other activities contains chemicals known to cause cancer, birth defects or other reproductive harm.

Risk is dependent upon the amount of exposure and how often you do this kind of work. To reduce exposure always work in a well ventilated area using a dust collector and wear approved safety equipment. Always wear NIOSH/OSHA approved and properly fitted face mask or respirator. For more information logon to [www.rikontools.com](http://www.rikontools.com).

**Work area:** K ork in a well lit area, do not operate in dark, damp or wet locations or where any noxious or flammable fumes may be present.



**Operators:** Keep children, visitors and untrained operators away from equipment while in use. Do not get distracted by others when operating power tools.

**Childproof the power tool.** Use lock-out switches on machinery or use master switches or remove starter keys so machines cannot be turn on by children. Make sure power tools cannot be started accidentally.

**Never** leave machine running unattended. Disconnect machine from power source when not in use or when performing any maintenance. Don't leave tool until it has come to a complete stop.



**Ground all tools.** If your tool is equipped with a 3 prong plug, you must plug it into a 3 prong electrical receptacle. If you use an adaptor to accommodate a 2 prong receptacle, you must connect the adaptor plug to a known ground. Never cut grounding pin from a 3-prong plug.

**Never** use the bandsaw with an ungrounded electrical connection/outlet. Connect to a properly grounded outlet with proper voltage and fuse protection. Improper grounding can result in electrical shock.



# Safety Guidelines

**Follow** all electrical and wiring codes in your area to prevent shock or electrocution.

**Accidental Starting:** Make sure the switch is in the “OFF” position before plugging in power cord.

**Magnetic switches** or starter switches may start unintentionally if accidentally bumped. Disconnect machine from power source when changing blades (tooling), making adjustments or servicing the machine.

**Do not expose** the meat bandsaw to rain/water or operate in a wet area; an electrical hazard may be created.

**Risk of electrical shock:** Disconnect bandsaw from electrical power source before servicing or performing maintenance.

**Extension cords;** Do not use under-sized extension cords. Use only properly sized & approved grounded extension cords. Do not use extension cords on 220V machinery. Use chart as a reference for minimum gage extension cords. Run only one machine per extension cord. Replace worn or damaged extension cords.

**Kickback:** Be aware of “kickback” and how to avoid it. Binding, misalignment, improper settings and adjustment of machinery especially woodworking tools may cause kick-back and serious injury.

## Meat Saw Safety

**Improper operation** or maintenance of this product could result in serious injury and property damage. If you are unfamiliar on how to operate this machine get assistance or advice from a person who is familiar with the safe assembly, installation and operation of this machine.

**Do not operate this machine** on an unstable surface. Operating the saw on bare ground or uneven surface can cause a serious injury. Make sure work surface is stable.

**Support** the meat firmly with the fence, backstop, or worktable when cutting and avoid awkward operations and hand positioning. For long or heavy pieces support the piece using an auxiliary support.

**Do not** cut very small or very thin pieces that are difficult to control. This can create an unsafe condition.

**Risk from moving parts:** Never touch moving parts. Maintain a clearance of 1” between the blade and fingers. Always cut on the downward side, or movement, of the bandsaw blade.

**Always use the** stuffing tool when grinding. **Never** try to push meat in the grinder by hand.

**Prevent** the meat from contacting the blade before starting the machine.

**Keep area clean for** food processing. It is important to keep the work area and machine sanitary and clean in order to process food safely. Consult your Board of Health or USDA regulations for information.

**Do not** hose down, spray or soak the bandsaw with water or cleaners while it is plugged in or connected to an electrical source. Even when unplugged the switch, motor and other electrical components must not get wet. Failure to do so may cause serious injury.

### **Shut down procedures:**

Turn the machine “off” using the switch.

Disconnect machine from power source.

Clean work area, benches, tables, floor and any container.

Use the “lockout” on switch to prevent children and unauthorized personnel from accidentally starting bandsaw.

**Cleaning:** Wear approved safety equipment, eye, ear, respiratory and clothing protection when cleaning your meat saw.

**Compressed air:** When using compressed air do not exceed 30 lbs PSI air pressure.

**Never** clean plastic parts with any kind of solvent as it can damage parts.

**Always** clean and work in a well ventilated area.

**Use only** approved cleaners for meat processing and food preparation to disinfect the bandsaw for meat processing. Do not use industrial solvents as they can contaminate the meat and make people sick.

**Small parts** may be washed in a dishwasher.

## Package Contents

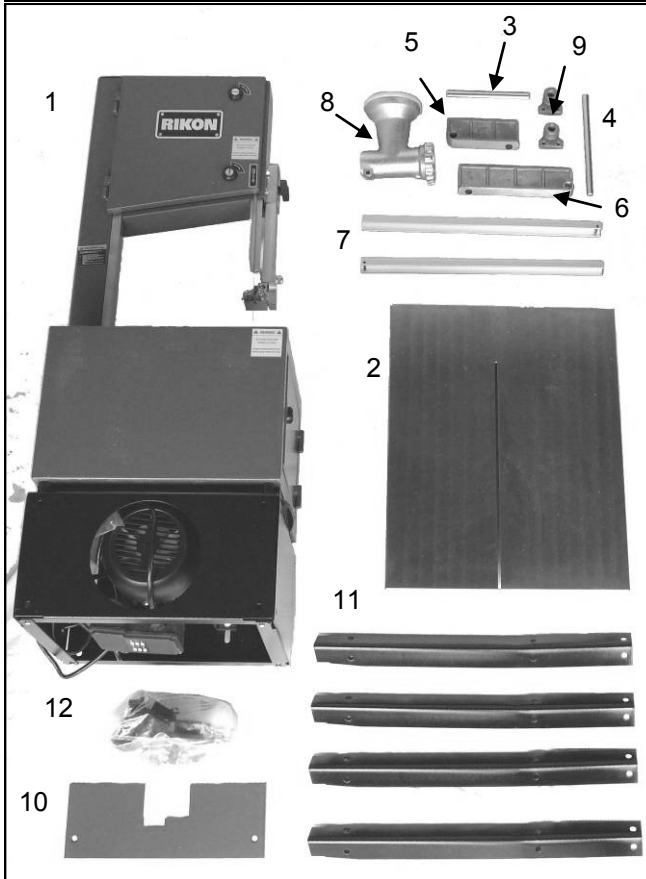

If you suspect freight damage please save all packing materials for inspection and contact your RIKON dealer where you purchased your saw.

The meat bandsaw is heavy. Be careful when lifting and moving the carton prior to assembly. Get help if necessary.

Unpack the contents and take inventory of what you have.

1. Main Unit
2. Sliding Table
3. Rod a
4. Rod b
5. Fence a
6. Fence b
7. Slides (front & rear)
8. Grinder
9. Rod Holders (2)
10. Cover Plate
11. Legs (4)
12. Hardware & Components
  - a. Rubber Feet (4)
  - b. Funnel
  - c. Grinder Stuffer
  - d. Table Brace (on table)
  - e. Locking Knobs (2)
  - f. Carriage Bolts & Acorn Nuts for Slides (4)
  - g. Bolt & Nut for Grinder
  - h. Set Screws (2)
  - i. Cap Screws for Stops (2)
  - j. Bolts for Rod Holders (4)
  - k. Blade Tension Knob
  - l. Bolt & Nuts for Legs (16)
  - m. 10mm Wrench
  - n. 13mm Wrench
  - o. 3mm Allen Wrench
  - p. 4mm Allen Wrench
  - q. 5mm Allen Wrench



Tools Needed: #2 Phillips Screwdriver

Should you have some components or hardware missing, please contact the RIKON dealer where you purchased your bandsaw. In the rare instances were there are just some washers or nuts missing, it might save time just to grab some at the local hardware store. In any case we will be glad to help you.

# Identifying Features

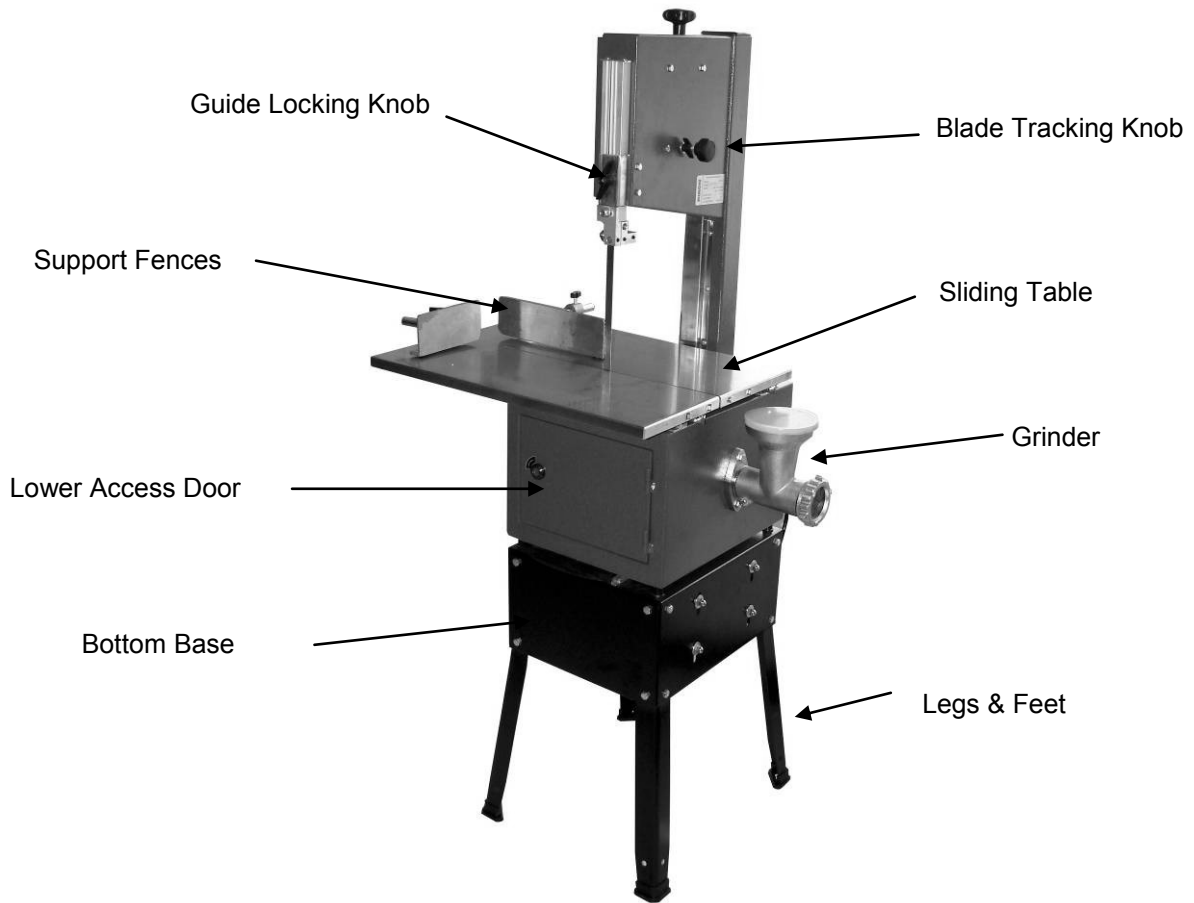
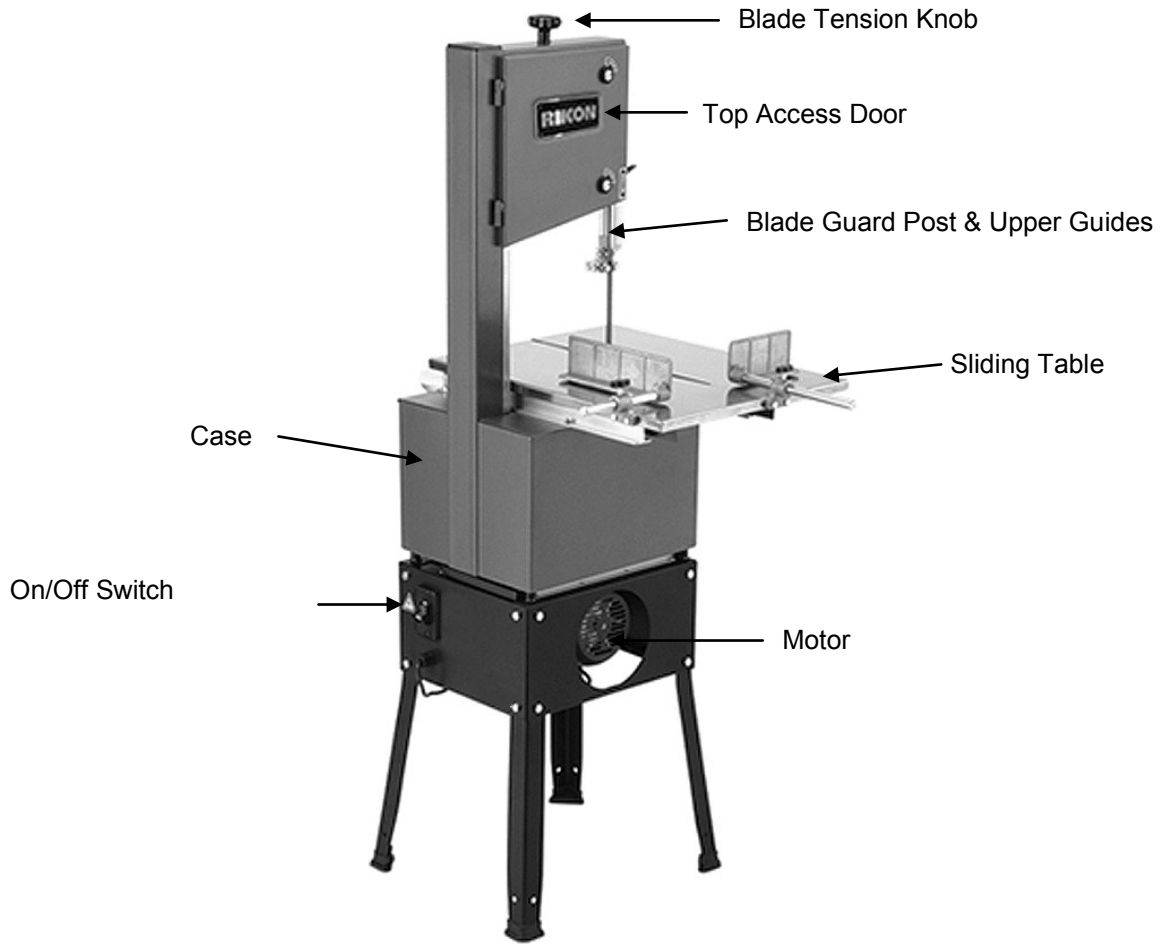

Motor Connection

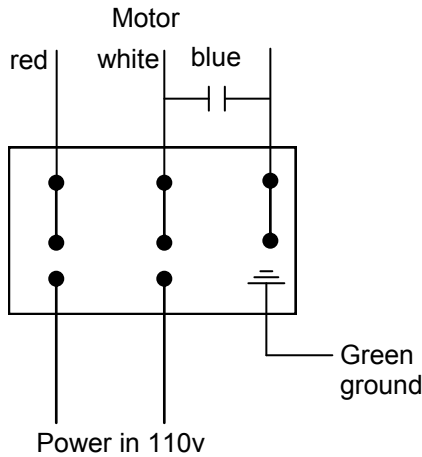

Extension Cords for 120 Volts

Amp Rating	Length	Minimum Wire Gauge
6A	<25ft	18 AWG
	25ft-50ft	16 AWG
	50ft-100ft	16 AWG
	100ft-150ft	14 AWG
6A-10A	<25ft	18 AWG
	25ft-50ft	16 AWG
	50ft-100ft	14 AWG
	100ft-150ft	12 AWG
10A-12A	<25ft	16 AWG
	25ft-50ft	16 AWG
	50ft-100ft	14 AWG
	100ft-150ft	12 AWG
12A-16A	<25ft	14 AWG
	25ft-50ft	12 AWG
	Extensions cords longer than are 50ft not recommended	

Use this table as a guideline only. You must follow all electrical codes and safety procedures for your area in the use of extension cords.

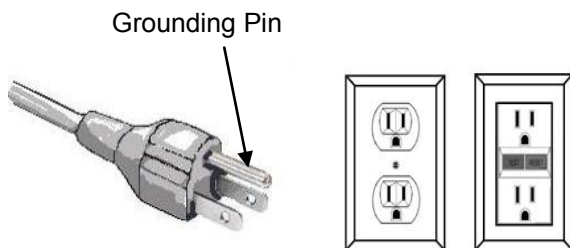

## Electrical

This bandsaw is designed to operate on 110v. It is your responsibility to ensure that the bandsaw is electrically connected in a safe and correct manner. Any electrical work should be performed by a competent electrician and installed in a way that meets all applicable electrical codes and regulations.

A dedicated electrical circuit should be used and wiring must be able to carry full voltage  $\pm 10\%$  to the bandsaw. The recommended circuit should be applicable for a 3/4hp 5A motor with a fuse or circuit breaker and wired accordingly.

This saw is supplied with a safety on/off key switch. The key can be removed to "lock out" unauthorized personnel like children from accidentally starting the bandsaw. Please make use of this feature.

## Grounding Instructions

This unit must operate using a completely grounded electrical line. The plug must be plugged into an outlet that is properly installed and grounded according to all electrical codes. If you do not know if the electrical circuit is grounded, contact an authorized and qualified electrician and have it inspected/replaced.

This product uses a 110v cord with a 3 prong plug. Make sure that the product is connected to an outlet having the same configuration as the plug. No adapter should be used to operate this bandsaw.

## Extension Cords

The use of any extension cord will cause some drop in voltage and loss of power. For optimum performance plug the power cord directly into a grounded outlet of the proper voltage and amp rating. If the use of an extension cord cannot be avoided make sure the cord is in good condition and has a ground wire. The gauge should be sufficient to carry the voltage and amp load at the distance required. The smaller the gauge number the heavier the cord. Only use extension cords with a 3rd wire grounding pin that match the corresponding 3-conductor receptacle.

## ⚠ WARNING

**Never** cut the grounding pin off a plug. If the plug does not fit, **do not** cut the end or modify the electrical outlet. Shown left is a standard 3 prong 110v electrical receptacle and GFI receptacle.

**Do not** wash, clean, sanitize or operate the bandsaw in wet conditions while it is plugged in at any time.

Incorrectly wired buildings or buildings with poor electrical service can result in premature motor failure and is not covered by the warranty. Failure to connect the bandsaw correctly to the electrical service may result in serious personal injury, damage to the bandsaw and/or building site.

Overloaded circuits are dangerous and can present an electrical and/or fire hazard causing serious injury.

## Leg Assembly

To assemble the legs proceed as follows.

- Set the main saw body on its side.
- Gather up the following parts:
  - a. Legs (4)
  - b. Hex Head Bolts (16)
  - c. Hex Nuts (16)
  - d. Rubber feet (4)
- Slide the legs in the bottom slots and align holes.
- Attach 2 legs using the bolts and hex nuts provided by lining up the leg holes with the holes in the lower saw body.
- Roll the saw over, attach the other 2 legs and 4 rubber feet.
- With help lift and tilt the bandsaw to its upright position.

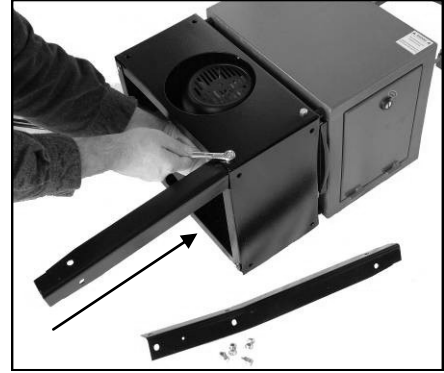

## Table Assembly

- To attach the sliding table you need to gather up:
  - a. Sliding Table
  - b. Cover Plate
  - c. Front Slide
  - d. Rear Slide
  - e. Cap Screws (2)
  - f. Carriage Bolts (4)
  - g. Acorn nuts (4)
- Align the Plate Cover with the holes to the top of the saw base by the column.
- On top of the Plate Cover align the Rear Slide (A) to the same holes.
- Notice the rails extend over the front of the saw in the operating position.
- Secure both the Plate Cover and Rear Slide using the carriage bolts and acorn nuts. Run the carriage bolts up from underneath the saw body with the acorn nuts on top.
- Attach the Front Slide (B) using the carriage bolts and acorn nuts provided.
- You will have to remove the 4 hex bolts and table alignment brace to slide the table past the blade.
- Place the Sliding Table onto the rails so the bearings can slide back and forth smoothly. You might have to adjust the slides a little for smooth travel. Slide the table as far forward as it will go without allowing it fall off.
- Re-attach the table alignment brace you took off to the back end of the sliding table using the 4 hex head bolts and flat washers provided.
- The 2 cap screws are used as stops for the table. First screw on 2 hex nuts to each cap screw.
- Position the cap screws onto the underside of the table as shown and affix using 2 more hex nuts.
- Adjust nuts on cap screw so table stops.

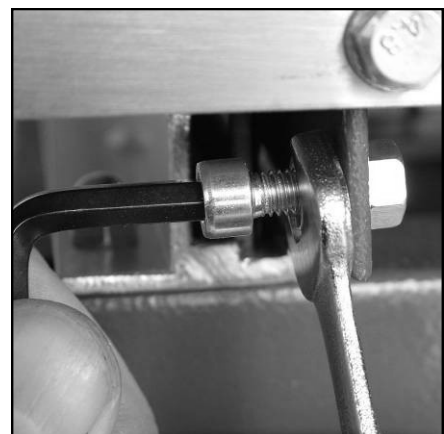
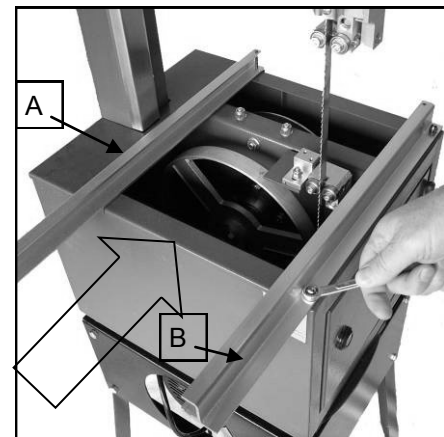
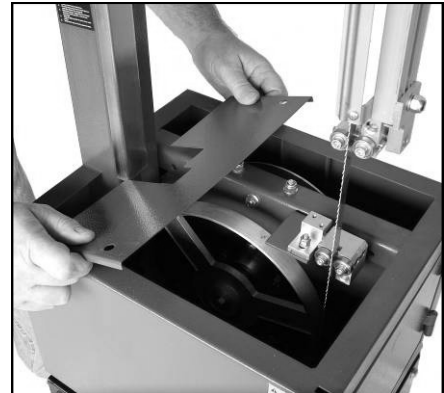

## Assembly

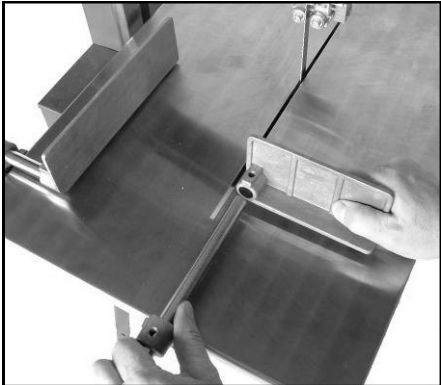
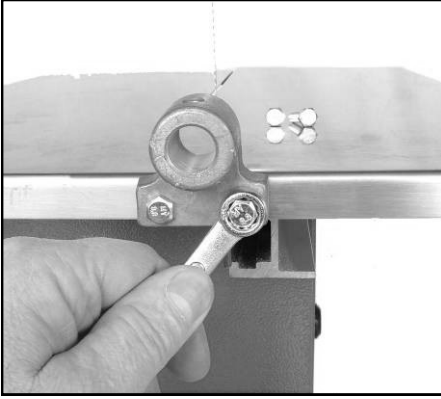

### Fence Assembly

There are 2 fences to support the meat and adjust for slice thickness.

- Gather up the following parts and components
  - a. Rod Holders (2)
  - b. Lock Knobs (2)
  - c. Long Rod (1)
  - d. Short Rod (1)
  - e. Short Fence (1)
  - f. Long Fence (1)
  - g. Hex Head Bolts (4)
  - h. Set Screws (2)
- Mount the 2 rail holders to the front and left side of the sliding table using the hex bolts provided.
- Insert the longer rod into the longer fence and attach with the set screw.
- Insert the shorter rod into the shorter fence and attach with set screw
- Slide the longer fence into the rod holder on the left side of the sliding table and tighten with the locking knob provided.
- Slide the shorter fence into the rod holder on the front of the sliding table and tighten using the locking knob provided.
- You can use the locking knobs to adjust the location of the fences.
- You can also swap the rods and fences around for better sizing.

### Meat Grinder Assembly

The internal parts of the meat/sausage grinder are shown at left. **CAUTION!** Make sure you do not attach the grinder to the saw unless you are ready to grind meat. Meat acts as a lubricant so operating the grinder dry will damage it.

\*\* Attach the grinder's Bracket (part #66) to the rear panel of the saw with the 2 Hex Bolts and Flange Nuts (#78). The motor's Drive Shaft (#73) will go through the bracket.

- Gather up the following components and parts.
  - a. Meat Grinder
  - b. Hex Bolt (1)
  - c. Hex Nut (1)
- At the bottom of saw base is where the flat drive for the grinder comes out. The grinder end has a mating slot for connecting the grinder to the saw, which in turn drives the worm drive.
- Looking at the end of the grinder there is a corresponding slot that needs to be lined up with the flat point inside the grinder holder. Rotate to line up if necessary.
- Slide the female end of the grinder over the male end grinder holder making sure the slot is lined up and secure using the hex bolt and nut provided.
- Make sure the grinder will turn and run smoothly.
- Remember do not operate the grinder dry.

# Adjustments

## Blade Changes

Over time blades can become dull and need to be changed.

To change the blade you need to remove the sliding table, the sliding rail next to the column and the corresponding cover plate underneath.

- Move the upper guide post up from the sliding table.
- Unscrew the 4 bolts that hold the table bracket on to sliding table and remove.
- Remove the 2 cap screws that are used as table stops from the sliding table.
- Carefully slide the table off the unit past the band-saw blade and set aside.
- Remove the rear slide (one closest to column) and the cover plate.
- Adjust lower bearing guides away from bandsaw blade.
- Remove blade guard on column.
- Remove the blade guard which is attached to the guide post.
- Take the tension out of the blade by loosening the tension knob.
- Remove the blade from the upper and lower wheels.

## Blade Installation

To install a new blade reverse the above procedures making sure the new bandsaw blade tracks true and all components removed are adjusted properly and are back in their proper place or setting. Please follow bandsaw blade tensioning and tracking procedures.

### **⚠ WARNING**

Bandsaw blades are sharp take care in the installation and removal process. Wear protective gloves if necessary

Make sure the bandsaw is disconnected from the power source before making any adjustments.

Guide Lock Knob

Upper Guide

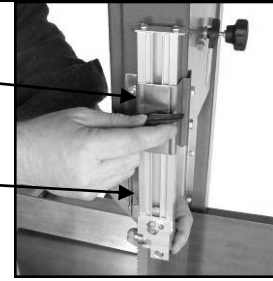
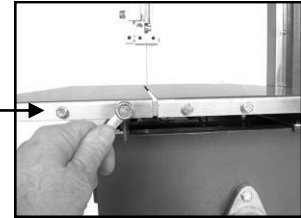
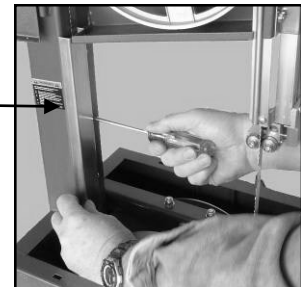

Table bracket



Blade Guard



Blade guard

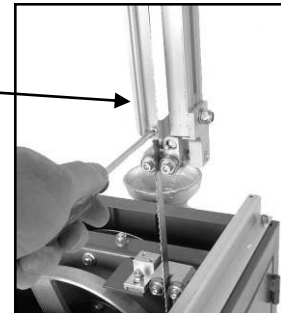

Parts removed to change blade

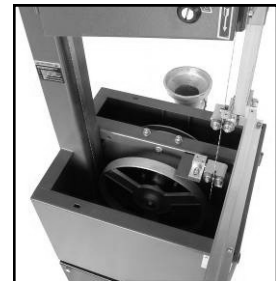

Changing Blade

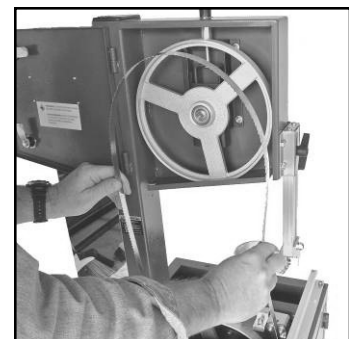

## Adjustments



Tacking Adjustment Lock Knob

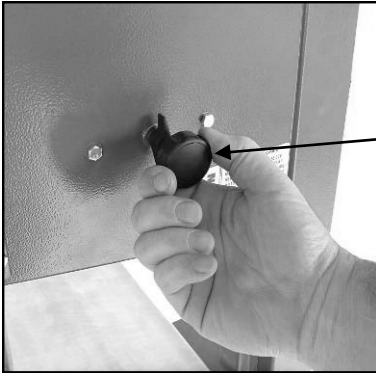

Tacking Adjustment Knob

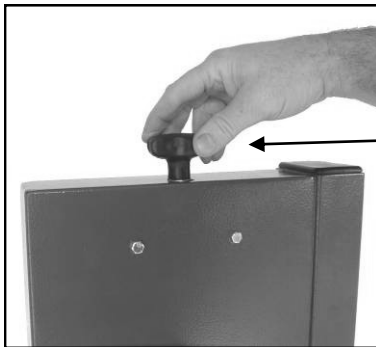

Blade Tensioning Knob

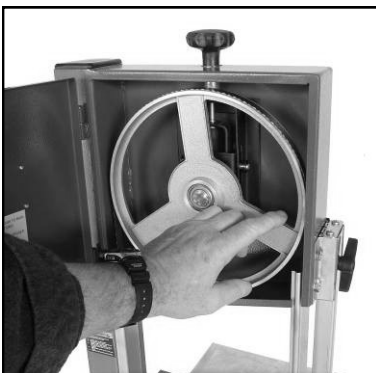

Turning wheel to check blade tracking



Securing Cover

### Blade Tension & Tracking

From time to time it may be necessary to tension and track the bandsaw blade especially after replacement. Make sure the blade is all the way on the wheels and all blade guards are in place.

- Adjust the upper and lower guides away from the bandsaw blade.
- If installing a new blade turn the tension knob until there is a little tension on the blade in order for it to track sufficiently.
- With the cover open, spin the top wheel slowly. At the same time watch how the bandsaw blade tracks on the wheels.
- Add a little more tension making sure the bandsaw blade tracks on the crown of the wheel.
- The proper tension is approximately a 1/4" deflection with a little pressure placed on the side of the bandsaw blade with your finger.
- If the blade is tracking correctly no adjustment is needed.
- If the blade is not tracking, loosen the tracking adjustment lock knob so you can turn the tracking knob in or out.
- While spinning the upper wheel, slowly turn the tracking knob so the bandsaw blade tracks in the center of the wheel. You'll see the blade move one way or the other depending upon which way you turn the knob; either counter-clockwise or clockwise.
- Once tracking is set use the tracking lock knob to secure the blade tracking in position.
- Adjust the upper and lower blade guides. Guide adjustment section.
- Makes sure all covers, guards and parts are in place and secure.

### **⚠ WARNING**

Make sure the bandsaw is disconnected from the power source before making any adjustments.

Be careful in turning the bandsaw wheel by hand so as not to pinch fingers.



## Adjustments

### Blade Guide Adjustment

Proper guide adjust is important to the proper operation of the bandsaw and will extend the life of the bandsaw blade.

In general the guide bearings should be close enough to guide the bandsaw blade to control deflection during the cut but not tight against the blade.

Positioning the bearings too close against the blade causes too much friction and can work-harden the blade causing premature blade failure.

#### Upper Blade Guide

The set screws on the back of the upper guide A, B, and C are used to position the guide assembly along a shaft.

A moves the entire bearing block and B & C are used to center the bearing block to the blade.

- First make sure the shaft is flush with the block. Loosen A make flush and lock.
- To center the thrust bearing behind the back of the blade loosen set screws B & C center bearing block and tighten.
- To adjust the thrust bearing loosen the cap screw and move the bearing so it is approximately .015" away from the back of the blade and tighten. (Folding a piece of paper 4 times is close).
- Adjust the side bearings by loosening the corresponding cap screws and by moving the adjustment pins (D), to position the bearings within .004" of the blade and tighten. (Single paper thickness is fairly close).

#### Lower Blade Guide

The lower blade guide adjustments work in similar fashion as the upper guide. The block holds the bearing block in place along a shaft.

- The bearing block assembly can be adjusted along the shaft by loosening the set screw G positioning and then re-tightening.
- Loosen the set screws E & F. Center the bearing block to the blade and tighten.
- Adjust the side blade bearings by loosening the corresponding cap screws and slide the bearings to within .004" of the blade and tighten. (Single paper thickness is fairly close).

### **⚠ WARNING**

Make sure the bandsaw is disconnected from the power source before making any adjustments.

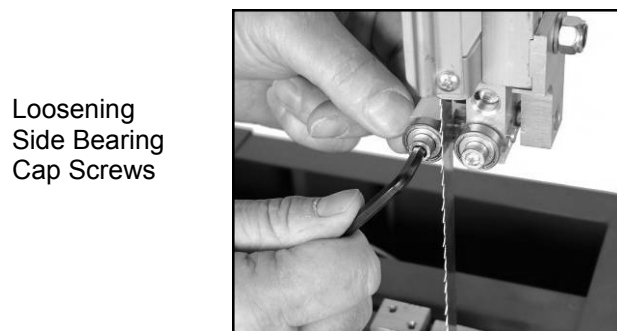
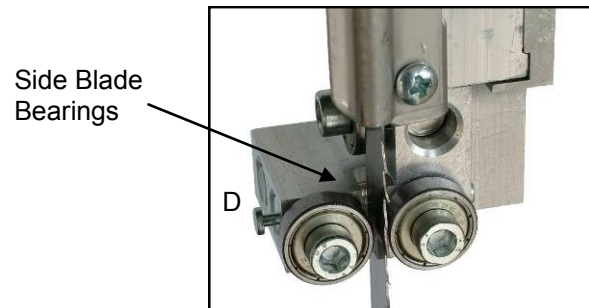
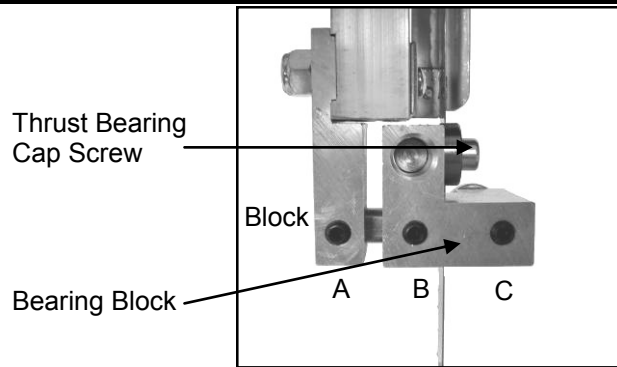

Loosening Side Bearing Cap Screws

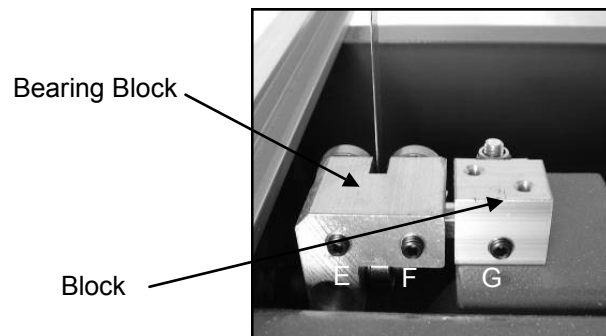

Loosening Side Bearing Cap Screws

## Processing Meat

### **⚠ WARNING**

Processing meat can be dangerous as meat is usually not uniform in size and can be slippery. The blade can cut fingers and other body parts. Use a push stick for sawing smaller pieces. Always use a stuffer/pusher when using the grinder.

Make sure meat is always safely supported during the cut and hands are away from the blade.

The meat saw and grinder need to be pre-cleaned before first-time use as it was assembled and packed to prevent corrosion.

Refer to OSHA compliance manuals, USDA or the appropriate local health association or board.

Be careful when using the grinder as it will operate once the bandsaw is turned on. Be aware that the bandsaw blade is running as well.

## Cutting Meat

The bandsaw will cut most fresh or frozen meat.

- Make sure the table slides smoothly and all stops are working and in place.
- Make sure the guides are adjusted properly and the bandsaw blade is tracking correctly.
- Adjust the fences so the meat is fully supported and for the desired thickness of cut. Make sure the fences will not come in contact with the blade.
- If you are just cutting meat with the bandsaw make sure the grinder is not attached.
- Once the power is on, slide the meat through slowly and evenly taking care to adjust for blade speed and loading especially when going through bone.
- Make successive cuts, clearing away the cut slice. Do this with care.
- Always be aware of what is happening during the cut and in the surrounding work area. This cannot be overstated.
- Store cut meat in a sanitary and clean area.
- Clean and sanitize the bandsaw after each use.

## Using the Grinder

The meat grinder is used to process meat into sausage and hamburger. It will not grind up bone or other hard material. Remember the grinder will operate once the bandsaw is turned on.

- All the grinder components must be clean and sanitized before using it to process meat.
- Make sure the grinder is put together and installed properly to the bandsaw.
- Do not operate the grinder dry.
- Make sure the upper blade guide is all the way down and locked in place.
- Prepare a clean and sanitary place for the ground meat.
- Attach sausage funnel if need be.

- Feed cubed meat, about 1-1/2" square, into the grinder. Do not feed any bone into the grinder.
- Always use the stuffer to push meat through the grinder. Never use your fingers for any reason.
- Store processed meat in a clean and sanitary place.
- Remove grinder from meat saw when not in use.
- Clean and sanitize the bandsaw and grinder completely and use the top feed cover when storing the grinder.

## Cleaning up

### **⚠ WARNING**

It is important to keep your meat cutting bandsaw clean and sanitized. Make sure bandsaw and all components are cleaned and sanitized before use and after it has been used to process meat.

Do not clean the bandsaw while it is plugged in or near any other electrical device or outlet. Do not spray water on the motor or switch. Severe injury or death may result.

Do not plug in the saw when it is still damp or wet.

After each use the bandsaw, grinder and components that have been in contact with meat/bone must be cleaned to prevent bacteria and other unhealthy particles from causing sickness or even death.

Be aware of the associated hazards in using any cleaner or sanitizer. Follow manufacturers recommendations on the label making sure the product is safe for food processing. Failure to do so may cause serious health issues or even death.

We cannot within the scope of this manual impart proper meat processing and sanitary practices in the operation of this meat processing bandsaw. It is your responsibility to research and understand the proper meat handling, processing, cleaning methods and operating practices.

Refer to OSHA compliance manuals, your local board of health and the USDA for proper meat handling methods, processing, sanitizing and cleaning of meat processing equipment.

- Remove the fences, sliding table, blade guards, blade, blood tray and grinder.
- Disassemble the grinder components if used.
- Carefully remove bandsaw blade.
- Clean and sanitize all components
- Clean and sanitize all other bandsaw parts and surfaces such as the bandsaw wheels and interior cabinet parts that have come in contact with food particles.
- A dishwasher makes it handy to clean parts and components.
- Bleach is a common sanitizing agent that can be used to clean and sanitize parts and surfaces.

# Parts Breakdown

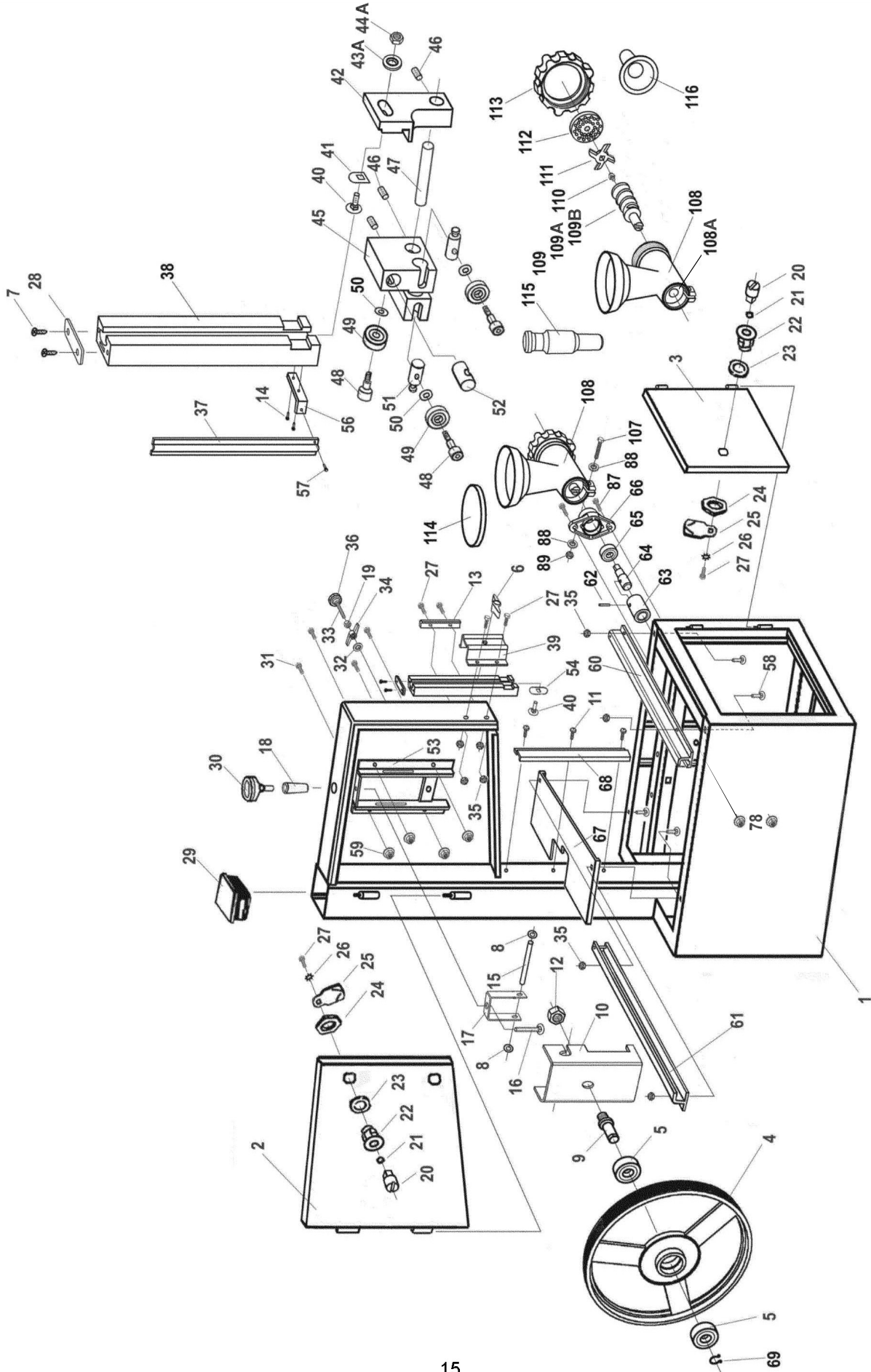

# Parts Breakdown

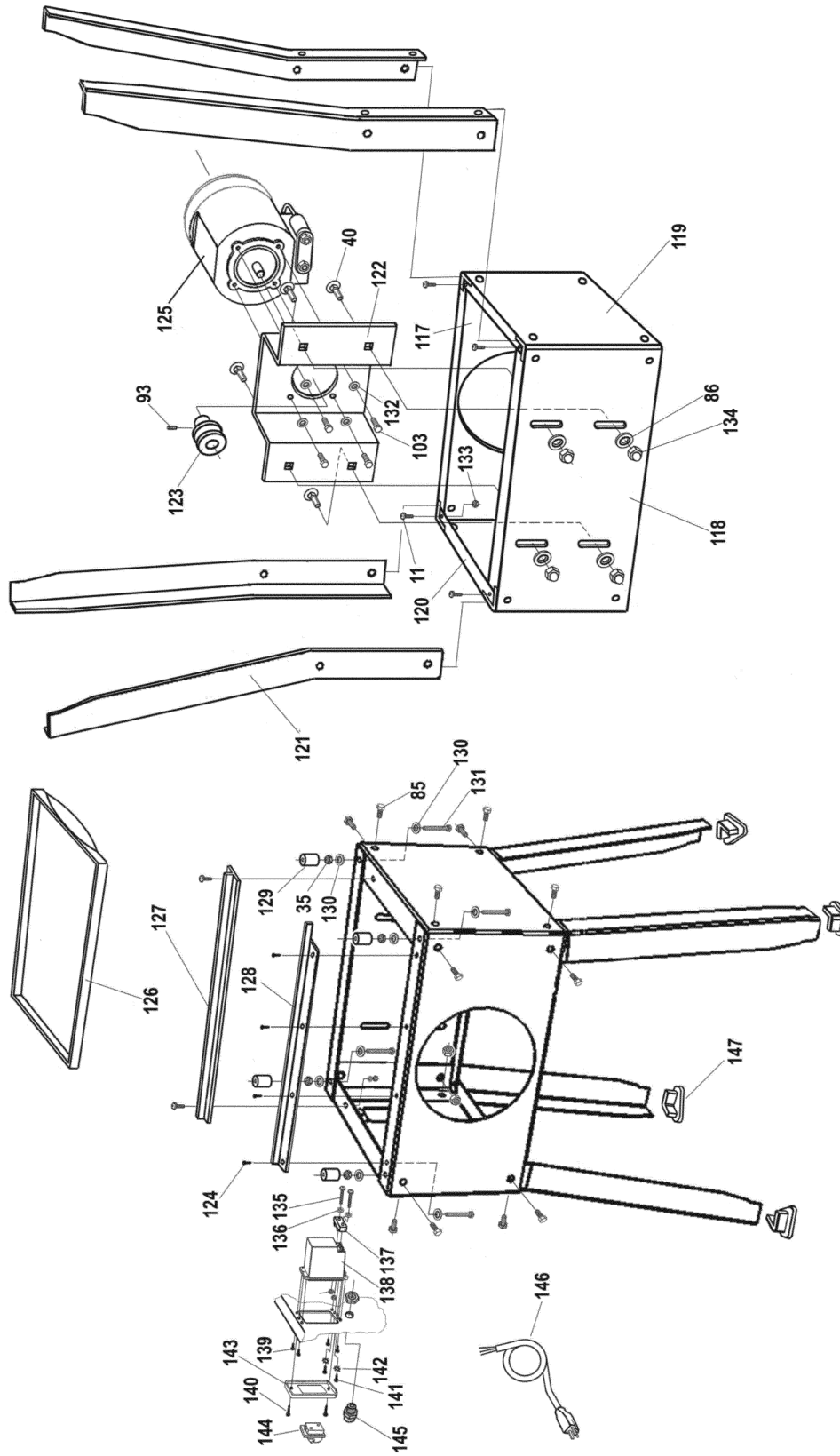

## Parts Breakdown & List

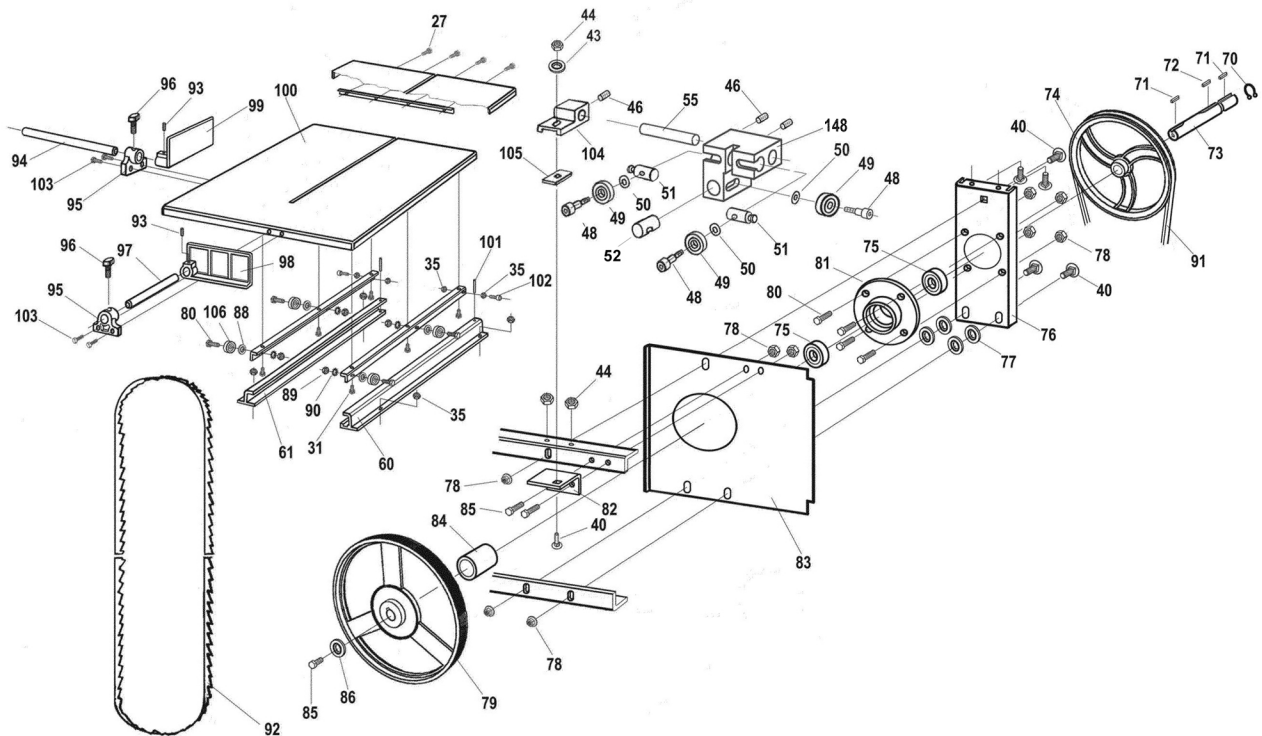

Key No.	Description
P10-308-1	MEAT SAW FRAME
P10-308-2	UPPER DOOR
P10-308-3	LOWER DOOR
P10-308-4	UPPER WHEEL
P10-308-5	BEARING 80202
P10-308-6	WING NUT KNOB
P10-308-7	TAP SCREW ST4.8 x 22
P10-308-8	RETAINING RING
P10-308-9	UPPER EARING SHAFT
P10-308-10	WHEEL CARRIER BRACKET
P10-308-11	PAN-HEAD PHILLIPS SCREW M5 x 10
P10-308-12	HEX NUT M14
P10-308-13	TWO HOLE PLATE
P10-308-14	PAN-HEAD PHILLIPS SCREW M4 x 8
P10-308-15	PARALLEL PIN
P10-308-16	CARRIAGE BOLT
P10-308-17	TENSION BRACKET
P10-308-18	BLADE TENSIONING ROD
P10-308-19	HEX NUT M6
P10-308-20	SLOTTED INSERT
P10-308-21	SPRING LOCK WASHER 10
P10-308-22	LOCK HOUSING
P10-308-23	NYLON WASHER

Key No.	Description
P10-308-24	HOUSING NUT M22 x 1.5
P10-308-25	TONGUE
P10-308-26	EXTERNAL WASHER 6
P10-308-27	HEX SCREW M6 x 12
P10-308-28	GUIDE CARRIER STOP
P10-308-29	FRAME TOP CAP
P10-308-30	BLADE TENSIONING KNOB
P10-308-31	HEX BOLT M6 x 12
P10-308-32	WASHER 6
P10-308-33	HEX BOLT M6 x 60
P10-308-34	WING NUT KNOB
P10-308-35	HEX NUT M6
P10-308-36	STAR KNOB SCREW
P10-308-37	BLADE GUIDE
P10-308-38	GUIDE CARRIER EXTRUSION
P10-308-39	GUIDE CARRIER MOUNT
P10-308-40	CARRIAGE BOLT M8 x 20
P10-308-41	SQUARE HOLE PLATE
P10-308-42	MOUNT BLADE GUIDE
P10-308-43	WASHER 8
P10-308-43A	WASHER 10
P10-308-44	HEX NUT M8
P10-308-44A	HEX NUT M10

## Parts List

Key No.	Description	Key No.	Description
P10-308-45	UPPER GUIDE BODY	P10-308-98	PUSHING FENCE
P10-308-46	SOCKET SET SCREW M6 x 10	P10-308-99	SIDE FENCE
P10-308-47	UPPER GUIDE SHAFT	P10-308-100	TABLE
P10-308-48	SPECIAL SCREW	P10-308-101	ROLL PIN 4 x 30
P10-308-49	BEARING 80026	P10-308-102	SOCKET SET SCREW M6 x 20
P10-308-50	WASHER 6	P10-308-103	HEX BOLT M6 x 16
P10-308-51	BEARING MOUNTING SHAFT - 1	P10-308-104	LOWER BLADE GUIDE MOUNT
P10-308-52	BEARING MOUNTING SHAFT - 2	P10-308-105	FLAT PIECE
P10-308-53	TENSION BRACKET FRAME	P10-308-106	BEARING 80018
P10-308-54	BOLT GUIDE	P10-308-107	HEX BOLT M8 x 60
P10-308-55	LOWER GUIDE SHAFT	P10-308-108	GRINDER HOPPER
P10-308-56	BRACKET FOR BLADE GUIDE	P10-308-109	WORM DRIVE SHAFT
P10-308-57	PAN HEAD PHILLIPS SCREW M6 x 16	P10-308-109A	GRINDER DRIVE SHAFT
P10-308-58	HEX BOLT M6 x 16	P10-308-109B	PLASTIC WASHER
P10-308-59	FLANGE NUT M6	P10-308-110	SQUARE HEAD SCREW M10
P10-308-60	LEFT RAIL - TABLE	P10-308-111	REAMER / BLADE
P10-308-61	RIGHT RAIL - TABLE	P10-308-112	GRINDING PLATE
P10-308-62	ROLL PIN 8 X 26	P10-308-113	LOCK COVER
P10-308-63	BUSHING	P10-308-114	PLASTIC HOPPER COVER
P10-308-64	SHAFT FOR GRINDER	P10-308-115	MEAT PUSHING ROD
P10-308-65	BEARING 80203	P10-308-116	RUBBER TUBE CONNECTOR
P10-308-66	BRACKET FOR GRINDER	P10-308-117	FRONT PANEL OF STAND
P10-308-67	LOWER FRAME PLATE	P10-308-118	REAR PANEL OF STAND
P10-308-68	BLADE COVER	P10-308-119	LEFT PANEL OF STAND
P10-308-69	RETAINING RING 15	P10-308-120	RIGHT PANEL OF STAND
P10-308-70	RETAINING RING 20	P10-308-121	LEG
P10-308-71	MACHINE KEY 5 x 5 x 20	P10-308-122	MOTOR MOUNT FRAME
P10-308-72	MACHINE KEY 5 x 5 x 30	P10-308-123	MOTOR PULLEY
P10-308-73	DRIVE SHAFT	P10-308-124	RIVET 4 x 8
P10-308-74	DRIVE PULLEY	P10-308-125	MOTOR 3/4HP, 110V, 60Hz, 5A
P10-308-75	BEARING 80104	P10-308-126	CHIP AND BLOOD TRAY
P10-308-76	BEARING MOUNTING PLATE	P10-308-127	CHIP TRAY RAIL - 1
P10-308-77	WASHER 10	P10-308-128	CHIP TRAY RAIL - 2
P10-308-78	FLANGE NUT M8	P10-308-129	SPACER BUSHING
P10-308-79	LOWER WHEEL	P10-308-130	WASHER 6
P10-308-80	HEX BOLT M8 x 20	P10-308-131	HEX BOLT M6 x 40
P10-308-81	FLANGE	P10-308-132	SPRING LOCK WASHER 6
P10-308-82	ANGLE PLATE	P10-308-133	HEX NUT M5
P10-308-83	FRAME SEPARATION PLATE	P10-308-134	CAP NUT M8
P10-308-84	REIN SLEEVE	P10-308-135	PAN - HEAD PHILLIPS SCREW M4 x 35
P10-308-85	HEX BOLT M8 x 16	P10-308-136	WASHER 5
P10-308-86	WASHER M8	P10-308-137	CLAMP FOR CORD
P10-308-87	BOLT M8 x 30	P10-308-138	BOX FOR SWITCH
P10-308-88	WASHER M8	P10-308-139	TAPE SCREW ST3.5 x 12
P10-308-89	HEX NUT M8	P10-308-140	TAPE SCREW ST3.5 x 20
P10-308-90	EXTERNAL WASHER 8	P10-308-141	PAN - HEAD PHILLIPS SCREW M4 x 14
P10-308-91	DRIVE BELT	P10-308-142	EXTERNAL WASHER 4
P10-308-92	BANDSAW BLADE 1950MM / 76-3/4"L	P10-308-143	COVER FOR SWITCH
P10-308-93	SOCKET SET SCREW M8 x 12	P10-308-144	ON/OFF SWITCH WITH LOCK
P10-308-94	SUPPORT ROD (10")	P10-308-145	CORD STRAIN RELIEF
P10-308-95	SUPPORT ROD HOLDER	P10-308-146	CORD WITH PLUG
P10-308-96	WING NUT KNOB	P10-308-147	RUBBER FOOT SHOE
P10-308-97	SUPPORT ROD (7")	P10-308-148	LOWER GUIDE BODY

## Warranty

### Note

We make every effort to be accurate with our pricing, specifications, copy, images and other product information and apologize for any errors that may occur. This information, while deemed accurate, is not guaranteed.

We reserve the right to make changes to all products including specifications, pricing and availability.

# **RIKON**

## **POWER TOOLS**

### **5-year Limited WARRANTY**

**RIKON Power Tools, Inc.** (“Seller”) warrants to only the original retail consumer/purchaser of our products that each product be free from defects in materials and workmanship for a period of five (5) years from the date the product was purchased at retail. This warranty may not be transferred.

This warranty does not apply to defects due directly or indirectly to misuse, abuse, negligence, accidents, repairs, alterations, lack of maintenance or normal wear and tear. Under no circumstances will Seller be liable for incidental or consequential damages resulting from defective products. All other warranties, expressed or implied, whether of merchantability, fitness for purpose, or otherwise are expressly disclaimed by Seller. This warranty does not cover products used for commercial, industrial or educational purposes. This limited warranty does not apply to accessory items such as blades, drill bits, sanding discs or belts and other related items.

Seller shall in no event be liable for death, injuries to persons or property, or for incidental, contingent, special, or consequential damages arising from the use of our products. To take advantage of this warranty, contact us by mail, phone, or e-mail. Proof of purchase documentation, which includes date of purchase and an explanation of the complaint, must be provided.

The Seller reserves the right to effect at any time, without prior notice, those alterations to parts, fittings, and accessory equipment which they may deem necessary for any reason whatsoever.

To take advantage of the warranty, please fill out the warranty card that was enclosed with the machine and send it to: RIKON Power Tools, Inc.

The warranty card must be completely filled out and legible for it to be valid. If you have any questions please contact us at 877-884-5167 or [warranty@rikontools.com](mailto:warranty@rikontools.com).



**For more information:  
16 Progress Rd  
Billerica, MA 01821**

**877-884-5167/978-528-5380  
techsupport@rikontools.com**