

18" Wood/Metal Bandsaw



Shown with optional
Mobility Kit 13-345



Operator's Manual

Record the serial number and date of purchase in your manual for future reference.

The serial number can be found on the specification label on the rear of your machine.

Serial Number: _____ Date of purchase: _____

For technical support or parts questions, email techsupport@rikontools.com or call toll free at (877)884-5167

TABLE OF CONTENTS

Specifications.....	2
Safety Instructions	3 - 6
Contents of Package	7 - 8
Getting To Know Your Machine	9
Assembly	10 - 13
Adjustments.....	13 - 18
Operation	19 - 20
Electricals & Wiring Diagram	5 & 20
Maintenance	21
Notes	21 & 38
Troubleshooting	22 - 25
Parts Diagrams & Parts Lists	26 - 35
'How To' Guide for all Band Saw Blades	36
Accessories	37
Warranty	39

SPECIFICATIONS

Motor	2.5 HP, TEFC
Motor Speed (no load).....	1,400 RPM
Volts	220 V
Amps, Hertz, Phase	12.5 A, 60 Hz, 1Ph
Blade Length	142" (3,607 mm)
Blade Width Range	1/4" to 1-1/4" (6.35 to 31.75 mm)
Blade Speed Range (2)	82-1,312 or 328-3,280 ft/min
Table Size (W x D)	21" x 19" (533 mm x 483 mm)
Table Tilt	Left -10°, Right 45°
Miter Gauge Slot (2)	3/4" x 3/8" (19 x 9.5mm)
Maximum Cutting Width (throat)	18-3/8" (467 mm)
Maximum Cutting Depth (height)	12" (305 mm)
Table Height	37-3/4" (959 mm)
Fence Height	4-3/8" (111 mm)
Fence Length	20" (508 mm)
Dust Ports (2)	4" Diameter (100 mm)
Base Size (LxWxH)	29-15/16" x 18-1/8" x 2-7/16" (760x460x62 mm)
Overall Height	76" (1,930 mm)
Overall Size (HxWxD)...	76" x 38-7/16" x 29-1/2" (1,930 x 976 x 749 mm)
Net Weight	372 lbs (169 kg)

NOTE: The specifications, photographs, drawings and information in this manual represent the current model when the manual was prepared. Changes and improvements may be made at any time, with no obligation on the part of Rikon Power Tools, Inc. to modify previously delivered units. Reasonable care has been taken to ensure that the information in this manual is correct, to provide you with the guidelines for the proper safety, assembly and operation of this machine.

SAFETY INSTRUCTIONS

IMPORTANT! Safety is the single most important consideration in the operation of this equipment. **The following instructions must be followed at all times.** Failure to follow all instructions listed below may result in electric shock, fire, and/or serious personal injury.

There are certain applications for which this tool was designed. We strongly recommend that this tool not be modified and/or used for any other application other than that for which it was designed. If you have any questions about its application, do not use the tool until you have contacted us and we have advised you.

SAFETY SYMBOLS



SAFETY ALERT SYMBOL: Indicates DANGER, WARNING, or CAUTION. This symbol may be used in conjunction with other symbols or pictographs.



Indicates an imminently hazardous situation, which, if not avoided, could result in death or serious injury.



Indicates a potentially hazardous situation, which, if not avoided, could result in death or serious injury.



Indicates a potentially hazardous situation, which, if not avoided, could result in minor or moderate injury.

NOTICE: Shown without Safety Alert Symbol indicates a situation that may result in property damage.

GENERAL SAFETY

KNOW YOUR POWER TOOL. Read the owner's manual carefully. Learn the tool's applications, work capabilities, and its specific potential hazards.

BEFORE USING YOUR MACHINE

To avoid serious injury and damage to the tool, read and follow all of the Safety and Operating Instructions before operating the machine.

1. Some dust created by using power tools contains chemicals known to the State of California to cause cancer, birth defects, or other reproductive harm.

Some examples of these chemicals are:

- Lead from lead-based paints.
- Crystalline silica from bricks, cement, and other masonry products.
- Arsenic and chromium from chemically treated lumber.

Your risk from these exposures varies, depending on how often you do this type of work. To reduce your exposure to these chemicals: work in a well ventilated area and work with approved safety equipment, such as those dust masks that are specially designed to filter out microscopic particles.

2. **READ** the entire Owner's Manual. **LEARN** how to use the tool for its intended applications.

3. **GROUND ALL TOOLS.** If the tool is supplied with a 3 prong plug, it must be plugged into a 3-contact electrical receptacle. The 3rd prong is used to ground the tool and provide protection against accidental electric shock. **DO NOT** remove the 3rd prong. See Grounding Instructions on the following pages.

4. **AVOID A DANGEROUS WORKING ENVIRONMENT.** **DO NOT** use electrical tools in a damp environment or expose them to rain.

5. **DO NOT** use electrical tools in the presence of flammable liquids or gasses.

6. **ALWAYS** keep the work area clean, well lit, and organized. **DO NOT** work in an environment with floor surfaces that are slippery from debris, grease, and wax.

7. **KEEP VISITORS AND CHILDREN AWAY. DO NOT** permit people to be in the immediate work area, especially when the electrical tool is operating.

8. **DO NOT FORCE THE TOOL** to perform an operation for which it was not designed. It will do a safer and higher quality job by only performing operations for which the tool was intended.

9. **WEAR PROPER CLOTHING. DO NOT** wear loose clothing, gloves, neckties, or jewelry. These items can get caught in the machine during operations and pull the operator into the moving parts. The user must wear a protective cover on their hair, if the hair is long, to prevent it from contacting any moving parts.

10. **CHILDPROOF THE WORKSHOP AREA** by removing switch keys, unplugging tools from the electrical receptacles, and using padlocks.

11. **ALWAYS UNPLUG THE TOOL FROM THE ELECTRICAL RECEPTACLE** when making adjustments, changing parts or performing any maintenance.

SAFETY INSTRUCTIONS

12. KEEP PROTECTIVE GUARDS IN PLACE AND IN WORKING ORDER.

13. AVOID ACCIDENTAL STARTING. Make sure that the power switch is in the “OFF” position before plugging in the power cord to the electrical receptacle.

14. REMOVE ALL MAINTENANCE TOOLS from the immediate area prior to turning “ON” the machine.

15. USE ONLY RECOMMENDED ACCESSORIES. Use of incorrect or improper accessories could cause serious injury to the operator and cause damage to the tool. If in doubt, check the instruction manual that comes with that particular accessory.

16. NEVER LEAVE A RUNNING TOOL UNATTENDED. Turn the power switch to the “OFF” position. **DO NOT** leave the tool until it has come to a complete stop.

17. DO NOT STAND ON A TOOL. Serious injury could result if the tool tips over, or you accidentally contact the tool.

18. DO NOT store anything above or near the tool where anyone might try to stand on the tool to reach it.

19. MAINTAIN YOUR BALANCE. DO NOT extend yourself over the tool. Wear oil resistant rubber soled shoes. Keep floor clear of debris, grease, and wax.

20. MAINTAIN TOOLS WITH CARE. Always keep tools clean and in good working order. Keep all blades and tool bits sharp, dress grinding wheels and change other abrasive accessories when worn.

21. EACH AND EVERY TIME, CHECK FOR DAMAGED PARTS PRIOR TO USING THE TOOL. Carefully check all guards to see that they operate properly, are not damaged, and perform their intended functions. Check for alignment, binding or breaking of moving parts. A guard or other part that is damaged should be immediately repaired or replaced.

22. DO NOT OPERATE TOOL WHILE TIRED, OR UNDER THE INFLUENCE OF DRUGS, MEDICATION OR ALCOHOL.

23. SECURE ALL WORK. Use clamps or jigs to secure the work piece. This is safer than attempting to hold the work piece with your hands.

24. STAY ALERT, WATCH WHAT YOU ARE DOING, AND USE COMMON SENSE WHEN OPERATING A POWER TOOL.

A moment of inattention while operating power tools may result in serious personal injury.

25. ALWAYS WEAR A DUST MASK TO PREVENT INHALING DANGEROUS DUST OR AIRBORNE PARTICLES, including wood dust, crystalline silica dust and asbestos dust. Direct particles away from face and body. Always operate tool in well ventilated area and provide for proper dust removal. Use dust collection system wherever possible. Exposure to the dust may cause serious and permanent respiratory or other injury, including silicosis (a serious lung disease), cancer, and death. Avoid breathing the dust, and avoid prolonged contact with dust. Allowing dust to get into your mouth or eyes, or lay on your skin may promote absorption of harmful material. Always use properly fitting NIOSH/OSHA approved respiratory protection appropriate for the dust exposure, and wash exposed areas with soap and water.

26. USE A PROPER EXTENSION CORD IN GOOD CONDITION. When using an extension cord, be sure to use one heavy enough to carry the current your product will draw. The table on the following page shows the correct size to use depending on cord length and nameplate amperage rating. If in doubt, use the next heavier gauge. The smaller the gauge number, the larger diameter of the extension cord. If in doubt of the proper size of an extension cord, use a shorter and thicker cord. An undersized cord will cause a drop in line voltage resulting in a loss of power and overheating.
USE ONLY A 3-WIRE EXTENSION CORD THAT HAS A 3-PRONG GROUNDING PLUG AND A 3-POLE RECEPTACLE THAT ACCEPTS THE TOOL’S PLUG.

27. ADDITIONAL INFORMATION regarding the safe and proper operation of this product is available from:

- Power Tool Institute
1300 Summer Avenue
Cleveland, OH 44115-2851
www.powertoolinstitute.org
- National Safety Council
1121 Spring Lake Drive
Itasca, IL 60143-3201
www.nsc.org
- American National Standards Institute
25 West 43rd Street, 4th Floor
New York, NY 10036
www.ansi.org
- ANSI 01.1 Safety Requirements for Woodworking Machines and the U.S. Department of Labor regulations
www.osha.gov

28. SAVE THESE INSTRUCTIONS. Refer to them frequently and use them to instruct others.

SAFETY INSTRUCTIONS

ELECTRICAL SAFETY

⚠ WARNING: THIS TOOL MUST BE GROUNDED WHILE IN USE TO PROTECT THE OPERATOR FROM ELECTRIC SHOCK.

IN THE EVENT OF A MALFUNCTION OR BREAKDOWN, grounding provides the path of least resistance for electric current and reduces the risk of electric shock. This tool is equipped with an electric cord that has an equipment grounding conductor and requires a grounding plug (not included). The plug **MUST** be plugged into a matching electrical receptacle that is properly installed and grounded in accordance with **ALL** local codes and ordinances.

DO NOT MODIFY ANY PLUG. If it will not fit the electrical receptacle, have the proper electrical receptacle installed by a qualified electrician.

IMPROPER ELECTRICAL CONNECTION of the equipment grounding conductor can result in risk of electric shock. The conductor with the green insulation (with or without yellow stripes) is the equipment grounding conductor. **DO NOT** connect the equipment grounding conductor to a live terminal if repair or replacement of the electric cord or plug is necessary.

CHECK with a qualified electrician or service personnel if you do not completely understand the grounding instructions, or if you are not sure the tool is properly grounded when installing or replacing a plug.

USE ONLY A 3-WIRE EXTENSION CORD THAT HAS THE PROPER TYPE OF A 3-PRONG GROUNDING PLUG THAT MATCHES THE MACHINE'S 3-PRONG PLUG AND ALSO THE 3-POLE RECEPTACLE THAT ACCEPTS THE TOOL'S PLUG. *

REPLACE A DAMAGED OR WORN CORD IMMEDIATELY.

This tool is intended for use on a circuit that has a 120 volt electrical receptacle. **FIGURE A** shows the type of the 220v, 3-wire electrical plug and electrical receptacle that has a grounding conductor that is required if the motor wiring is changed. See page 21.

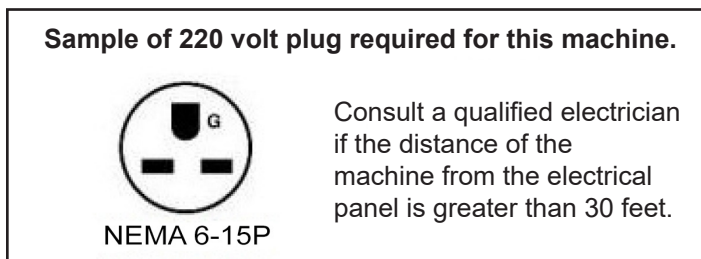

FIG. A

EXTENSION CORDS

⚠ WARNING: THE USE OF AN EXTENSION CORD WITH THIS MACHINE IS NOT RECOMMENDED. For best power and safety, plug the machine directly into a dedicated, grounded electrical outlet that is within the supplied cord length of the machine.

If an extension cord needs to be used, it should only be for a limited operation of the machine. The extension cord should be as short as possible in length, and have a minimum gauge size of 14AWG.

⚠ WARNING: Check extension cords before each use. If damaged replace immediately. Never use a tool with a damaged cord, since touching the damaged area could cause electrical shock, resulting in serious injury.

Use a proper extension cord. Only use cords listed by Underwriters Laboratories (UL). Other extension cords can cause a drop in line voltage, resulting in a loss of power and overheating of tool. When operating a power tool outdoors, use an outdoor extension cord marked "W-A" or "W". These cords are rated for outdoor use and reduce the risk of electric shock.

MINIMUM RECOMMENDED GAUGE FOR EXTENSION CORDS (AWG)

120 VOLT OPERATION ONLY				
	25' LONG	50' LONG	100' LONG	150' LONG
0 to 6 Amps	18 AWG	16 AWG	16 AWG	14 AWG
6 to 10 Amps	18 AWG	16 AWG	14 AWG	12 AWG
10 to 12 Amps	16 AWG	16 AWG	14 AWG	12 AWG

⚠ WARNING: Keep the extension cord clear of the working area. Position the cord so that it will not get caught on lumber, tools or other obstructions while you are working with your power tool.

* Canadian electrical codes require extension cords to be certified SJT type or better.

** The use of an adapter in Canada is not acceptable.



THIS SYMBOL DESIGNATES THAT THIS TOOL IS LISTED BY THE INTERTEK TESTING SERVICES, TO UNITED STATES AND CANADIAN STANDARDS.

SAFETY INSTRUCTIONS

SPECIFIC SAFETY INSTRUCTIONS FOR BAND SAWS

This machine is intended for the cutting of natural, solid woods, composite materials, plastics and non-ferrous metals. The permissible workpiece dimensions must be observed (see Technical Specification). Any other use not as specified, including modification of the machine or use of parts not tested and approved by the equipment manufacturer, can cause unforeseen damage and invalidate the warranty.

ATTENTION: Use of this band saw still presents risks that cannot be eliminated by the manufacturer. Therefore, the user must be aware that wood working machines are dangerous if not used with care and all safety precautions are adhered to.

1. Do not operate this machine until you have read all of the following instructions.
2. If you are not familiar with the operation of the machine, obtain assistance from a qualified person.
3. Always wear approved, safety protective eye wear and hearing protection when operating this machine.
4. Always wear a dust mask and use adequate dust collection and proper ventilation.
5. Adjust the upper guides about 1/8" to 1/4" above the material being cut.
6. Check for proper blade size and type for the thickness and type of material being cut.
7. Make sure that the blade tension and blade tracking are properly adjusted.
8. Always keep hands and fingers away from the blade.
9. Make "relief" cuts before cutting curves to eliminate blade binding.
10. Always hold material firmly, resting flat on the table and feed it into the blade at a moderate speed.
11. Never attempt to saw stock that does not have a flat surface, unless a suitable support is used.
12. When cutting small work pieces, always use a push stick, holding jig or other device to keep your hands safely away from the blade. Use 'Zero Clearance Inserts' to prevent small pieces from becoming jammed in the table insert or lower blade guides.
13. Always allow the bandsaw blade to stop before removing scrap pieces from the table.
14. Do not remove jammed pieces from the saw until the machine and blade has stopped. Unplug the bandsaw from the power source, and then remove the jammed work piece.
15. Always turn off the machine if the material is to be backed out of an uncompleted cut.
16. Use extra supports (roller stands, saw horses, tables etc.) for any work pieces large enough to tip when not held down to the table top surface.
17. Always turn off and unplug the machine when changing blades or servicing the machine.
18. Release blade tension when the saw will not be used for a long period of time.
19. Remove material or debris from the work area. Keep work area neat and clean.

SAVE THESE INSTRUCTIONS.

Refer to them often.

This owner's manual is not a teaching aid. Use of this owner's manual is intended to show assembly, adjustments, and general use.

California Proposition 65 Warning



WARNING: Drilling, sawing, sanding or machining wood products can expose you to wood dust, a substance known to the State of California to cause cancer. Avoid inhaling wood dust or use a dust mask or other safeguards for personal protection. For more information go to www.P65Warnings.ca.gov/wood.

CONTENTS OF PACKAGE

Model 10-370 18" Wood/Metal Bandsaw is shipped complete in one crate.

Unpacking, Checking Contents & Clean-up

1. Carefully remove all contents from the shipping carton. Compare the contents with the list of contents to make sure that all of the items are accounted for, before discarding any packing material. Place parts on a protected surface for easy identification and assembly. If any parts are missing or broken, please call RIKON Customer Service (877-884-5167) as soon as possible for replacements. DO NOT turn your machine ON if any of these items are missing. You may cause injury to yourself or damage to the machine.
2. Report any shipping damage to your local distributor. Take photographs for any possible insurance claims.
3. With the help of another person, unbolt the bandsaw from the packing pallet. Carefully lift the bandsaw off the packing pallet and place it on a level floor.
4. Clean all rust protected surfaces with ordinary house hold type grease or spot remover. Do not use; gasoline, paint thinner, mineral spirits, etc. These may damage painted surfaces.
5. Apply a coat of paste wax to the table to prevent rust. Wipe all parts thoroughly with a clean dry cloth. Be careful, as the pre-installed bandsaw blade has sharp teeth and may cause injury if touched.
6. Set packing material and shipping carton aside. Do not discard until the machine has been set up and is running properly.

TABLE OF LOOSE PARTS

Item	Part Name	Qty
A.	Bandsaw Assembly	1
B.	Table with insert	1
C.	Owner's Manual	1
D.	Parts Package 1	1
E.	Parts Package 2	1



(B)



(D)

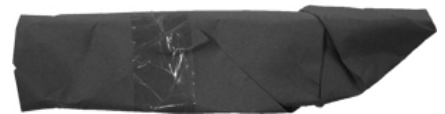

(C)



(E)



See page 8 for the list of loose parts that are sent along with the crated bandsaw for assembly.

LOOSE PARTS LIST

LIST OF LOOSE PARTS

Table Assembly:

- A. Table
- B. Table leveling bar and hardware
(may be pre-assembled on the table)
- C. 90° Table stop bolt
- D. Table mounting bolts and washers

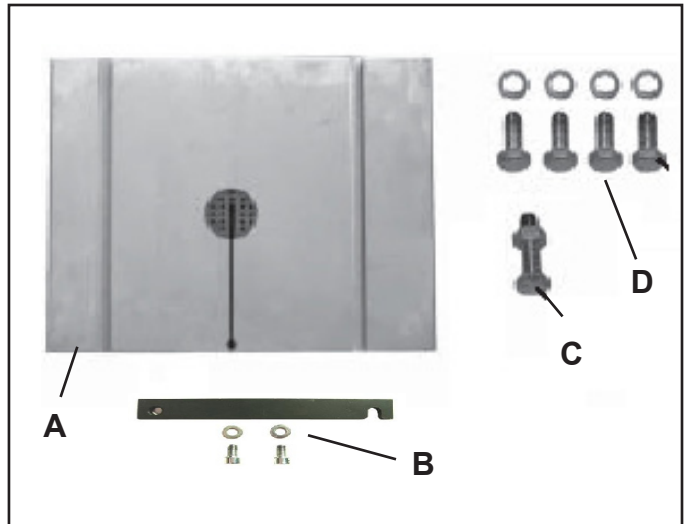

Rip Fence Assembly:

- A. Fence bar and hardware
- B. Rip fence
- C. Re-saw bar and hardware
- D. Fence carrier and hardware

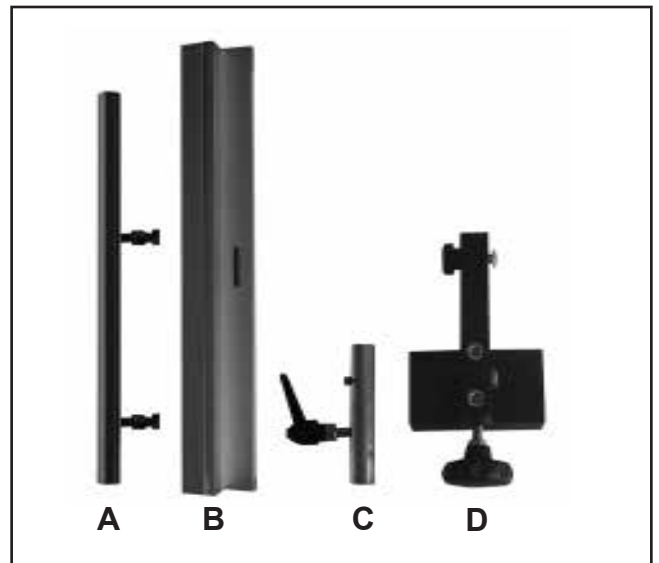

Tool Holder Assembly:

- A. Hex wrench 3MM
- B. Hex wrench 4MM
- C. Hex wrench 5MM
- D. Hex wrench 6MM
- E. Tool holder (may be pre-assembled on the column)
- F. Tool holder mounting screws

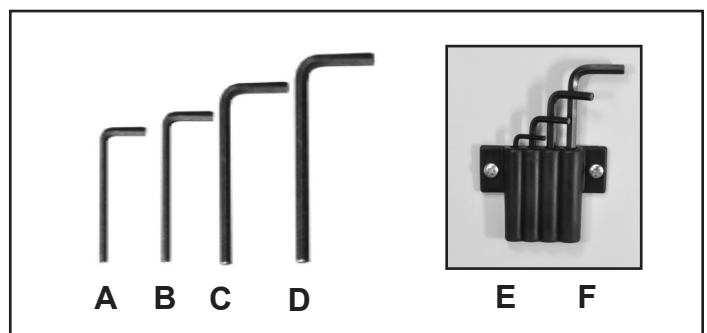

Additional Tools Required - not supplied:

- Slotted Screwdriver
- #2 Phillips Screwdriver
- Wrenches: 13mm or Adjustable

⚠ WARNING: THE MACHINE MUST NOT BE PLUGGED IN AND THE POWER SWITCH MUST BE IN THE OFF POSITION UNTIL ASSEMBLY OF THE PARTS AND ALL ADJUSTMENTS ARE COMPLETE.

GETTING TO KNOW YOUR MACHINE

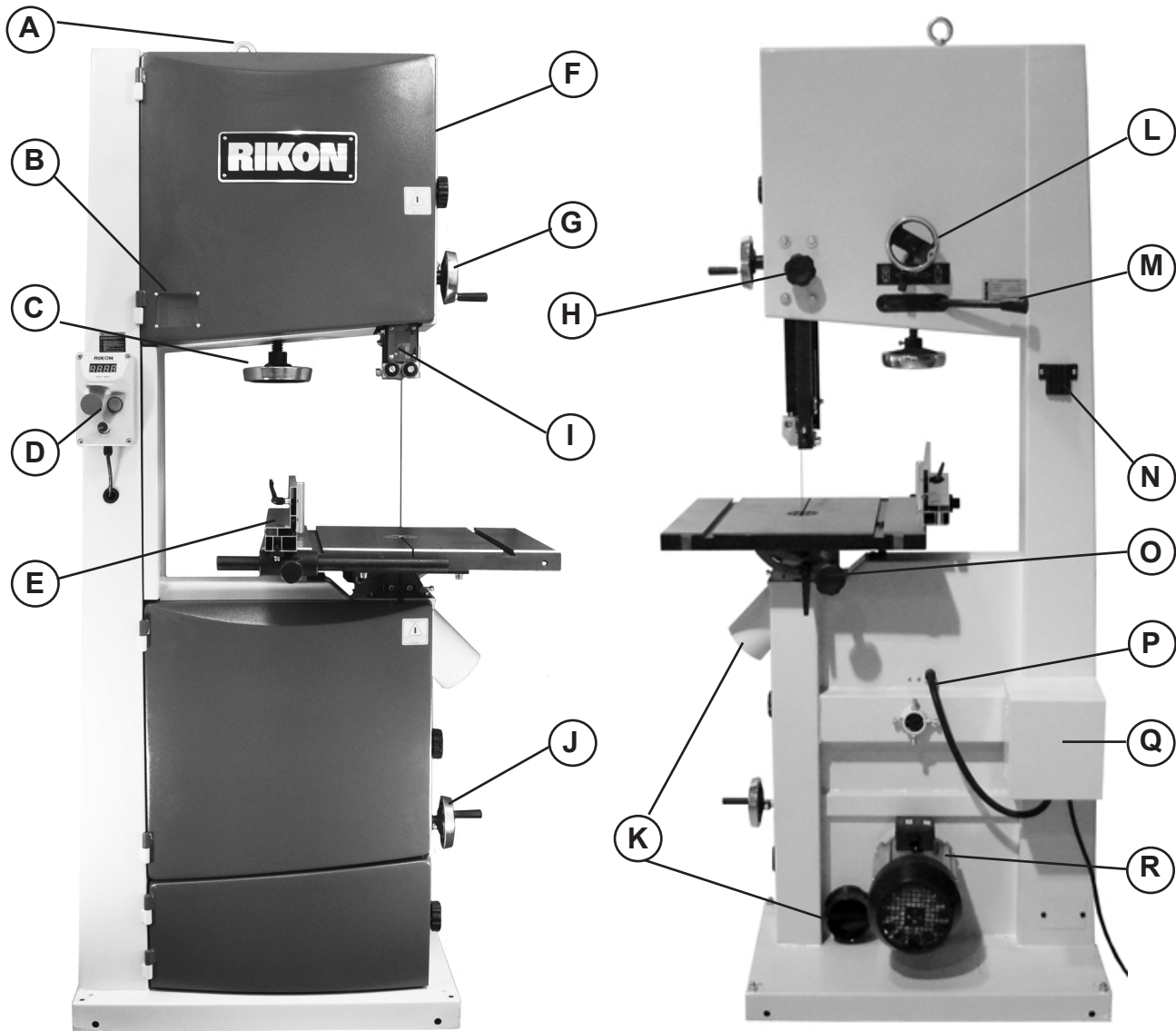

- A. Ring - to secure saw during transport
- B. Tension Indicator Window
- C. Blade Tension Hand Wheel
- D. On/Off Switch
- E. Rip Fence
- F. Blade Tracking Window
- G. Guide Post Hand Wheel
- H. Guide Post Lock Knob
- I. Hinged Blade Guard

- J. Drive Belt Tension Wheel
- K. 4" Dust Ports
- L. Blade Tracking Knob
- M. Quick Release Lever
- N. Tool Holder
- O. Table Tilt & Lock Knobs
- P. Speed Sensor Cable
- Q. VFD Control Housing
- R. Motor

ASSEMBLY

The 10-370 Bandsaw is supplied partly assembled. Prior to use, the following items have to be assembled: switch, working table, rip fence and hand wheels.

Warning!

To ensure sufficient upright stability and safety of this bandsaw, you need to bolt the bandsaw to the floor with lag bolts, or screws (not supplied) through the pre-drilled holes in the base. Fig. 1.

⚠ WARNING: THE MACHINE MUST NOT BE PLUGGED IN AND THE POWER SWITCH MUST BE IN THE OFF POSITION UNTIL ASSEMBLY OF THE PARTS AND ALL ADJUSTMENTS ARE COMPLETE.

INSTALLING THE SWITCH BOX

If the switchbox has not been pre-installed, follow the steps below for installation.

1. Remove the two screws (#19A) that were pre-installed on the front of the bandsaw column. FIG. 2, A. These screws will be used to mount the switch box to the column.

2. Loosen the four screws that are located on the front corners of the switch box with a slotted screw driver. Carefully separate the control panel from the switch box. FIG. 3, B.

Caution!

Take extra care when handling the control panel, as wires are attached to the switch box. Do not allow the control panel to be supported or hang by the wiring as damage can occur to the electronics.



FIG. 1



FIG. 2



FIG. 3

Continued on page 11

ASSEMBLY

Installing the Switch Box - continued

3. Mount the switch to the front of the band saw column by using the corresponding holes in the back of the switch box. FIG. 4, A. Use the same two screws that were removed from the frame shown in Fig. 2, step #1 to mount the switch box to the column.

4. Next, re-install the control panel onto the switch box, previously removed in step 2, FIG. 3. Make sure that the wires in the switch box do not become cut or pinched while installing the control panel. Tighten the four control panel screws with a flat-head screw driver.

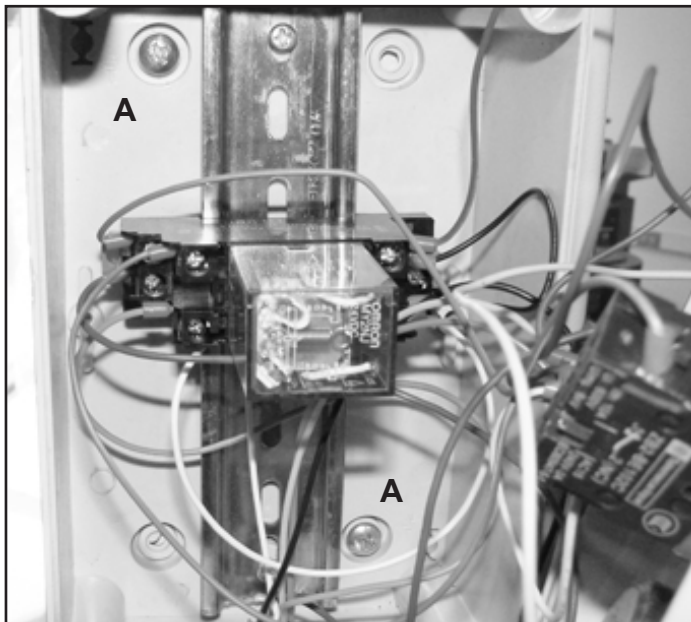

FIG. 4

Caution!

Take extra care when handling the control panel, as wires are attached to the switch box. Do not allow the control panel to be supported or hang by the wiring as damage can occur to the electronics.

WORK TABLE ASSEMBLY

Installing 90° table stop:

If the table stop has not been pre-installed, follow the steps below for installation.

1. Thread the M8x20 machine bolt (#76B) and M8 nut (#62B) to the pre-drilled and tapped hole in the bottom of the cast iron table. FIG. 5.
2. With the help of another person, lift the work table onto the trunnion (#52B). FIG. 6, A.
3. Fasten the work table to the trunnion using the supplied (4) hex bolts, (4) lock washers and (4) washers (#53B, 56B, 70B). FIG. 6, B.

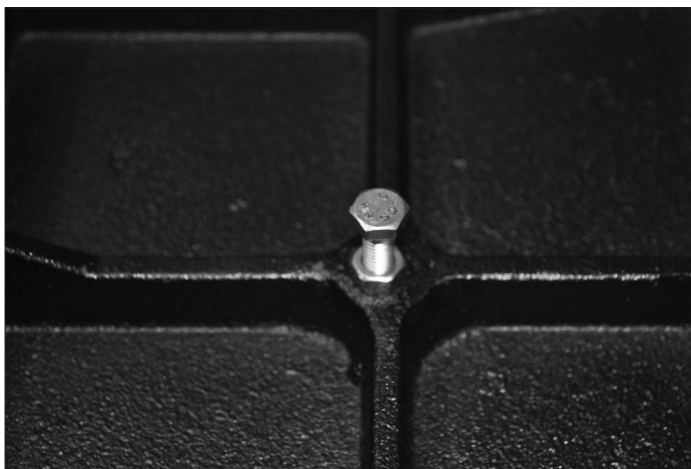

FIG. 5

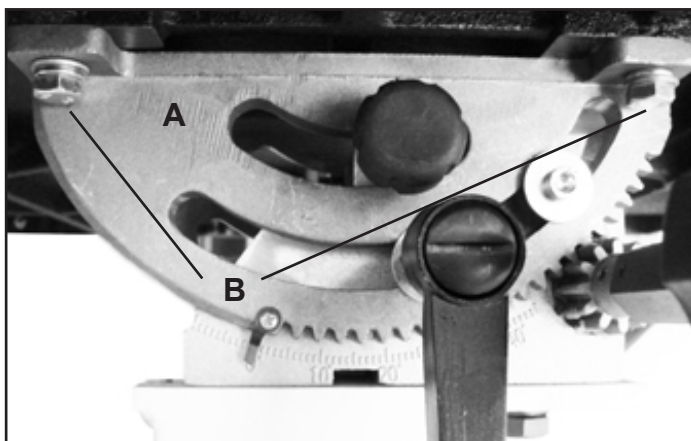

FIG. 6

Continued on page 12

ASSEMBLY

Work Table Assembly - continued

Installing Table Leveling Bar:

If the table leveling bar has not been pre-installed, follow the steps below for installation.

1. Locate the table leveling bar, two hex socket screws and two washers (#60B, 61B, 63B). FIG. 7 Inset, A.

2. Insert a hex socket screw and washer through the left hole of the table leveling bar and then into the threaded hole under the table's front edge, on the left side of the blade slot. FIG. 7, B.

3. Insert the second socket screw and washer into the threaded hole on the right side of the blade slot. Make sure that the opening of the slot on the right side of the table leveling bar faces back towards the table trunnion. This will allow the table leveling bar to pivot and open outward/forward from the bandsaw table when loosened.

RIP FENCE ASSEMBLY

1. With a 13mm wrench, remove one hex nut and flat washer from each stud on the fence bar (#14B, 15B). FIG. 8, A.

Leave one each of 13mm hex nut and washer on each stud on the fence bar. The remaining nut and washer will be used for drift adjustments that will be described later in this manual.

2. Next, install the fence bar studs into the table's front edge two pre-bored holes. Locate the 13mm hex nuts and washers removed in step 1 and install them on the opposite ends of each fence bar stud. **NOTE:** It may be necessary to open the table leveling bar to gain access to the right side fence bar stud.

HAND WHEEL INSTALLATION

There are two hand wheels used on the 10-370 Wood/Metal Bandsaw. The first controls the height of the upper guide post, the second controls the tension on the drive belt.

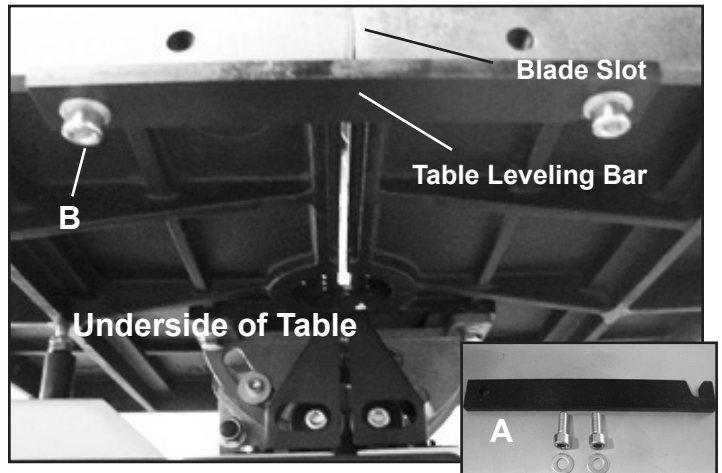
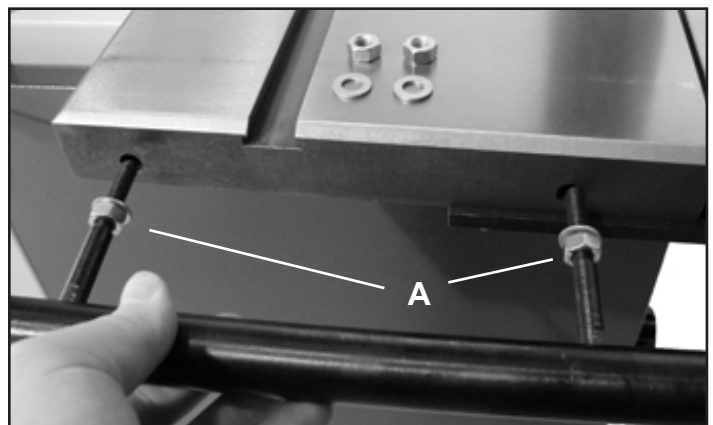

FIG. 7



NOTE: Scale (#66B) not shown on table front lip for clarity.

FIG. 8



FIG. 9

1. Attach the first hand wheel (#27C) to the rack and pinion shaft on the upper part of the bandsaw, with the 5mm "L" wrench. FIG. 9.

2. Then, attach the second crank handle (#21E) to the belt and speed control rod located on the bottom part of the saw, below the 4" dust port.

ASSEMBLY

TOOL STORAGE

Storage for the “L” hex wrenches is provided for quick access when adjustments are needed. Mount the tool holder onto the rear column with the two screws provided (#40A, 41A). Place the (4) hex wrenches (3, 4, 5 and 6mm) in the tool holder on the rear column support. FIG. 10.

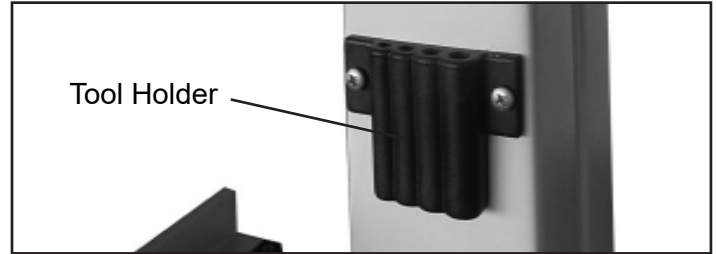

FIG. 10

ADJUSTMENTS

SETTING THE TABLE SQUARE TO THE SAW BLADE

1. The table may be set at 90° to the saw blade sides by adjusting the table stop screw under the table - installed on page 11. The table stop screw rests on the top of the quick release adjustment stop (C). By loosening the locking nut (A) and then adjusting the screw (B), the table can be set correctly. Retighten the locking nut to make sure that the 90° setting is maintained. FIG. 11.

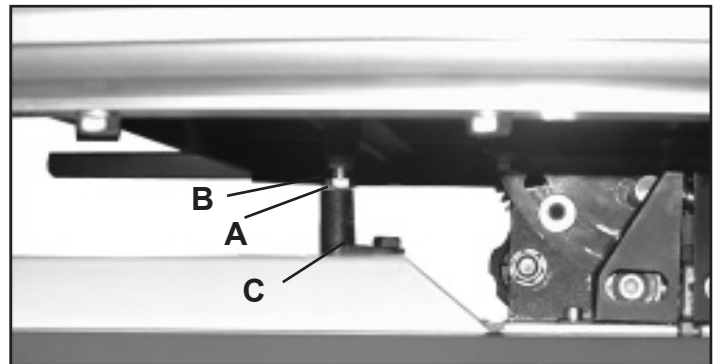

FIG. 11

2. The table may also be set at 90° to the back of the saw blade by adjusting the four trunnion micro adjustment screws, FIG. 12, A. First, slightly loosen the 2 bolts (#73B) that fasten the trunnion to the frame. Using the 3mm hex wrench, turn the applicable trunnion micro adjusting screws (#24B). Turning the screws clockwise will raise the trunnion; turning them counterclockwise will lower. Check table for 90° and one set, retighten the bolts (#73B).

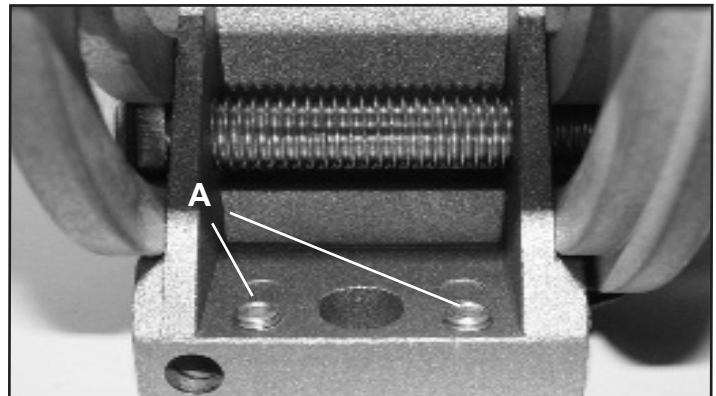

FIG. 12

NOTE: FIG. 12, the trunnion has been removed from bandsaw for clarity. Micro adjusting screws are raised to exaggerate location. Only two of the four micro adjusting screws are shown.

TILTING THE TABLE

Loosen the rear lock handle (#7B, FIG. 13, A) on the table trunnion. Turn the table tilting knob (#51B, B) to adjust the table to the desired angle. Use the angle indicator scale on the trunnion bracket to find the desired angle. Retighten the lock handle to secure the table in place.

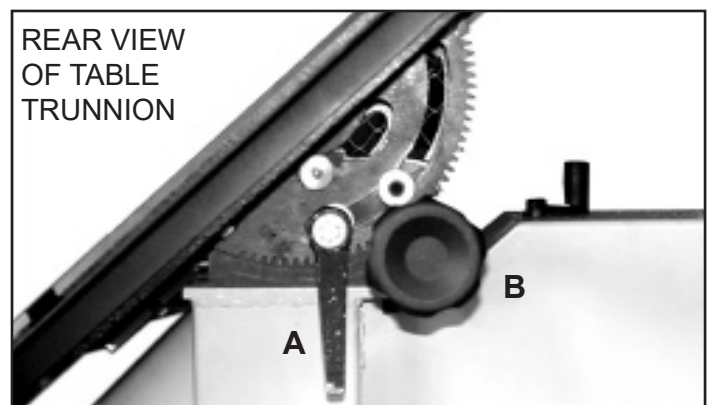

FIG. 13

ADJUSTMENTS

TRACKING THE SAW BLADE

Warning! Unplug the bandsaw. Adjust the upper and lower blade guides away from the blade so that they do not interfere with the blade movement in this process.

Open both doors. Loosen the rear lock lever (#21D, FIG. 14, A) by turning it counter clockwise. Turn the blade tracking knob (#24D, B) clockwise/counterclockwise while turning the upper wheel by hand at least three rotations until the blade tracks centered on the wheels. Finally, tighten the lock lever and close the doors.

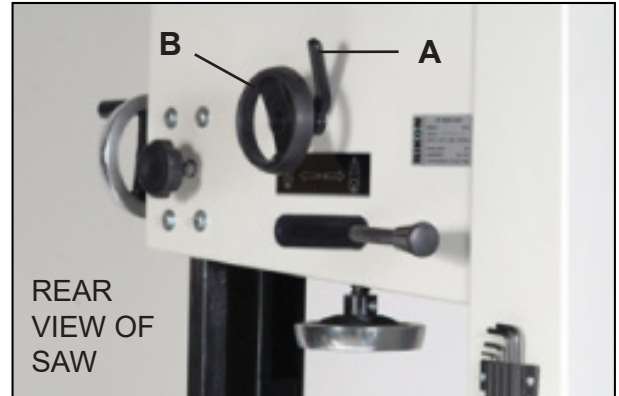

FIG. 14

ADJUSTING THE BLADE TENSION

The 10-370 has a quick release blade function which allows for fast blade changing and tensioning. The quick release lever extends from the rear of the saw. FIG. 15.

To *LOOSEN* the tension of the blade, turn the blade tension hand wheel (#15D, FIG. 16, A) counter-clockwise. To *TIGHTEN* the tension of the blade, turn the blade tension hand wheel clockwise.

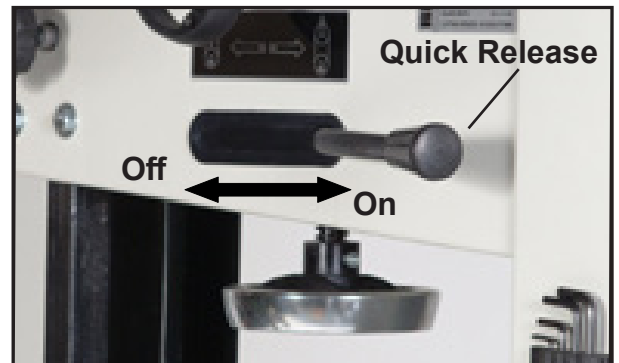

FIG. 15

Tension the blade until the tension readings correspond to the width of blade you are using by viewing through the tension indicator window (#9A, FIG. 16, B).

NOTE: The blade tension scale may read differently due to blade steel thickness or cut specifications of the blade manufacturer. It might be necessary to increase/decrease tension up/down one size on blade tension scale to achieve proper blade tension.

Caution! Always tension the blade with the quick release lever in the "On" position, with the lever positioned towards the saw column. Failure to do so could result in lack of blade tension or tension failure.

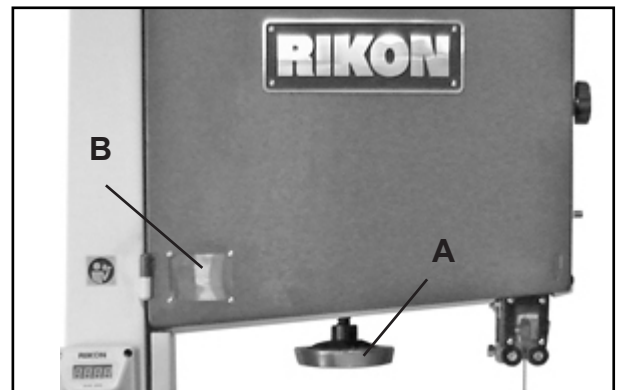

FIG. 16

BLADE TENSION INDICATOR

The blade tension indicator can be adjusted for blades that are of different steel thicknesses or cut over/under length by different manufacturers. With moderate tension on the blade, loosen the two adjusting screws with a Phillips-head screw driver (FIG. 17, A). Move the blade indicator bracket up/down as needed (B) to adjust the indicator's position on the scale, and then re-tighten the two adjusting screws when the setting is correct.

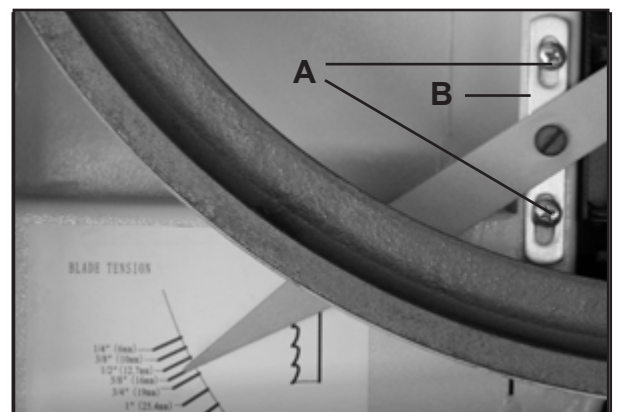

FIG. 17

ADJUSTMENTS

CHANGING THE SAW BLADE

1. Open the top and bottom wheel doors by turning the door locking knobs (#12A). FIG. 18, A.
2. Release the blade tension by moving the quick release lever from right to left. FIG. 15.
3. Open the hinged door on the blade guard by loosening the hex screw (#3C, FIG. 19, A).
4. Loosen the hex screws (#61B) under the front of the table, then slide open the right side of the table leveling bar (#60B). FIG. 20, A.
5. Remove the saw blade by feeding it through the slot in the table (FIG. 20, B), fence scale (not shown), upper and lower blade guides, and through the slot in the column/spine of the machine.

CAUTION Be careful not to cut yourself on the sharp saw teeth. Wear gloves for protection.

6. Install the new blade by reversing the process in step 5. Center the blade on both wheels. When installing the new blade, ensure that the blade teeth are pointing downwards and towards you at the position where the blade passes through the table.
7. Re-tension the new blade by moving the quick release lever from left to right, and check the blade tracking. Spin the upper wheel clockwise three times. The blade should run in the center of both wheels. Refer to page 14 for more details.
8. Set the saw blade tension as described on page 14.
9. Set the blade guides to the sides and rear of the saw blade as described on page 16 and 23.
10. Reverse steps 4 to 1 above, to prepare the saw for use before reconnecting the power supply.

WARNING: THE MACHINE MUST NOT BE PLUGGED IN AND THE POWER SWITCH MUST BE IN THE OFF POSITION UNTIL ALL ADJUSTMENTS ARE COMPLETE.

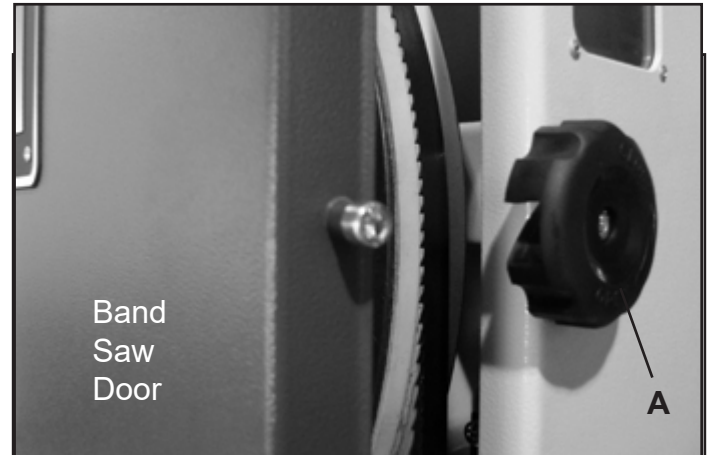

FIG. 18

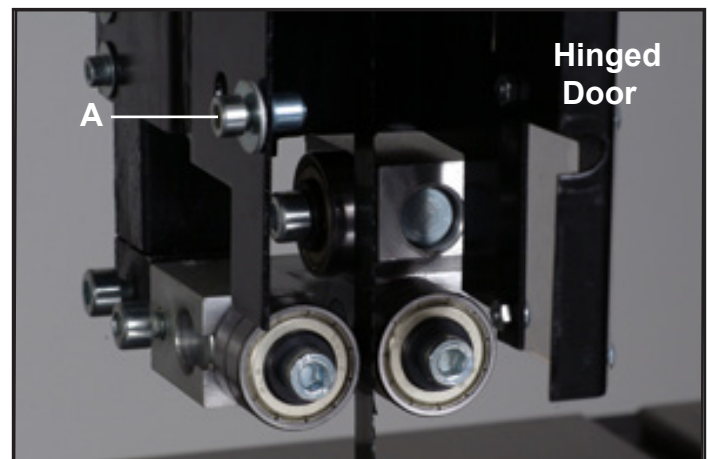
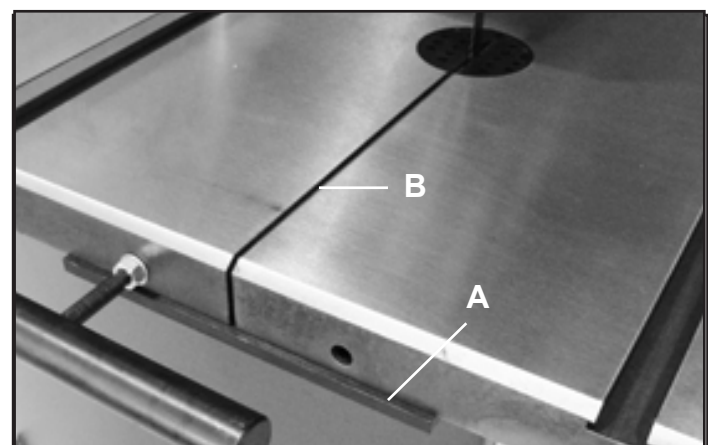

FIG. 19



NOTE: Scale (#66B) not shown on table front lip for clarity.

FIG. 20

ADJUSTMENTS

ADJUSTING THE BLADE GUIDES

Upper Guides:

1. Position the roller guides relative to the blade by loosening the locking hex screw (#42C, FIG. 21, A) and moving the guide carrier until the roller guides are approximately 1/16" behind the gullets of the bandsaw blade, then tighten the hex nut to set the bearings in place.
2. Set the roller guides to within 1/32" of the blade by releasing the front hex screw (#4C, B) on each side of the blade. Do not set the guides too close, as this will adversely affect the life of the bearings if they constantly turn.
3. Finally, adjust the rear thrust bearing to be just clear of the back of the blade by unlocking the hex nut (#9C, C) and moving the bearing.

Lower Guides:

1. Loosen the hex nut (#74B, FIG. 22, D), then move the lower guide carrier casting to allow the front bearings to be approximately 1/16" behind the gullets of the bandsaw blade, and tighten the hex nut to set the bearings in place.
2. Set the roller guides to within 1/32" of the blade sides by releasing the front bearing screw (#69B, E) and moving the bearings. Do not set the guides too close, as this will adversely affect the life of the bearings if they constantly turn.
3. Adjust the rear thrust bearing to be just clear of the back of the blade by unlocking the hex nut

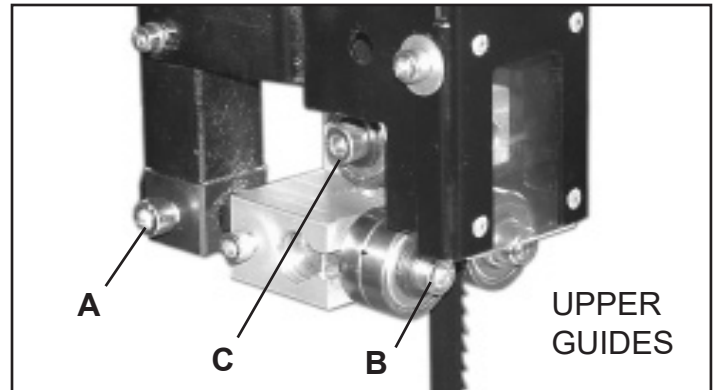

FIG. 21

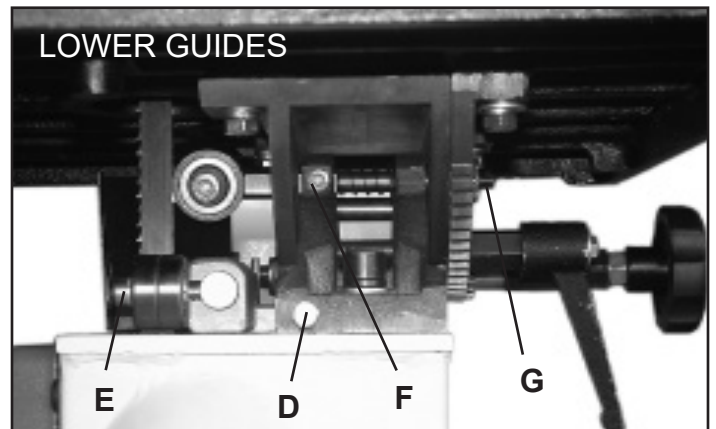

FIG. 22

(#75B, F), and turning the adjusting knob (G). When the bearing is positioned, tighten the nut.

Close the doors, then turn the bandsaw on and inspect that the upper, lower and thrust bearings are not turning. All bearings should not turn unless pressure from the work piece is applied to the blade. If bearings are turning under no pressure, repeat the steps above to properly adjust the blade guides.

ADJUSTING THE GUIDE POST

Loosen the guidepost lock knob (#24C, FIG. 23, A) and turn the guidepost handwheel (#27C, B) to raise or lower the guide post/ upper blade guide assembly to the desired height above your work piece. Then tighten the guidepost lock knob to secure the upper blade guides in place.

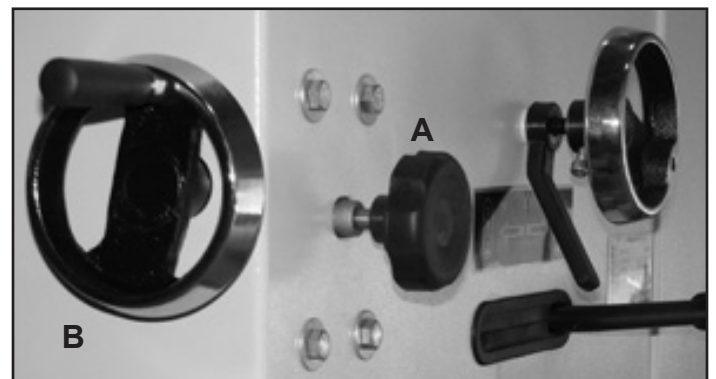

FIG. 23

ADJUSTMENTS

Continued from page 16

NOTE: The bottom edge of the guide bearings should be approximately 1/4" above the top surface of the work piece. FIG. 24.

CHANGING THE BLADE SPEED PULLEY SETTINGS

The 10-370 has two pulley speed ranges;

- Low Speed - 82-1312 ft/min
- High Speed - 328-3280 ft/min

The lower bandsaw wheel and the motor shaft have twin, multi-vee form pulleys for running the bandsaw blade at a low or high speed. FIG. 25.

The V-belt (B) passes around the wheel pulley (C), the belt tension pulley (D), and then the motor pulley (A). The belt tension is released and applied by using the hand wheel (E), which moves the tension pulley back and forth.

For the *high speed* (328-3280 ft/min) the belt should be fitted to the rear pulley on both the motor and the wheel. FIG. 26, H.

For the *low speed* (82-1312 ft/min), the belt should be fitted to the front pulley on both the motor and wheel. FIG. 26, L.

SETTING THE DRIVE BELT TENSION

To properly adjust belt tension, turn the hand wheel (#21E, FIG. 25, E) until there is approximately 3/8" - 1/2" deflection in the V-belt. FIG. 27.

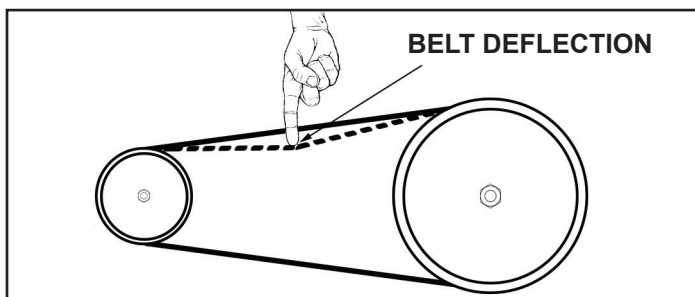

FIG. 27

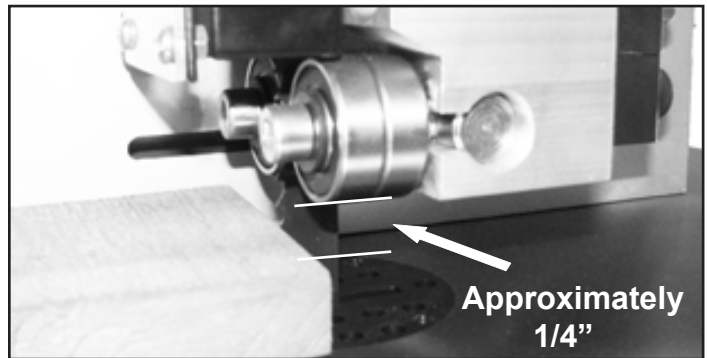

FIG. 24

⚠ WARNING: THE MACHINE MUST NOT BE PLUGGED IN AND THE POWER SWITCH MUST BE IN THE OFF POSITION UNTIL ALL ADJUSTMENTS ARE COMPLETE.

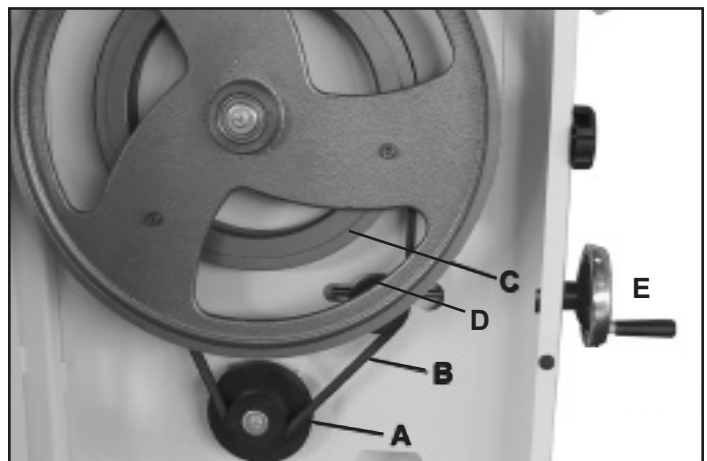

FIG. 25

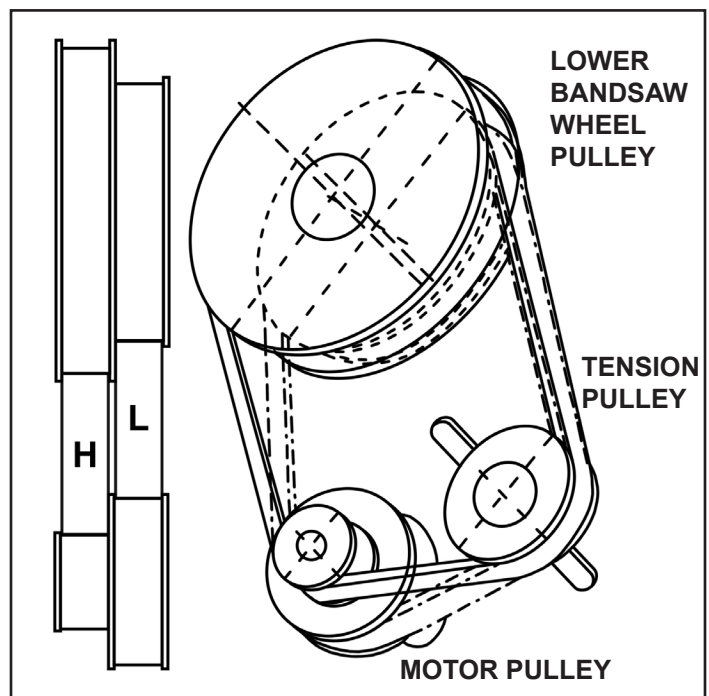

FIG. 26

ADJUSTMENTS

VARIABLE SPEED SWITCH

In conjunction with the two speed pulley system, the 10-370 Wood/Metal bandsaw also features a variable speed switch. To use with in a specific belt speed range, simply turn the bandsaw on (FIG. 28, A) and rotate the variable speed dial (B) clockwise to increase the speed, and counter clockwise to decrease the speed. The blade speed will be indicated on the digital readout display (C). To stop the bandsaw press the large red button (D).

NOTE: The variable speed dial will only increase speed to the highest speed shown depending on belt position. See page 17.

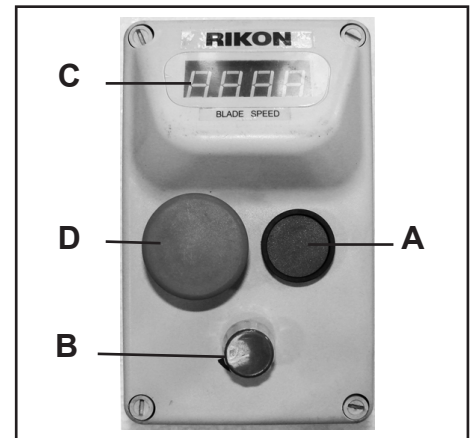

FIG. 28

ADJUSTING THE RIP FENCE / DRIFT

Align the fence assembly until it is parallel with the side of the blade and miter gauge slot by adjusting the fence bar nuts accordingly (#15B, FIG. 29, A). Repositioning these nuts on the support shafts (#13B) will angle the fence right or left on the table. Once the fence is properly aligned, make sure that the nuts are secure. The same adjustment can be made to compensate for blade drift.

Check that the fence is 90 degrees to the table using a suitable square. If no adjustments are needed, fully tighten the fence bar nuts. If adjustment is required, raise or lower either side of the fence rail until the fence body is 90 degree to the table. Once set at 90 degrees, fully tighten the fence bar nuts.

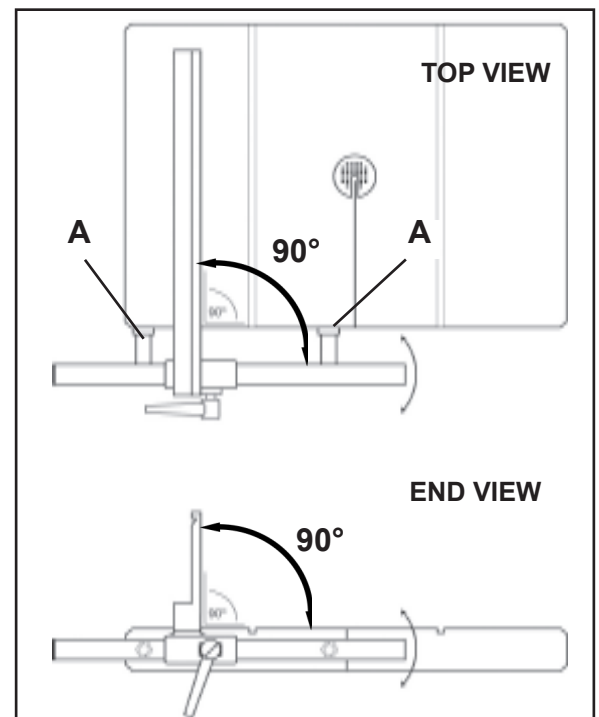

FIG. 29

RE-SAWING

A re-saw guide bar is supplied to help correct any blade wandering during certain re-sawing operations.

For re-sawing, attach the re-saw bar (#12B) to the slot on the fence. Position the re-saw bar so that it is aligned with the front of the blade. Draw a reference line down the workpiece. Use the bar as a pivot point, angling the wood left or right while against the bar, to follow the line through the cut. FIG. 30.

Note: The re-saw bar is not needed for all re-saw operations. Proper blade tension and selection, as well as proper guide set up, will allow re-sawing flat stock against the fence without the use of the re-saw bar.

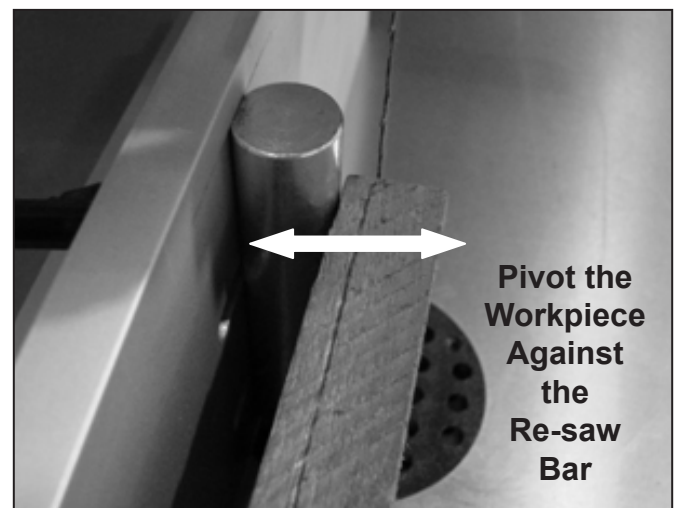

FIG. 30

OPERATION

BASIC OPERATION

The bandsaw blade cuts on a continuous down-stroke through the table. Never start the saw with the work piece in contact with the saw blade.

With both hands, firmly hold the work piece down on the table, and feed it slowly towards the blade, putting only light pressure on it, and keeping your hands away from the blade.

Keep your hands/fingers away from the blade. Use a push stick whenever working close to the blade.

For best results, the blade must be sharp. A dull blade will not cut correctly, especially when straight cutting, and causes excess pressure to be applied on the rear guide bearings.

Select the right blade for the job, depending on the thickness of the wood and the cut to be made. The thinner and harder the wood, the finer the teeth of the blade should be. Use a fine tooth blade for cutting sharp curves. See page 36 for more information on blades.

The bandsaw is especially suited for cutting curves, but will also make straight cuts. When cutting, follow the design marked out by pushing and turning the workpiece evenly into the blade. Do not attempt to turn the workpiece without pushing it, as this may cause the workpiece to get stuck, or bend the blade. For straight cuts, use the fence provided to feed the workpiece along the blade slowly and in a straight line. Use a miter gauge for cross-cut or angle cutting.

METAL CUTTING

Warning! The 10-370 Wood/Metal bandsaw is designed for DRY CUTTING ONLY. Do not use lubricants or coolants with this bandsaw.

Proper blade selection for the material to be cut is key to good performance. Do not force the material into the blade as excessive heat will lead to premature blade failure. Poor cutting results will also occur. Always keep three teeth in the material being cut.

Stack or bundle cutting is not recommended with this bandsaw. When cutting round stock, use jigs or wedges to prevent the material from rolling into the cut.

Blade speed differs for each type or grade of metal to be cut. Below is a chart of common materials and the suggested blade speeds. The speeds shown have been reduced by 30% for dry cutting operations. It may be necessary to reduce an additional 15% due to material hardness. Changing blade type/style will also help performance.

NOTE: Blade speed and performance depend on proper blade selection. Consult your blade manufacturer for the proper blade style and speed required for the material to be cut.

METAL TYPE	BLADE SPEED -Ft/Min
Brass Alloys	140-154
Bronze Alloys	80-230
Cast Iron	80-157
Copper Alloys	112-206
Cr-Mo Alloy	136-164
Low/Med Carbon Steel	161-189
Stainless Steel	80-95

OPERATION

Cutting Plastic/Composite Material

The 10-370 Wood/Metal bandsaw is also designed for cutting plastics and composite materials.

As always, selecting the proper blade for the material to be cut is key to getting good performance. Do not force the material into the blade as excessive heat will lead to premature blade failure and poor cutting results will also occur.

Stack or bundle cutting is recommended if the material is properly secured during the cut. When cutting round stock, use jigs or wedges to prevent the material from rolling into the cut.

Blade speed differs for each type of material to be cut. Improper blade selection and speed may result in melting or curling the material. Changing blade type/style will also help performance.

NOTE: Blade speed and performance depend on proper blade selection. Consult your blade manufacturer for the proper blade and speed required for the material to be cut.

WIRING DIAGRAM

WARNING! This machine must be grounded. Replacement of the power supply cable should only be done by a qualified electrician. See page 5 for additional electrical information.

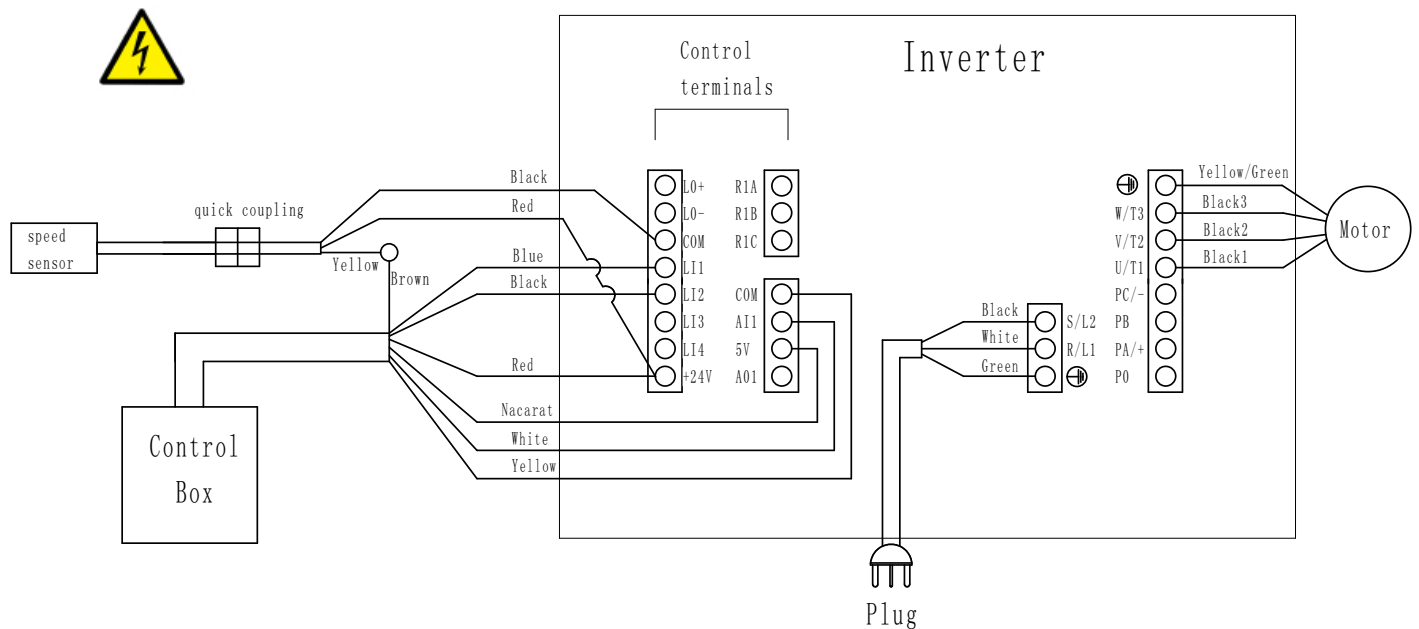

TROUBLESHOOTING

⚠ WARNING: FOR YOUR OWN SAFETY, ALWAYS TURN OFF AND UNPLUG THE MACHINE BEFORE CARRYING OUT ANY TROUBLESHOOTING OR ADJUSTMENTS.

TROUBLE	PROBABLE CAUSE	REMEDY
The machine does not work when switched on.	<ol style="list-style-type: none"> 1. No power supply. 2. Defective switch. 	<p>Check the cable for breakage. Contact your local dealer for repair.</p>
The blade does not move with the motor running.	<ol style="list-style-type: none"> 1. The quick release lever or blade tension handwheel has not been tightened. 2. The blade has come off one of the wheels. 3. The saw blade has broken. 4. The drive belt has snapped. 	<p>Switch off the motor, tighten the quick release lever or blade tension handwheel.</p> <p>Open the hinged door and check.</p> <p>Replace the blade. Replace the belt.</p>
The blade does not cut in a straight line.	<ol style="list-style-type: none"> 1. Fence for cutting not used. 2. Too fast feed rate. 3. The blade teeth are dull or damaged. 4. Blade guides not suitably adjusted. 	<p>Use a fence. Put light pressure on the workpiece & make sure the blade does not bend. Use a new blade.</p> <p>Adjust the blade guides (see the section on page 16 and 23).</p>
The blade does not cut, or cuts very slowly.	<ol style="list-style-type: none"> 1. The teeth are dull, caused by cutting hard material or long use. 2. The blade was mounted in the wrong direction. 	<p>Replace the blade, use a 6 T.P.I. blade for wood and soft materials. Use a 14 T.P.I. blade for harder materials. A 14 T.P.I. blade always cuts slower due to the finer teeth and the slower cutting performance.</p> <p>Fit the blade correctly.</p>
Sawdust builds up inside the machine.	<ol style="list-style-type: none"> 1. This is normal 	<p>Clean the machine regularly. Open the hinged door and remove the sawdust with a vacuum cleaner.</p>
Sawdust inside the motor housing.	<ol style="list-style-type: none"> 1. Excessive dust build-up on the machine exterior components. 	<p>Clean the ventilating slots of the motor with a vacuum cleaner. From time to time remove the sawdust to prevent it from being sucked into the housing</p>
The machine does not cut at 45° or 90° angles.	<ol style="list-style-type: none"> 1. The table is not at right angles to the blade. 2. The blade is dull or too much pressure was put on the workpiece. 	<p>Adjust the table.</p> <p>Replace the blade or put less pressure on the workpiece.</p>
The blade cannot be properly positioned on the bandwheels.	<ol style="list-style-type: none"> 1. The wheels are not in alignment. Defective bearing. 2. The blade tracking hasn't been properly adjusted. 3. Inferior blade. 	<p>See pages 24 and 25 for wheel alignment. Contact RIKON Technical Support.</p> <p>Adjust the blade tracking (see pages 14, 24 and 25). Replace the blade.</p>

For parts or technical questions contact: techsupport@rikontools.com or 877-884-5167.

TROUBLESHOOTING

⚠ WARNING: THE MACHINE MUST NOT BE PLUGGED IN AND THE POWER SWITCH MUST BE IN THE OFF POSITION UNTIL ALL ADJUSTMENTS ARE COMPLETE.

ADJUSTING THE UPPER GUIDE BEARINGS PARALLEL TO THE BLADE

The guide bearing assembly is factory pre-set. If adjustment is needed, follow the steps below.

Refer to “Guide Post Assembly” parts diagram on page 30.

1. Slightly loosen the four Hex Screws (#23C) on the rear of the upper bandsaw housing. This will allow you to adjust the four Set Screws (#33C) in the Guide Bracket (#21C).
2. With the top door open, lower the Guide Post Assembly (#30C) so you can access the Set Screws.
3. Place a 3mm “L” wrench through one of the holes in the Cover (#16C).
 - Turning the two left set screws clockwise will adjust the left bearings to the right.
 - Turning the two right set screws clockwise will adjust the right bearings to the left.Check the bearings for parallel settings to the blade, and re-adjust as necessary.
4. Re-tighten the four Hex Screws on the housing. Repeat steps if the bearings are still not parallel.

ADJUSTING THE UPPER GUIDE BEARINGS TO TRACK CLOSE TO THE BLADE

If the upper guide bearings do not adjust to within 1/32” of the blade after the normal blade guide adjustments are done (see page 16), then Guide Post (#30C) may need adjustment.

Refer to “Guide Post Assembly” parts diagram on page 30.

1. Lower the Guide Post (#30C) all the way to the table.
2. Slightly loosen the four Hex Screws (#23C) on the rear of the upper bandsaw housing.
3. Shift the upper guide post right or left until bearings are properly spaced on each side of blade.
4. Raise the Guide Post seven inches off the table and check alignment. If side guide bearings travel out of alignment repeat steps above. Raise the Guide Post to the top of the travel and check final alignment. Repeat steps above if necessary.
5. Re-tighten the four Hex Screws on the upper housing rear when the alignments are completed.

CHANGING BANDSAW TIRES

Use a putty knife to get underneath the tire and pull it up and away from the wheel. Work the putty knife all the way around the wheel to loosen the tire. Then, use the putty knife as leverage to flip the tire over and off of the wheel. Clean the inside of the groove, removing any dirt, debris or cement with lacquer thinner.

Soak the replacement tire in warm water to make it more flexible. Dry the tire, and while it is still warm, lay it on top of the wheel. Start by setting the tire into the wheel groove at the top of the wheel. Using a putty knife, work the new tire around the wheel, making sure not to slice the tire. If rubber cement is to be used as a binder, make sure to distribute it evenly. Having high spots between the wheel and the tire will cause a vibration and effect blade tracking.

TROUBLESHOOTING

LOWER WHEEL ADJUSTMENTS

The following instructions will correct common blade issues related to the lower wheel's alignment in relation to the upper wheel. These adjustments will correct the blade position on the lower wheel and blade oscillation (wobble). These are critical adjustments which affect the performance and accuracy of the bandsaw.

CAUTION PLEASE READ AND UNDERSTAND THESE STEPS THOROUGHLY BEFORE MAKING ANY ADJUSTMENTS. FAILURE TO DO SO COULD DAMAGE THE MACHINE.

Please contact a tech support representative if you have questions before attempting these adjustments. RIKON Tech Support at 877-884-5167 or techsupport@rikontools.com

Release the blade tension completely before making any lower wheel adjustments. Pressure must be released on the lower wheel to allow proper adjustments and to avoid damaging the machine.

If the blade is not running true, or it is not running on center of the lower wheel but is correct on the upper wheel, then an adjustment to the wheel hub on the rear of the bandsaw is required.

The numbers shown on the rear hub photo represent the positions on a clock face.

NOTE: To help identify the extent of rotation on a bolt, mark a black dot on the edge of the bolt as a visual indicator.

If a blade is tracking forward on the lower wheel toward the door, follow these correction steps:

- 1.) De-tension the saw blade.
- 2.) Loosen 9 o'clock shaft bolt to take pressure off the shaft.
- 3.) Loosen 12 o'clock shaft bolt one half rotation.
- 4.) Tighten the 6 o'clock shaft bolt until the shaft touches the 12 o'clock adjusting bolt.
- 5.) Lock all three shaft bolts.
- 6.) Re-tension the saw blade and set the upper wheel to plumb by adjusting the tracking knob. Spin the upper wheel by hand and track the blade.
- 7.) Repeat if further adjustment is necessary.

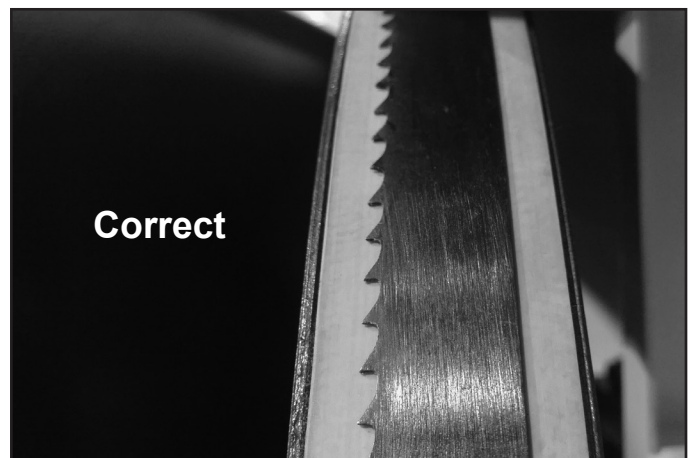
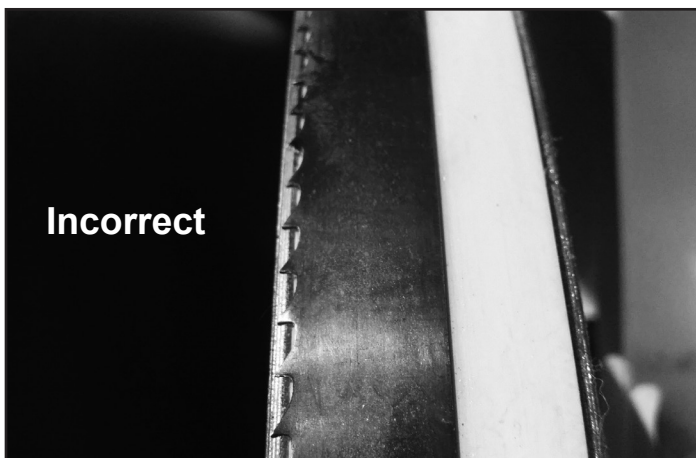
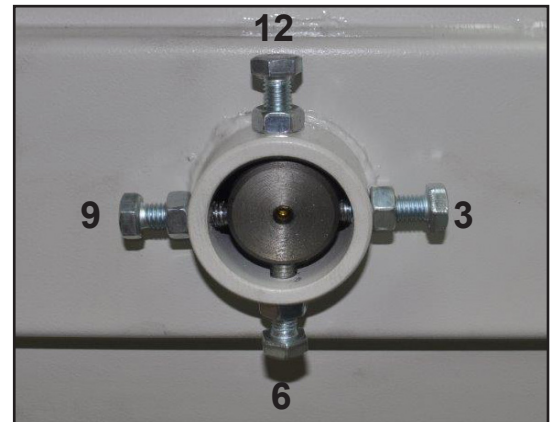

TROUBLESHOOTING

If a blade is tracking on the rear of the lower wheel, away from the door, follow these steps:

- 1.) De-tension the saw blade.
- 2.) Loosen 9 o'clock shaft bolt to take pressure off the shaft.
- 3.) Loosen 6 o'clock shaft bolt one half rotation.
- 4.) Tighten the 12 o'clock shaft bolt until the shaft touches the 6 o'clock adjusting bolt.
- 5.) Lock all three shaft bolts.
- 6.) Re-tension the saw blade and set the upper wheel to plumb by adjusting the tracking knob. Spin the upper wheel by hand and track the blade.
- 7.) Repeat if further adjustment is necessary.

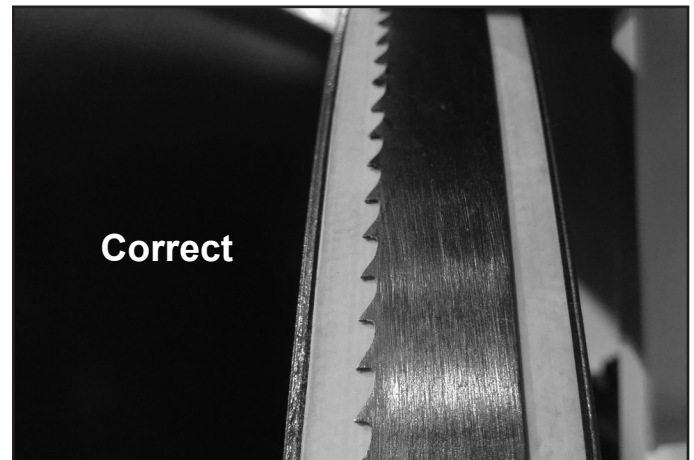
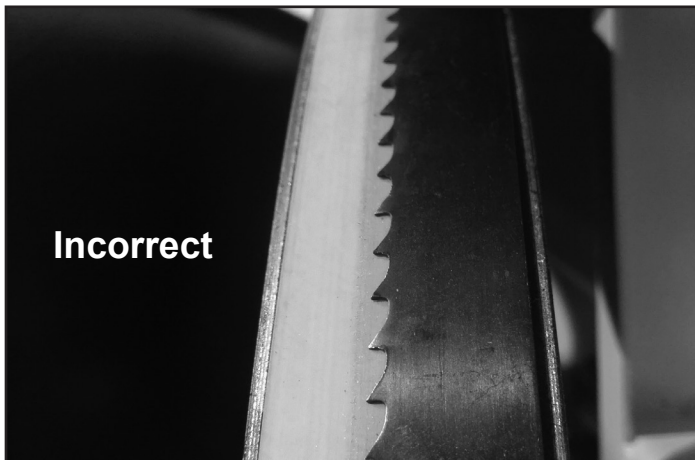

If a blade is moving back and forth (wobbling), follow these steps:

First, check the bandsaw blade to insure that it has been welded correctly, so that the blade's back is in proper alignment - flat (if it is laid down on a table surface).

If the blade is welded true, then adjustment to the wheel hub on the rear of the bandsaw is required.

- 1.) De-tension the saw blade.
- 2.) Loosen 6 o'clock shaft bolt to take pressure off of the shaft.
- 3.) Loosen 9 o'clock shaft bolt one half rotation.
- 4.) Tighten the 3 o'clock shaft bolt until the shaft touches the 9 o'clock adjusting bolt.
- 5.) Lock all three shaft bolts.
- 6.) Re-tension the saw blade and set the upper wheel to plumb by adjusting the tracking knob. Spin the upper wheel by hand and track the blade.
- 7.) Start the bandsaw and check blade movement.
- 8.) If movement has diminished then continue with the adjustment.
- 9.) If movement is worse, reverse the adjustments in steps 3 and 4.

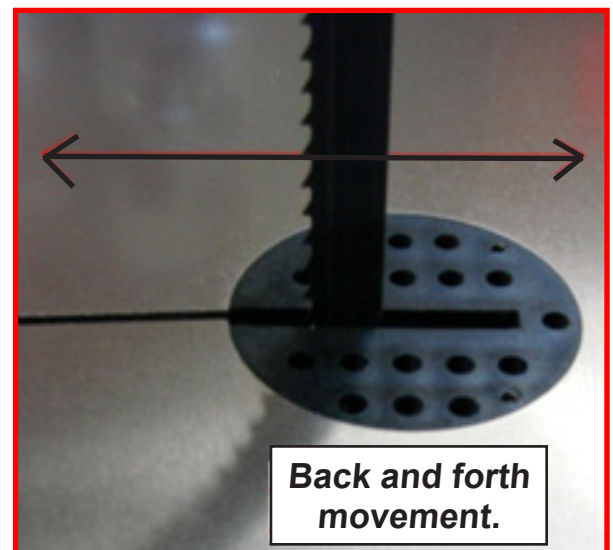

PARTS DIAGRAM

FRAME ASSEMBLY (A)

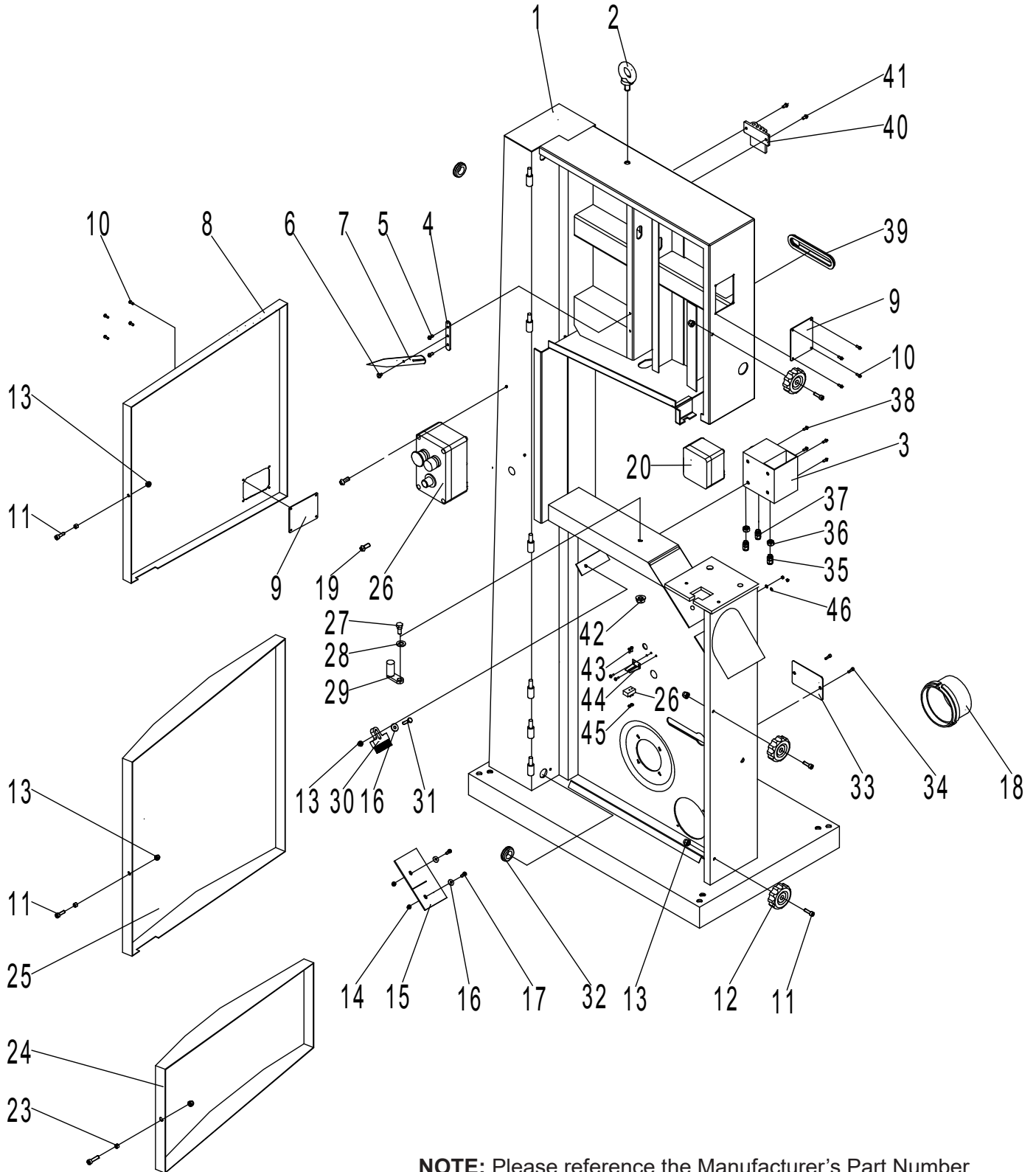

NOTE: Please reference the Manufacturer's Part Number when calling for Replacement Parts.

For Parts under Warranty, the serial number of your machine is required.

PARTS LIST

FRAME ASSEMBLY (A)

KEY NO.	DESCRIPTION	MFG. PART NO.	QTY.
1A	Frame	P10-370-1A	1
2A	Lifting bolt	P10-370-2A	1
3A	Inverter box	P10-370-3A	1
4A	Indicator adjustment plate	P10-370-4A	1
5A	Cross recess pan head screw M5X8	P10-370-5A	2
6A	Screw	P10-370-6A	1
7A	Blade tension indicator	P10-370-7A	1
8A	Upper wheel cover	P10-370-8A	1
9A	Plastic window	P10-370-9A	2
10A	Self-plugging rivet	P10-370-10A	8
11A	Hex socket cap screws M6X20	P10-370-11A	6
12A	Knob	P10-370-12A	3
13A	Self-locking nut M6	P10-370-13A	7
14A	Self-locking nut M6	P10-370-14A	2
15A	Dust board	P10-370-15A	1
16A	Big washer	P10-370-16A	3
17A	Screw M6X16	P10-370-17A	2
18A	Dust port	P10-370-18A	1
19A	Hex socket cap screws M5X20	P10-370-19A	2
20A	Inverter	P10-370-20A	1
23A	Sleeve	P10-370-23A	3
24A	Small wheel cover	P10-370-24A	1
25A	Lower wheel cover	P10-370-25A	1
26A	Switch box assembly	P10-370-26A	1
27A	Shaft	P10-370-27A	1
28A	Wave washer	P10-370-28A	1
29A	Table level support	P10-370-29A	1
30A	Brush	P10-370-30A	1
31A	Hex bolt M6X25	P10-370-31A	1
32A	Rubber bushing	P10-370-32A	2
33A	Threading plate	P10-370-33A	1
34A	Hex socket cap screws M6X10	P10-370-34A	2
35A	Cord strain relief	P10-370-35A	2
36A	Nut	P10-370-36A	2
37A	Pull off	P10-370-37A	1
38A	Cross recess pan head screw M5X16	P10-370-38A	4
39A	Dust shield	P10-370-39A	1
40A	Tool holder	P10-370-40A	1
41A	Cross recess pan head screw M5X12	P10-370-41A	2
42A	Self-locking nut M8	P10-370-42A	1
43A	Cross recess pan head screw M4x10	P10-370-43A	4
44A	Support frame	P10-370-44A	1
45A	Nut	P10-370-45A	4
46A	Washer	P10-370-46A	2

PARTS DIAGRAM

TABLE ASSEMBLY (B)

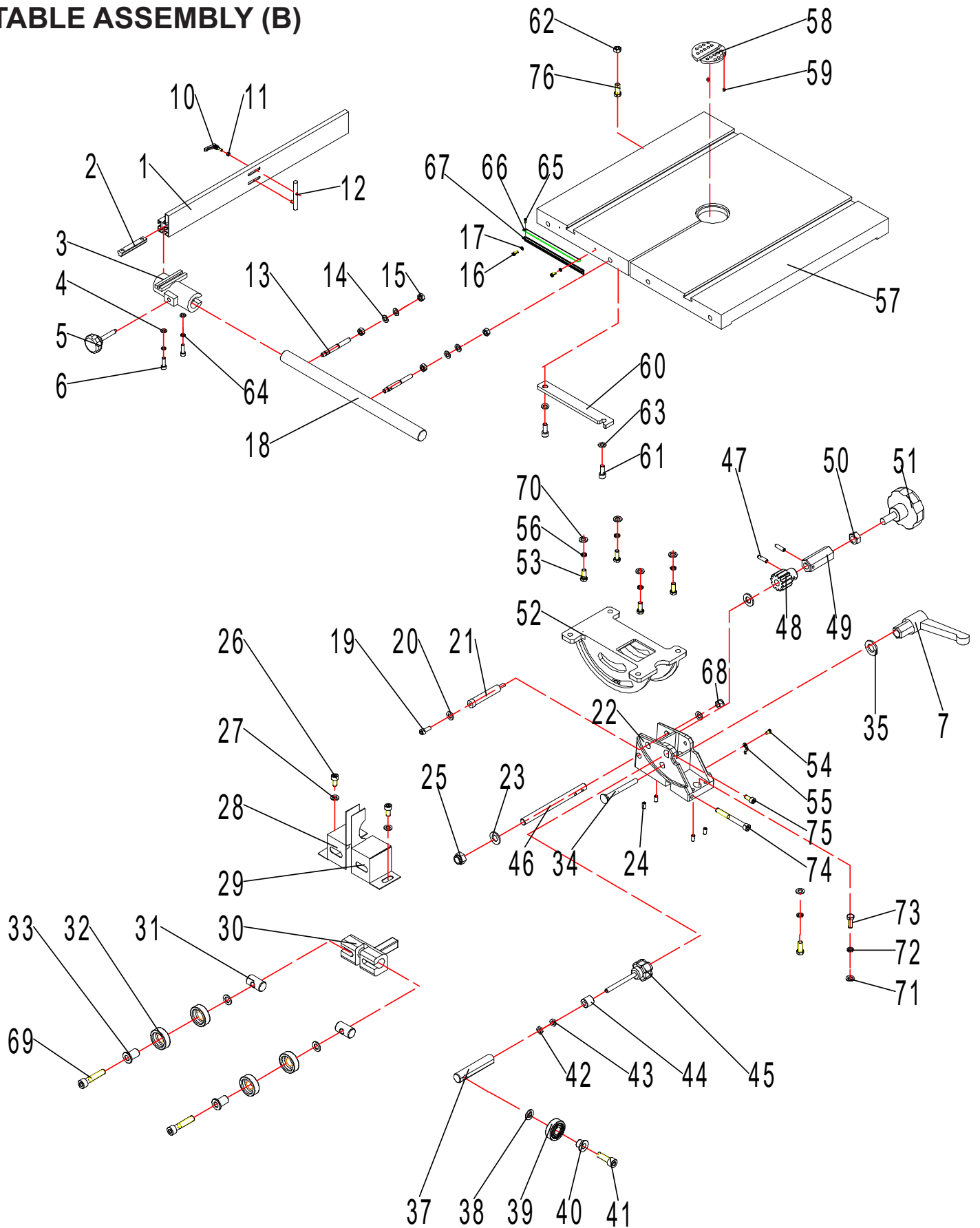

PARTS LIST

TABLE ASSEMBLY (B)

KEY NO.	DESCRIPTION	MFG. PART NO.	QTY.	KEY NO.	DESCRIPTION	MFG. PART NO.	QTY.
1B	Fence	P10-370-1B	1	41B	Hex screw M8X25	P10-370-41B	1
2B	Lock plate	P10-370-2B	1	42B	Thin nut M6	P10-370-42B	1
3B	Adjustable base	P10-370-3B	1	43B	Thin nut M6	P10-370-43B	1
4B	Flat washer	P10-370-4B	2	44B	Tube	P10-370-44B	1
5B	Handle	P10-370-5B	1	45B	Handle	P10-370-45B	1
6B	Screw M6X16	P10-370-6B	2	46B	Gear shaft	P10-370-46B	1
7B	Clamp handle M12X95	P10-370-7B	1	47B	Roll pin	P10-370-47B	2
10B	Handle M6X50X32	P10-370-10B	1	48B	Small gear	P10-370-48B	1
11B	Bushing	P10-370-11B	1	49B	Handle	P10-370-49B	1
12B	Re-Saw bar	P10-370-12B	1	50B	Nut M10	P10-370-50B	1
13B	Upper shaft	P10-370-13B	2	51B	Blade tracking handle	P10-370-51B	1
14B	Flat washer	P10-370-14B	4	52B	Table trunnion	P10-370-52B	1
15B	Nut M8	P10-370-15B	4	53B	Hex bolt M8X20	P10-370-53B	4
16B	Pan head screw M5X12	P10-370-16B	2	54B	Tapping screw	P10-370-54B	1
17B	Flat washer	P10-370-17B	2	55B	Pointer	P10-370-55B	1
18B	Fence bar	P10-370-18B	1	56B	Spring washer	P10-370-56B	4
19B	Hex cap screw M6X16	P10-370-19B	1	57B	Table	P10-370-57B	1
20B	Big washer	P10-370-20B	2	58B	Aluminum table insert	P10-370-58B	1
21B	Guide shaft	P10-370-21B	1	59B	Hex screw M6X4	P10-370-59B	2
22B	Lower table trunnion	P10-370-22B	1	60B	Mounting plate	P10-370-60B	1
23B	Flat washer	P10-370-23B	2	61B	Hex screw M8X16	P10-370-61B	2
24B	Hex screw M6X12	P10-370-24B	4	62B	Nut M8	P10-370-62B	1
25B	Hex lock nut M10	P10-370-25B	1	63B	Flat washer	P10-370-63B	2
26B	Hex cap screw M5X12	P10-370-26B	2	64B	Spring washer	P10-370-64B	2
27B	Flat washer	P10-370-27B	2	65B	Pan hd screw M4X8	P10-370-65B	2
28B	Left cover	P10-370-28B	1	66B	Scale	P10-370-66B	1
29B	Right cover	P10-370-29B	1	67B	Seat for scale	P10-370-67B	2
30B	Lower guide	P10-370-30B	1	68B	Self-locking nut M6	P10-370-68B	1
31B	Guide shaft	P10-370-31B	2	69B	Hex screw M8X40	P10-370-69B	2
32B	Bearing 6201	P10-370-32B	4	70B	Flat washer	P10-370-70B	4
33B	Tube	P10-370-33B	2	71B	Flat washer	P10-370-71B	2
34B	Bolt M12X90	P10-370-34B	1	72B	Spring washer	P10-370-72B	2
35B	Flat washer	P10-370-35B	1	73B	Bolt M12X30	P10-370-73B	2
37B	Bearing retainer	P10-370-37B	1	74B	Screw M6X50	P10-370-74B	1
38B	Flat washer	P10-370-38B	3	75B	Hex screw M6X10	P10-370-75B	1
39B	Bearing 6201	P10-370-39B	1	76B	Hex bolt M8X20	P10-370-76B	1
40B	Tube	P10-370-40B	1				

NOTE: Please reference the Manufacturer's Part Number when calling for Replacement Parts. For Parts under Warranty, the serial number of your machine is required.

PARTS DIAGRAM

GUIDE ASSEMBLY (C)

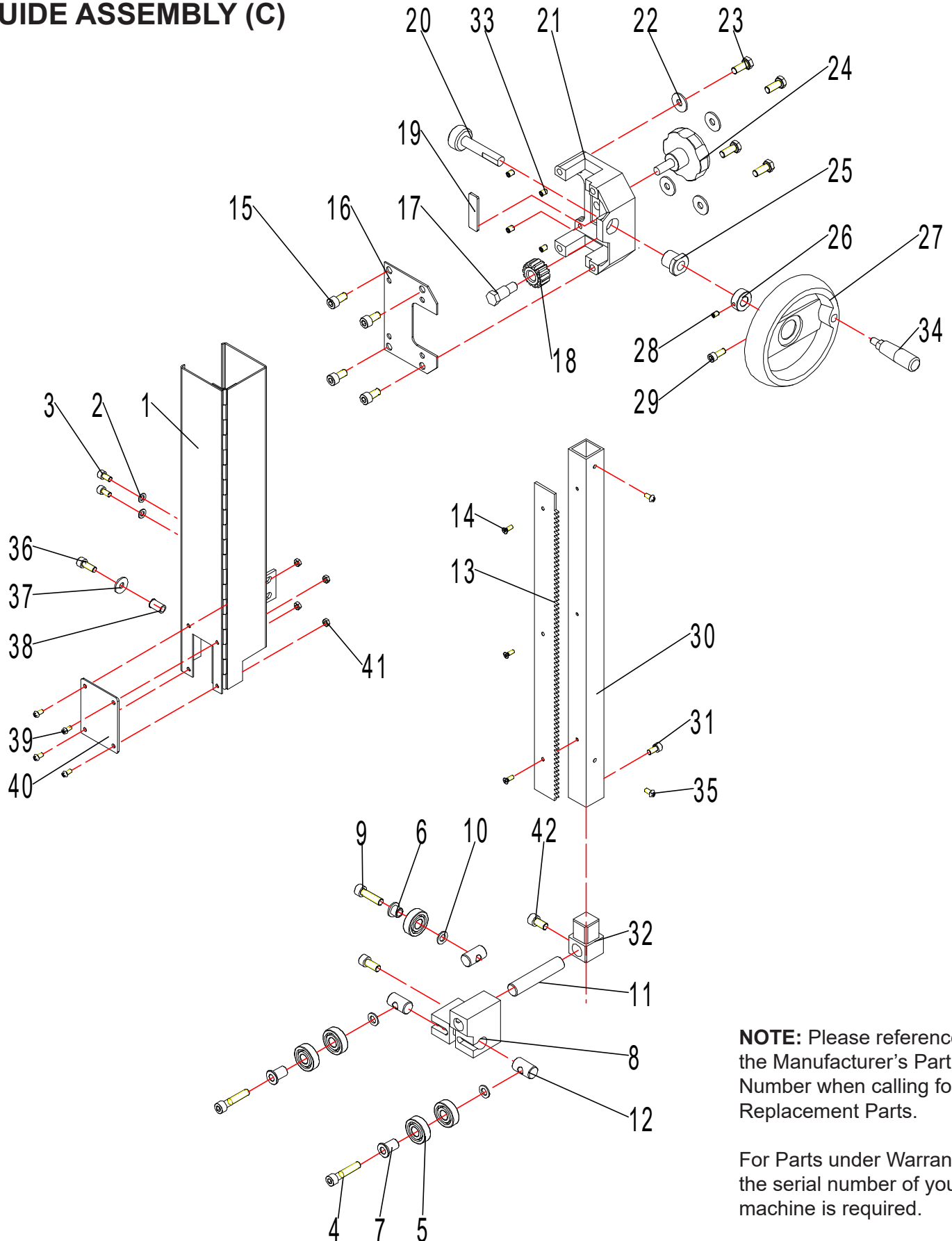

NOTE: Please reference the Manufacturer's Part Number when calling for Replacement Parts.

For Parts under Warranty, the serial number of your machine is required.

PARTS LIST

GUIDE ASSEMBLY C)

KEY NO.	DESCRIPTION	MFG. PART NO.	QTY.
1C	Blade guard assembly	P10-370-1C	1
2C	Flat washer	P10-370-2C	2
3C	Hex socket cap screws M5X12	P10-370-3C	2
4C	Hex socket cap screws M8X40	P10-370-4C	2
5C	Bearing 6201	P10-370-5C	5
6C	Tube	P10-370-6C	1
7C	Tube	P10-370-7C	2
8C	Upper guide body	P10-370-8C	1
9C	Hex socket cap screws M8X30	P10-370-9C	1
10C	Flat washer	P10-370-10C	3
11C	Adjusting bar	P10-370-11C	1
12C	Guide ring	P10-370-12C	3
13C	Rack	P10-370-13C	1
14C	Countersunk screw M4X10	P10-370-14C	3
15C	Hex socket cap screws M8X16	P10-370-15C	5
16C	Cover	P10-370-16C	1
17C	Fixed bolt	P10-370-17C	1
18C	Helical gear	P10-370-18C	1
19C	Fixed plate	P10-370-19C	1
20C	Worm cylinder	P10-370-20C	1
21C	Guide bracket	P10-370-21C	1
22C	Big washer	P10-370-22C	4
23C	Hex bolt M8X16	P10-370-23C	4
24C	Table tilting knob	P10-370-24C	1
25C	Bushing	P10-370-25C	1
26C	Retaining ring	P10-370-26C	1
27C	Small hand wheel	P10-370-27C	1
28C	Screw M5X8	P10-370-28C	1
29C	Hex socket cap screws M6X20	P10-370-29C	1
30C	Upper guide post	P10-370-30C	1
31C	Hex socket cap screws M6X12	P10-370-31C	1
32C	Guide support block	P10-370-32C	1
33C	Socket head cap screw M6X12	P10-370-33C	4
34C	Hand wheel handle	P10-370-34C	1
35C	Cross recess pan head screw M5X10	P10-370-35C	2
36C	Screw M6X16	P10-370-36C	1
37C	Big washer	P10-370-37C	1
38C	Countersunk head nut M6X15	P10-370-38C	1
39C	Cross recess pan head screw M4X8	P10-370-39C	4
40C	Inspection cap	P10-370-40C	1
41C	Nut M4	P10-370-41C	4
42C	Screw M8X12	P10-370-42C	1

PARTS DIAGRAM

BLADE TENSION & TRACKING (D)

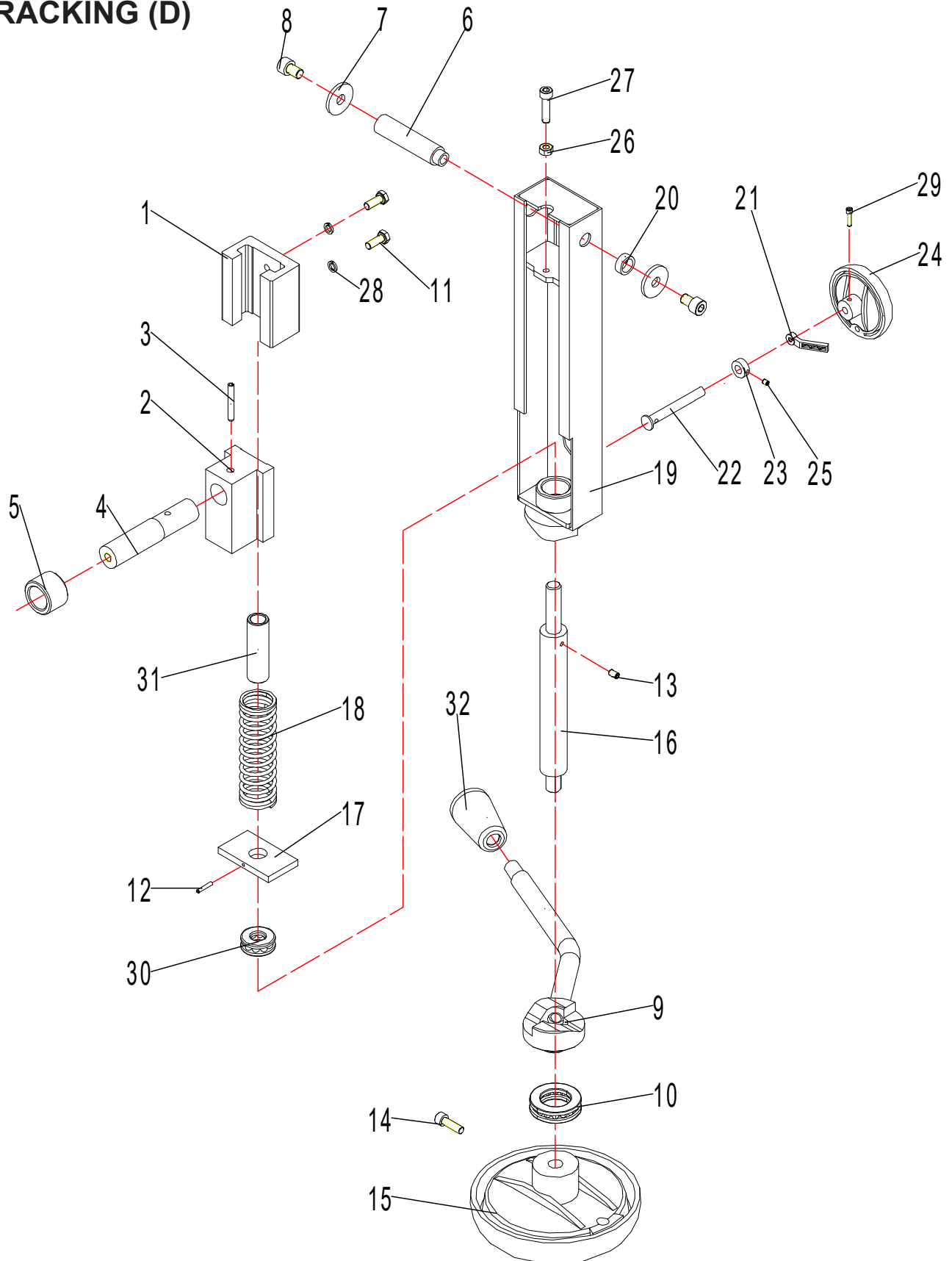

PARTS LIST

BLADE TENSION & TRACKING (D)

KEY NO.	DESCRIPTION	MFG. PART NO.	QTY.
1D	Sliding rail	P10-370-1D	1
2D	Upper wheel shaft hinge	P10-370-2D	1
3D	Roll pin	P10-370-3D	1
4D	Upper wheel shaft	P10-370-4D	1
5D	Bushing	P10-370-5D	1
6D	Support shaft	P10-370-6D	1
7D	Big washer	P10-370-7D	2
8D	Screw M8X10	P10-370-8D	2
9D	Shaft hinge	P10-370-9D	1
10D	Bearing	P10-370-10D	1
11D	Hex bolt M6X12	P10-370-11D	2
12D	Roll pin	P10-370-12D	1
13D	Set screw M5X12	P10-370-13D	1
14D	Hex socket cap screws M6X12	P10-370-14D	1
15D	Big hand wheel	P10-370-15D	1
16D	Crank	P10-370-16D	1
17D	Block	P10-370-17D	1
18D	Spring	P10-370-18D	1
19D	Slide bracket	P10-370-19D	1
20D	Bushing	P10-370-20D	1
21D	Lock handle	P10-370-21D	1
22D	Shaft	P10-370-22D	1
23D	Retaining ring	P10-370-23D	1
24D	Blade tension hand wheel	P10-370-24D	1
25D	Set screw M5X10	P10-370-25D	1
26D	Nut M6	P10-370-26D	1
27D	Hex socket cap screws M6X30	P10-370-27D	1
28D	Spring washer	P10-370-28D	2
29D	Hex socket cap screws M6X20	P10-370-29D	1
30D	Bearing	P10-370-30D	1
31D	Spring bushing	P10-370-31D	1
32D	Knob	P10-370-32D	1

NOTE: Please reference the Manufacturer's Part Number when calling for Replacement Parts.
For Parts under Warranty, the serial number of your machine is required.

PARTS DIAGRAM

DRIVE ASSEMBLY (E)

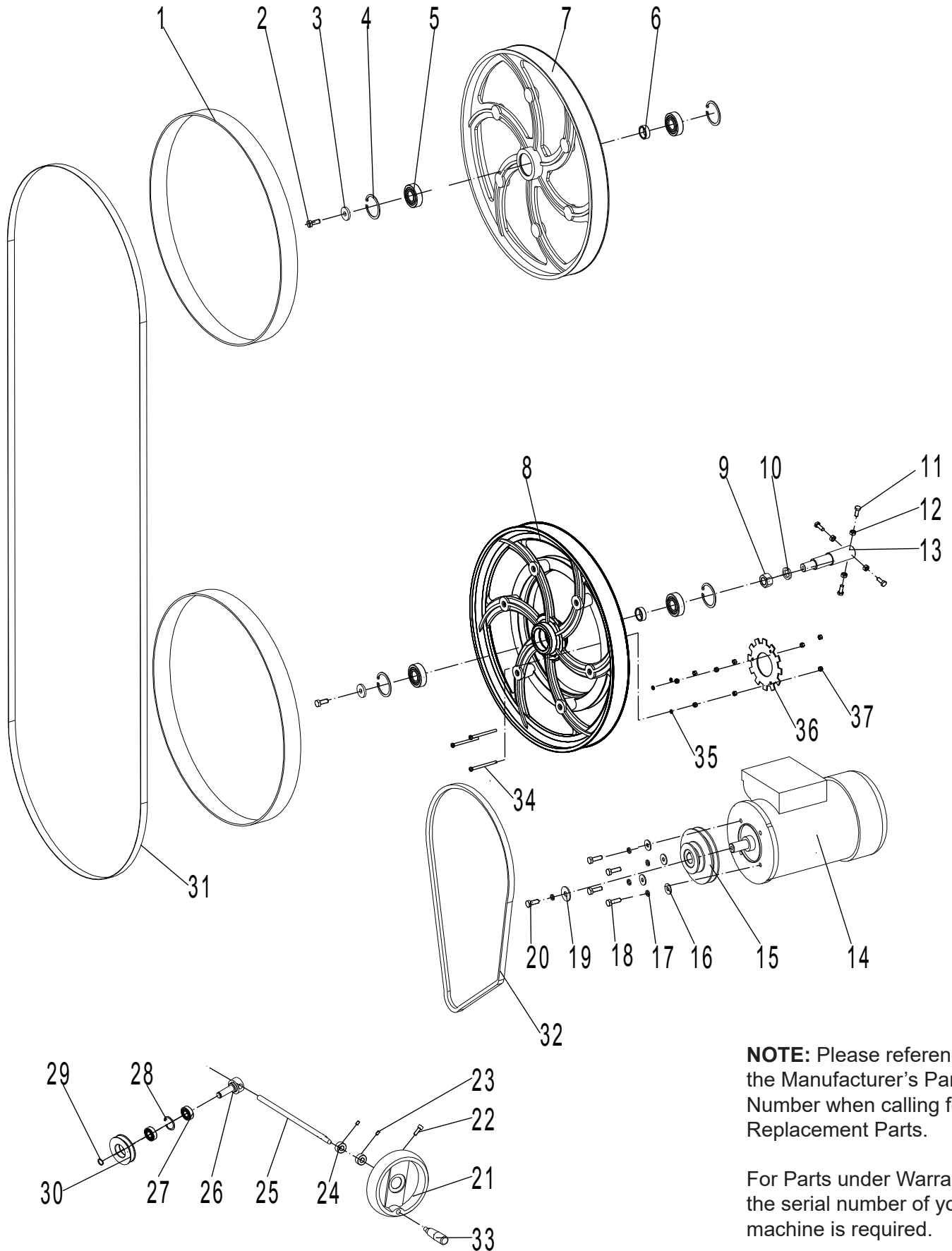

NOTE: Please reference the Manufacturer's Part Number when calling for Replacement Parts.

For Parts under Warranty, the serial number of your machine is required.

PARTS LIST

DRIVE ASSEMBLY (E)

KEY NO.	DESCRIPTION	MFG. PART NO.	QTY.
1E	Rubber tire	P10-370-1E	2
2E	Hex bolt M8X16	P10-370-2E	2
3E	Big washer	P10-370-3E	2
4E	Retaining ring	P10-370-4E	4
5E	Bearing 6204	P10-370-5E	4
6E	Tube	P10-370-6E	2
7E	Upper wheel	P10-370-7E	1
8E	Lower wheel	P10-370-8E	1
9E	Nut M27X2	P10-370-9E	1
10E	Washer	P10-370-10E	1
11E	Hex socket cap screws M8X25	P10-370-11E	4
12E	Nut M8	P10-370-12E	4
13E	Lower bandsaw wheel shaft	P10-370-13E	1
14E	Motor	P10-370-14E	1
15E	Motor pulley	P10-370-15E	1
16E	Big washer	P10-370-16E	4
17E	Spring washer	P10-370-17E	5
18E	Hex bolt M8X16	P10-370-18E	4
19E	Big washer	P10-370-19E	1
20E	Bolt M8X20	P10-370-20E	1
21E	Small hand wheel	P10-370-21E	1
22E	Hex socket cap screw M6X20	P10-370-22E	1
23E	Set screws M5X8	P10-370-23E	2
24E	Retainer ring	P10-370-24E	2
25E	Thread rod	P10-370-25E	1
26E	Shaft for V-belt pulley	P10-370-26E	1
27E	Bearing 6001	P10-370-27E	2
28E	Circlip Ring	P10-370-28E	1
29E	Ring M12	P10-370-29E	1
30E	V-Belt pulley	P10-370-30E	1
31E	Bandsaw blade	P10-370-31E	1
32E	Poly V-Belt	P10-370-32E	1
33E	Small handle	P10-370-33E	1
34E	Cross recess pan head screw M5x65	P10-370-34E	3
35E	Spring washer	P10-370-35E	3
36E	Digital display indes film	P10-370-36E	1
37E	Nut	P10-370-37E	9

RIKON CONTACT INFORMATION

Please visit our website www.rikontools.com for a complete listing of products and accessories for your machine.

You may place an order for parts by calling RIKON at 877-884-5167 M-F, 8:00-5:30 EST.

How-To's for all Band Saw Blades

Choosing the Correct Blade Width

Blade width is measured from the tips of the teeth to the back edge of the blade as shown above. The instructions for the particular machine being used should be followed when selecting blade width.



If no such instructions are provided, blade width should be determined with the following guidelines:

For Cut-Off Sawing, the blade should be as wide as the machine will allow. The wider the band is, the straighter the cut will be. Faster feeding can be achieved.

For Contour Sawing, the blade should be as wide as the machine allows, but still narrow enough so that it can cut the desired shape (radius). Minimum dimensions for different cutting radii are shown on the chart at right.

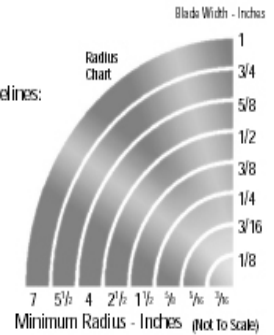

How To Choose The Correct Number Of Teeth Per Inch (TPI)

The number of teeth per inch (TPI) is important in obtaining the finish desired and the proper feed rate. A coarse tooth blade (2, 3 TPI) should be used for resawing wood and cutting thicker stock up to 8". A fine toothed blade (18 to 32 TPI) should be used for thinner metals and plastics under 1/4". For general cutting of 3/4" wood 4 TPI will provide a fast cut and 14 TPI will cut slow, but leave a smoother finish.

When Selecting TPI remember:

- More TPI give a smoother but slower cut
- Fewer TPI allow a faster cut with a slightly rougher finish
- At least three teeth must be in the workpiece—the chart to the right will help you decide.

TPI	Minimum Material Thickness
32	3/32"
24	1/8"
18	5/32"
14	1/4"
10	5/16"
8	3/8"
6	1/2"
4	3/4"
3	1"
2	1-1/2"

It is important to know the SFM for the various speed settings of your band saw, so that you can select the proper speed for cutting wood or other materials. Check the operator's manual of your band saw to determine the SFM or use the following procedure:

1. Determine the RPM: check the operator's manual or clock the revolutions per minute of the wheels with a tachometer or revolution counter.
2. Measure the diameter of the drive wheel in inches and multiply by .262 to obtain the wheel circumference. The RPM times circumference equals the surface speed of the blade.
 $RPM \times \text{diameter in inches} \times .262 = SFM.$

Note: Spring Steel Wood Cutting Band Saw Blades should never be operated at surface speeds above 3000 SFM. Carbon Hard Edge Flexible Back Band Saw Blades may be run up to 8000 SFM.

Installing your Band Saw Blade

1. Unplug the saw, then loosen the tension on the upper wheel. With all the blade guides backed off, slip the new blade around the wheels and then tension it.
2. When you have tensioned the blade enough to keep it on the wheels, track it by turning the upper wheel with one hand while adjusting the tilt of the wheel's axis with the other hand. The blade should ride in the middle of the rim. **Never track the blade with the motor running and the cover open.**
3. Next, adjust the blade guides; first the thrust bearings: upper and lower, then the left and right side guides.
4. Use a square to make sure you are not pushing the blade out of line and place a piece of white paper between the blade guide and the blade to allow for clearance.

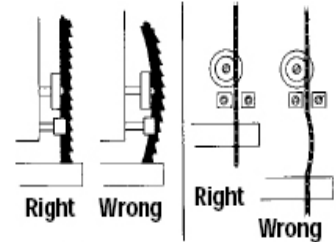

Diagnosing Problems

1. Premature and Excessive Tooth Wear

- Feed pressure too light, increase it.
- Lower band velocity.
- Improper tooth selection, use a finer pitch.
- Improper break-in with new band. Velocity and feeding should be reduced the first few cuts.
- Teeth are running the wrong direction.
- Be sure teeth are pointing in proper direction.
- Incorrect saw guide insert size for the band, allowing them to strike teeth

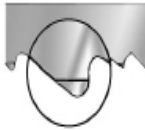

2. Blade Vibration

- Increase or decrease band velocity.
- Teeth too coarse for workpiece.
- Material not securely held.
- Increase tension of band.
- Increase feed pressure.

3. Gullets Loading

- Teeth too fine for workpiece - use a coarser pitch.
- Decrease band velocity.

4. Band Stalls in Work

- Feed pressure too great - decrease feed.
- Teeth too coarse, use finer tooth blade

5. Premature Blade Breakage

- Thickness of blade too heavy for diameter of wheels and speed of machine
- Increase or decrease velocity
- Check wheels for defects
- Teeth too coarse for workpiece - use a finer pitch
- Decrease blade tension - decrease feeding force
- Brittle weld - increase annealing period, decreasing heat gradually
- Check for proper adjustment of band guides, saw guides, saw guide inserts and back-up bearings.

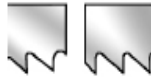

6. Blade Making Belly-Shaped Cuts

- Increase tension.
- Adjust guides closer to workpiece.
- Teeth too fine - use a coarse pitch.
- Decrease feed force.
- Teeth dull.

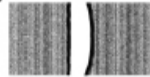

7. Tooth Stripping

- Teeth too coarse for workpiece.
- Material not securely held.
- Too much feed pressure - reduce for good chip curl.
- Band velocity too low - increase speed.



8. Band Develops a Negative Camber

- Band is riding on saw guide backup bearing too heavily. Adjust band for alignment on top and bottom wheels.
- Check band wheel alignment.



9. Blade Not Running True Against Saw Guide Backup Bearing

- If ticking noise against saw guide backup bearing, remove burr on band.
- Check band wheel alignment.
- Check saw guide backup bearing for wear, replace if necessary
- Weld not in proper alignment. Reweld blade straight and true.

10. Cutting Rate Too Slow

- Increase band velocity.
- Increase feed pressure.
- Use a coarser pitch.

11. Blade Leading In Cut

- Reduce feed pressure or rate.
- Check adjustments and wear of saw guides or rollers.
- Lack of band tension
- Tooth set damage



12. Premature Loss of Set

- Improper width selection - check chart for correct width for radius cutting.
- Reduce band velocity.

13. Band Develops Positive Camber

- Decrease force.
- Use a coarser pitch to increase tooth penetration.
- Adjust saw guides closer to work.



14. Band Develops Twist

- Wrong width for radius being cut - choose a narrower blade.
- Binding in cut - decrease feed pressure.
- Decrease band tension.
- Adjust saw guides further from workpiece.



15. Finished Cut Surface Too Rough

- Improper tooth selection - choose a finer pitch.
- Increase band velocity.
- Decrease feed rate.



16. Band Scoring (side wear or grooving)

- Check for wear on saw guide inserts
- Too much pressure on saw guide inserts
- Check alignment of saw guides - be sure they are square to front vise. Replace or clean guides.



17. Burring or Mushrooming of Blade Back Edge

- Increase tension and adjust guides.
- Check contact between blade and back edge rollers.
- Reduce feed pressure.
- Use coarser pitch blade.
- Use finishing stone.



ACCESSORIES

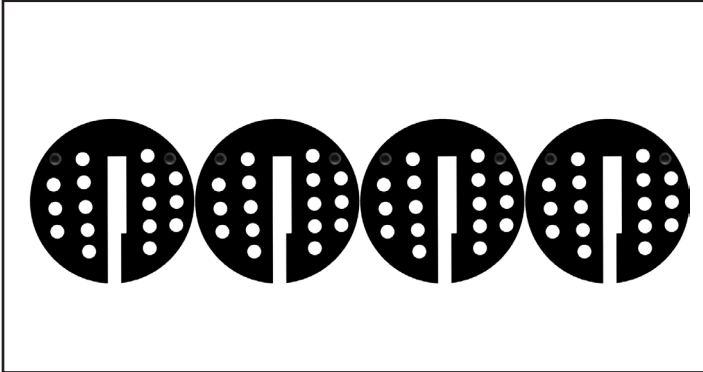

C10-391 TABLE INSERTS - PACK OF 4

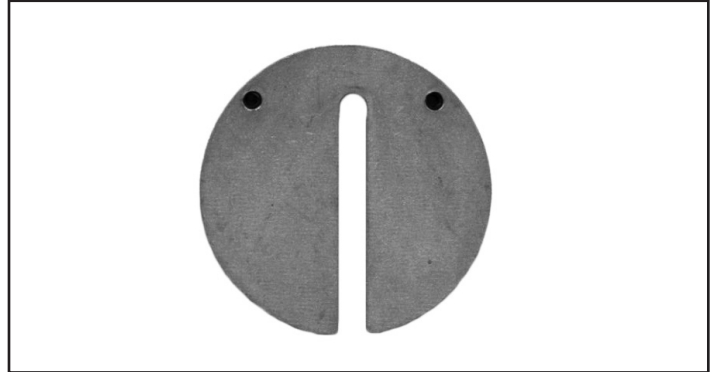

C10-395 ALUMINUM TABLE INSERT



13-912 'T' SLOT MITER GAUGE



C10-392 ZERO CLEARANCE INSERTS - PK 4

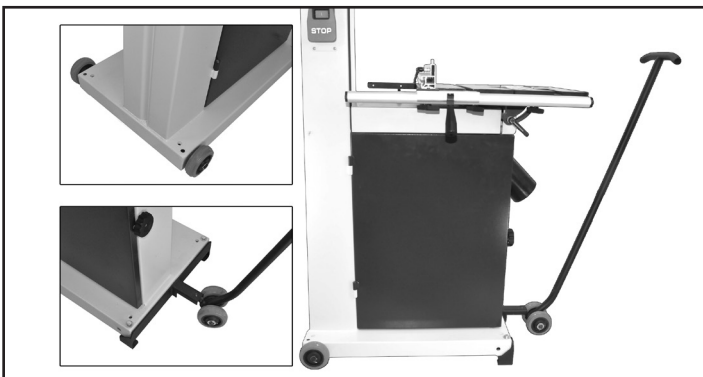

13-345 MOBILITY KIT

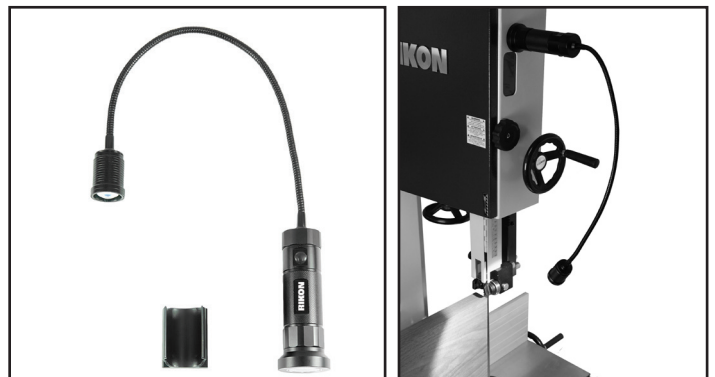

12-201 MAGNETIC BASE LED WORKLIGHT

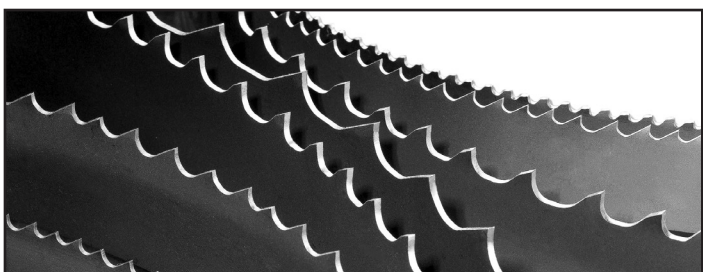

BAND SAW BLADES

For a complete line of 142" band saw blades, contact your local RIKON distributor, or visit the RIKON website at www.rikontools.com.

RIKON

POWER TOOLS®

5-Year Limited Warranty

RIKON Power Tools Inc. ("Seller") warrants to only the original retail consumer/purchaser of our products that each product be free from defects in materials and workmanship for a period of five (5) years from the date the product was purchased at retail. This warranty may not be transferred.

This warranty does not apply to defects due directly or indirectly to misuse, abuse, negligence, accidents, repairs, alterations, lack of maintenance or normal wear and tear. Under no circumstances will Seller be liable for incidental or consequential damages resulting from defective products. All other warranties, expressed or implied, whether of merchantability, fitness for purpose, or otherwise are expressly disclaimed by Seller. This five-year warranty does not cover products used for commercial, industrial or educational purposes. The warranty term for these claims will be limited to a two-year period.

This limited warranty does not apply to accessory items such as blades, drill bits, sanding discs, grinding wheels, belts, guide bearings and other related items.

Seller shall in no event be liable for death, injuries to persons or property, or for incidental, contingent, special, or consequential damages arising from the use of our products.

To take advantage of this warranty, proof of purchase documentation must be provided which has the date of purchase and an explanation of the complaint.

The Seller reserves the right to effect at any time, without prior notice, those alterations to parts, fittings, and accessory equipment which they may deem necessary for any reason whatsoever.

To register your machine online, visit RIKON at www.rikontools.com/warranty

**To take advantage of this warranty, or if you have any questions,
please contact us at 877-884-5167 or email warranty@rikontools.com**



**For more information:
16 Progress Road
Billerica, MA 01821**

**877-884-5167 / 978-528-5380
techsupport@rikontools.com**