

10" Planer / Jointer with Helical Cutterhead



Operator's Manual

Record the serial number and date of purchase in your manual for future reference.

Serial Number: _____ Date of purchase: _____

For technical support or parts questions, email techsupport@rikontools.com or call toll free at (877)884-5167

TABLE OF CONTENTS

Specifications.....	2
Safety Instructions	3 - 6
Getting To Know Your Machine	7
Contents of Package	7 - 8
Installation	8
Assembly	9 - 11
Adjustments.....	11 - 17
Operation	18 - 20
Maintenance	21
Electricals & Wiring Diagram	5 & 21
Troubleshooting	22 - 23
Parts Diagrams & Parts Lists	24 - 29
Accessories	30
Notes	30
Warranty	31

SPECIFICATIONS

Model No.	25-010H
Motor	
Horsepower	1-1/2 HP
Amps	16/8
Volts	110/220V, 60 Hz
RPM	3,400
Cutterhead	
Speed	4,800
Number of Knives/Inserts	Carbide Inserts (4 Sided) - 44
Cuts Per Minute	19,200
Diameter	2-1/2"
Fence	
Size	4-1/4" x 24-1/4"
Tilts	0° - 45°
Positive Stops	90°, 45° Right and Left
Planer	
Maximum Cutting Width	10"
Maximum Cutting Height	8"
Wood Feed Rate	24.6 SF/MIN
Table Size	10-1/4" x 15-3/4"
Jointer	
Maximum Cutting Width	10"
Maximum Cutting Depth	1/8"
Depth	1/2"
Table Size	11" x 40-1/2"
Overall	
Height	37"
Width	40-1/2"
Depth	N/A
Base Size	22-1/2" x 22"
Net Weight	147 lbs.
Shipping Weight	188 lbs.
Shipping Carton	28-1/4" x 22-1/4" x 22-1/2"
Warranty	5 Years

NOTE: The specifications, photographs, drawings and information in this manual represent the current model when the manual was prepared. Changes and improvements may be made at any time, with no obligation on the part of Rikon Power Tools, Inc. to modify previously delivered units. Reasonable care has been taken to ensure that the information in this manual is correct, to provide you with the guidelines for the proper safety, assembly and operation of this machine.

SAFETY INSTRUCTIONS

IMPORTANT! Safety is the single most important consideration in the operation of this equipment. **The following instructions must be followed at all times.** Failure to follow all instructions listed below may result in electric shock, fire, and/or serious personal injury.

There are certain applications for which this tool was designed. We strongly recommend that this tool not be modified and/or used for any other application other than that for which it was designed. If you have any questions about its application, do not use the tool until you have contacted us and we have advised you.

SAFETY SYMBOLS



SAFETY ALERT SYMBOL: Indicates DANGER, WARNING, or CAUTION. This symbol may be used in conjunction with other symbols or pictographs.



Indicates an imminently hazardous situation, which, if not avoided, could result in death or serious injury.



Indicates a potentially hazardous situation, which, if not avoided, could result in death or serious injury.



Indicates a potentially hazardous situation, which, if not avoided, could result in minor or moderate injury.

NOTICE: Shown without Safety Alert Symbol indicates a situation that may result in property damage.

GENERAL SAFETY

KNOW YOUR POWER TOOL. Read the owner's manual carefully. Learn the tool's applications, work capabilities, and its specific potential hazards.

BEFORE USING YOUR MACHINE

To avoid serious injury and damage to the tool, read and follow all of the Safety and Operating Instructions before operating the machine.

1. Some dust created by using power tools contains chemicals known to the State of California to cause cancer, birth defects, or other reproductive harm.

Some examples of these chemicals are:

- Lead from lead-based paints.
- Crystalline silica from bricks, cement, and other masonry products.
- Arsenic and chromium from chemically treated lumber.

Your risk from these exposures varies, depending on how often you do this type of work. To reduce your exposure to these chemicals: work in a well ventilated area and work with approved safety equipment, such as those dust masks that are specially designed to filter out microscopic particles.

2. **READ** the entire Owner's Manual. **LEARN** how to use the tool for its intended applications.

3. **GROUND ALL TOOLS.** If the tool is supplied with a 3 prong plug, it must be plugged into a 3-contact electrical receptacle. The 3rd prong is used to ground the tool and provide protection against accidental electric shock. **DO NOT** remove the 3rd prong. See Grounding Instructions on the following pages.

4. **AVOID A DANGEROUS WORKING ENVIRONMENT.** **DO NOT** use electrical tools in a damp environment or expose them to rain.

5. **DO NOT** use electrical tools in the presence of flammable liquids or gases.

6. **ALWAYS** keep the work area clean, well lit, and organized. **DO NOT** work in an environment with floor surfaces that are slippery from debris, grease, and wax.

7. **KEEP VISITORS AND CHILDREN AWAY. DO NOT** permit people to be in the immediate work area, especially when the electrical tool is operating.

8. **DO NOT FORCE THE TOOL** to perform an operation for which it was not designed. It will do a safer and higher quality job by only performing operations for which the tool was intended.

9. **WEAR PROPER CLOTHING. DO NOT** wear loose clothing, gloves, neckties, or jewelry. These items can get caught in the machine during operations and pull the operator into the moving parts. The user must wear a protective cover on their hair, if the hair is long, to prevent it from contacting any moving parts.

10. **CHILDPROOF THE WORKSHOP AREA** by removing switch keys, unplugging tools from the electrical receptacles, and using padlocks.

11. **ALWAYS UNPLUG THE TOOL FROM THE ELECTRICAL RECEPTACLE** when making adjustments, changing parts or performing any maintenance.

SAFETY INSTRUCTIONS

12. KEEP PROTECTIVE GUARDS IN PLACE AND IN WORKING ORDER.

13. AVOID ACCIDENTAL STARTING. Make sure that the power switch is in the “OFF” position before plugging in the power cord to the electrical receptacle.

14. REMOVE ALL MAINTENANCE TOOLS from the immediate area prior to turning “ON” the machine.

15. USE ONLY RECOMMENDED ACCESSORIES. Use of incorrect or improper accessories could cause serious injury to the operator and cause damage to the tool. If in doubt, check the instruction manual that comes with that particular accessory.

16. NEVER LEAVE A RUNNING TOOL UNATTENDED. Turn the power switch to the “OFF” position. **DO NOT** leave the tool until it has come to a complete stop.

17. DO NOT STAND ON A TOOL. Serious injury could result if the tool tips over, or you accidentally contact the tool.

18. DO NOT store anything above or near the tool where anyone might try to stand on the tool to reach it.

19. MAINTAIN YOUR BALANCE. DO NOT extend yourself over the tool. Wear oil resistant rubber soled shoes. Keep floor clear of debris, grease, and wax.

20. MAINTAIN TOOLS WITH CARE. Always keep tools clean and in good working order. Keep all blades and tool bits sharp, dress grinding wheels and change other abrasive accessories when worn.

21. EACH AND EVERY TIME, CHECK FOR DAMAGED PARTS PRIOR TO USING THE TOOL. Carefully check all guards to see that they operate properly, are not damaged, and perform their intended functions. Check for alignment, binding or breaking of moving parts. A guard or other part that is damaged should be immediately repaired or replaced.

22. DO NOT OPERATE TOOL WHILE TIRED, OR UNDER THE INFLUENCE OF DRUGS, MEDICATION OR ALCOHOL.

23. SECURE ALL WORK. Use clamps or jigs to secure the workpiece. This is safer than attempting to hold the workpiece with your hands.

24. STAY ALERT, WATCH WHAT YOU ARE DOING, AND USE COMMON SENSE WHEN OPERATING A POWER TOOL.

A moment of inattention while operating power tools may result in serious personal injury.

25. ALWAYS WEAR A DUST MASK TO PREVENT INHALING DANGEROUS DUST OR AIRBORNE PARTICLES, including wood dust, crystalline silica dust and asbestos dust. Direct particles away from face and body. Always operate tool in well ventilated area and provide for proper dust removal. Use dust collection system wherever possible. Exposure to the dust may cause serious and permanent respiratory or other injury, including silicosis (a serious lung disease), cancer, and death. Avoid breathing the dust, and avoid prolonged contact with dust. Allowing dust to get into your mouth or eyes, or lay on your skin may promote absorption of harmful material. Always use properly fitting NIOSH/OSHA approved respiratory protection appropriate for the dust exposure, and wash exposed areas with soap and water.

26. USE A PROPER EXTENSION CORD IN GOOD CONDITION. When using an extension cord, be sure to use one heavy enough to carry the current your product will draw. The table on the following page shows the correct size to use depending on cord length and nameplate amperage rating. If in doubt, use the next heavier gauge. The smaller the gauge number, the larger diameter of the extension cord. If in doubt of the proper size of an extension cord, use a shorter and thicker cord. An undersized cord will cause a drop in line voltage resulting in a loss of power and overheating.
USE ONLY A 3-WIRE EXTENSION CORD THAT HAS A 3-PRONG GROUNDING PLUG AND A 3-POLE RECEPTACLE THAT ACCEPTS THE TOOL’S PLUG.

27. ADDITIONAL INFORMATION regarding the safe and proper operation of this product is available from:

- Power Tool Institute
1300 Summer Avenue
Cleveland, OH 44115-2851
www.powertoolinstitute.org
- National Safety Council
1121 Spring Lake Drive
Itasca, IL 60143-3201
www.nsc.org
- American National Standards Institute
25 West 43rd Street, 4th Floor
New York, NY 10036
www.ansi.org
- ANSI 01.1 Safety Requirements for Woodworking Machines and the U.S. Department of Labor regulations
www.osha.gov

28. SAVE THESE INSTRUCTIONS. Refer to them frequently and use them to instruct others.

SAFETY INSTRUCTIONS

ELECTRICAL SAFETY

⚠ WARNING: THIS TOOL MUST BE GROUNDED WHILE IN USE TO PROTECT THE OPERATOR FROM ELECTRIC SHOCK.

IN THE EVENT OF A MALFUNCTION OR BREAKDOWN, grounding provides the path of least resistance for electric current and reduces the risk of electric shock. This tool is equipped with an electric cord that has an equipment grounding conductor and requires a grounding plug (not included). The plug **MUST** be plugged into a matching electrical receptacle that is properly installed and grounded in accordance with **ALL** local codes and ordinances.

DO NOT MODIFY ANY PLUG. If it will not fit the electrical receptacle, have the proper electrical receptacle installed by a qualified electrician.

IMPROPER ELECTRICAL CONNECTION of the equipment grounding conductor can result in risk of electric shock. The conductor with the green insulation (with or without yellow stripes) is the equipment grounding conductor. **DO NOT** connect the equipment grounding conductor to a live terminal if repair or replacement of the electric cord or plug is necessary.

CHECK with a qualified electrician or service personnel if you do not completely understand the grounding instructions, or if you are not sure the tool is properly grounded when installing or replacing a plug.

USE ONLY A 3-WIRE EXTENSION CORD THAT HAS THE PROPER TYPE OF A 3-PRONG GROUNDING PLUG THAT MATCHES THE MACHINE'S 3-PRONG PLUG AND ALSO THE 3-POLE RECEPTACLE THAT ACCEPTS THE TOOL'S PLUG. *

REPLACE A DAMAGED OR WORN CORD IMMEDIATELY.

This tool is intended for use on a circuit that has a 120 volt electrical receptacle. **FIGURE A** shows the type of the 220v, 3-wire electrical plug and electrical receptacle that has a grounding conductor that is required if the motor wiring is changed. See page 21.

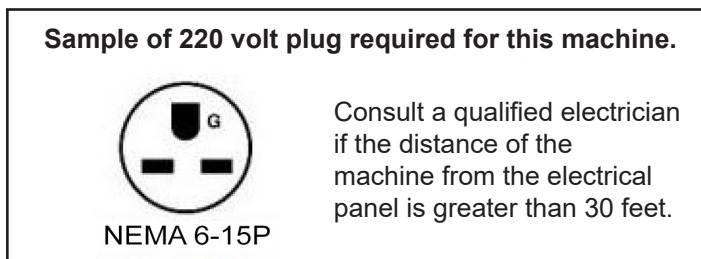

FIG. A

EXTENSION CORDS

⚠ WARNING: THE USE OF AN EXTENSION CORD WITH THIS MACHINE IS NOT RECOMMENDED. For best power and safety, plug the machine directly into a dedicated, grounded electrical outlet that is within the supplied cord length of the machine.

If an extension cord needs to be used, it should only be for a limited operation of the machine. The extension cord should be as short as possible in length, and have a minimum gauge size of 14AWG.

⚠ WARNING: Check extension cords before each use. If damaged replace immediately. Never use a tool with a damaged cord, since touching the damaged area could cause electrical shock, resulting in serious injury.

Use a proper extension cord. Only use cords listed by Underwriters Laboratories (UL). Other extension cords can cause a drop in line voltage, resulting in a loss of power and overheating of tool. When operating a power tool outdoors, use an outdoor extension cord marked "W-A" or "W". These cords are rated for outdoor use and reduce the risk of electric shock.

MINIMUM RECOMMENDED GAUGE FOR EXTENSION CORDS (AWG)				
120 VOLT OPERATION ONLY				
	25' LONG	50' LONG	100' LONG	150' LONG
0 to 6 Amps	18 AWG	16 AWG	16 AWG	14 AWG
6 to 10 Amps	18 AWG	16 AWG	14 AWG	12 AWG
10 to 12 Amps	16 AWG	16 AWG	14 AWG	12 AWG

⚠ WARNING: Keep the extension cord clear of the working area. Position the cord so that it will not get caught on lumber, tools or other obstructions while you are working with your power tool.

* Canadian electrical codes require extension cords to be certified SJT type or better.

** The use of an adapter in Canada is not acceptable.



THIS SYMBOL DESIGNATES THAT THIS TOOL IS LISTED BY THE INTERTEK TESTING SERVICES, TO UNITED STATES AND CANADIAN STANDARDS.

SAFETY INSTRUCTIONS

SPECIFIC SAFETY INSTRUCTIONS FOR PLANER / JOINTERS

This machine is intended for the surfacing of natural, solid woods. The permissible workpiece dimensions must be observed (see Technical Specification). Any other use not as specified, including modification of the machine or use of parts not tested and approved by the equipment manufacturer can cause unforeseen damage and invalidate the warranty.

ATTENTION: Use of this planer/jointer still presents risks that cannot be eliminated by the manufacturer. Therefore, the user must be aware that wood working machines are dangerous if not used with care and all safety precautions are adhered to.

1. Do not operate this machine until you have read all of the following instructions.
2. Do not attempt to operate this machine until it is completely assembled.
3. Do not turn ON this machine if any pieces are damaged or missing.
4. This machine must be properly grounded.
5. If you are not familiar with the operation of the machine, obtain assistance from a qualified person.
6. Always wear approved, safety protective eyewear and hearing protection when operating this machine.
7. Always wear a dust mask and use adequate dust collection and proper ventilation.
8. Do not wear loose clothing or jewelry when operating this machine. Keep long hair tied back.
9. Always make sure the power switch is in the OFF position prior to plugging in the machine.
10. Always make sure the power switch is in the OFF position and the machine is unplugged when doing any cleaning, assembly, setup operation, or when not in use.
11. Make sure all safety guards and hardware are securely tightened before operating the machine.
12. Regularly check that the blades are locked tight in the cutterhead.
13. Always keep hands and fingers away from the cutterhead, chip exhaust opening, feed rollers, belts and pulleys to prevent injury. Use push blocks when jointing wood shorter than 12" long, plus any narrow or thin stock.
14. Never joint wood less than 8" long, widths under 3/4", or material less than 1/4" thick.
15. Never make cuts deeper than 1/8". Multiple cuts, 1/16" or less, produce better finish results.
16. Make sure there are no loose knots, nails, staples, dirt or foreign objects in the workpiece to be surfaced.
17. Use extra caution with large, warped, very small or awkward workpieces. Joint warped boards flat before planing.
18. Use extra supports (roller stands, saw horses, tables etc, for any workpieces large enough to tip when not held down to the table top surfaces.
19. Surface wood in the same direction of the grain, not across the grain. Never plane end cuts or end grain.
20. Joint and plane only one workpiece at a time. Vary the feeding of the workpieces along the cutterhead, center/left/right, so that all of the knives get used and thus remain sharp, longer.
21. Never reach inside of a running machine, and avoid awkward operations and hand positions where a sudden slip could cause fingers or a hand to move into the cutterhead.
22. Do not clear a jammed workpiece while the machine is running. Stop the machine, unplug it from the power source, and then remove the jammed workpiece. Lowering the table may be necessary to dislodge the workpiece.
23. Keep your face and body to one side of the machine during use, out of line with a possible 'kick back' (lumber caught in by the rotating cutterhead and thrown back towards the operator).
24. The use of any accessories or attachments not recommended may cause injury to you and damage your machine.
25. Sharpen or replace dull or chipped knives immediately, as injury to the user, or the machine, may result.
26. Replacement knives/inserts should be from, or through a source recommended by the manufacturer.
27. Remove material or debris from the work area. Keep work area neat and clean.

This owner's manual is not a teaching aid and is intended to show assembly, adjustments, and general use.

CALIFORNIA PROPOSITION 65 WARNING: Some dust created by power sanding, sawing, grinding, drilling, and other construction activities contains chemicals known to the State of California to cause cancer and birth defects or other reproductive harm. Your risk from exposure to these chemicals varies, depending on how often you do this type of work. To reduce your exposure, work in a well-ventilated area and with approved safety equipment, such as dust masks that are specially designed to filter out microscopic particles.

For more detailed information about California Proposition 65 log onto rikontools.com.

GETTING TO KNOW YOUR MACHINE

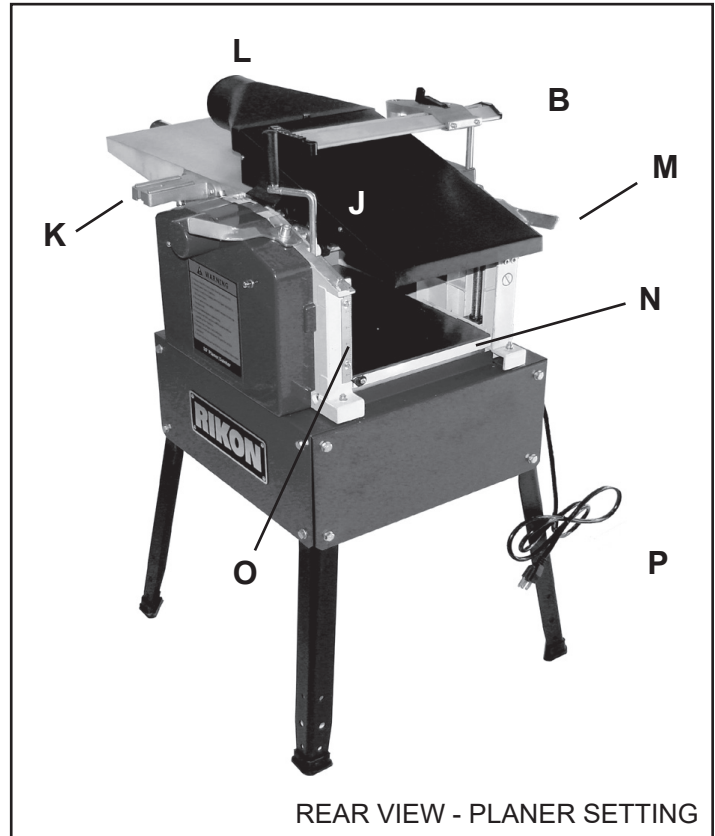
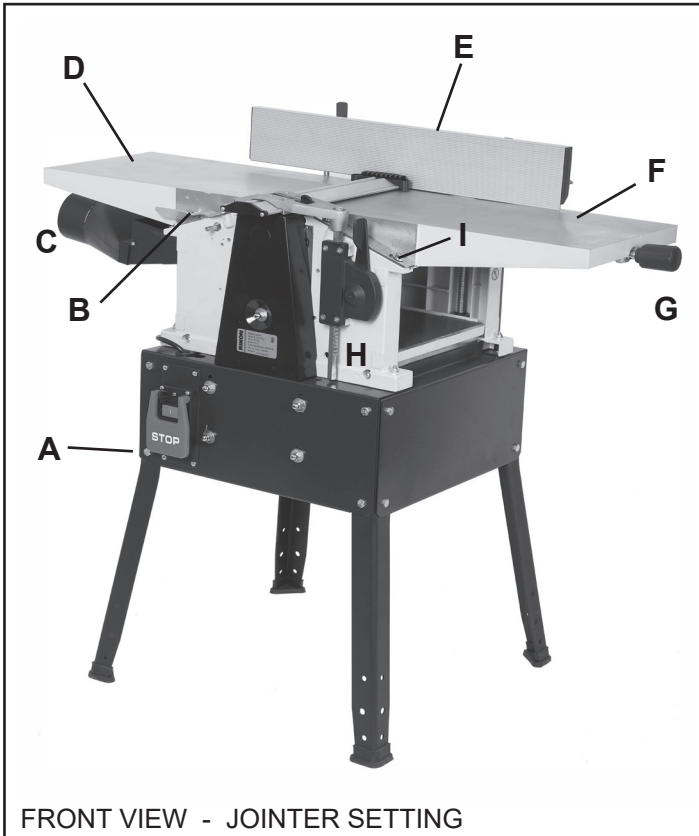

- A On / Off Safety Switch
- B Cutterhead Guard
- C Jointer Dust Port - Work Position
- D Outfeed Table
- E Jointer Fence
- F Infeed Table
- G Jointer Depth of Cut Adjustment Knob
- H Cutterhead Guard Height Adjustment Lever

- I Jointer Depth of Cut Scale
- J Planer Table Height Adjustment Handle
- K Jointer Fence Support
- L Planer Dust Port - Work Position
- M Outfeed Table Lock Handles
- N Planer Table
- O Planer Depth Gauge
- P Power Cord

CONTENTS OF PACKAGE

Model 25-010H Planer/Jointer is shipped complete in one box.

Unpacking and Clean-up

1. Carefully remove all contents from the shipping carton. Compare the contents with the list of contents to make sure that all of the items are accounted for, before discarding any packing material. Place parts on a protected surface for easy identification and assembly. If any parts are missing or broken, please call RIKON Customer Service (877-884-5167) as soon as possible for replacements. DO NOT turn your machine ON if any of these items are missing. You may cause injury to yourself or damage to the machine.
2. Report any shipping damage to your local distributor.
3. Clean all rust protected surfaces with ordinary house hold type grease or spot remover. Do not use; gasoline, paint thinner, mineral spirits, etc. These may damage painted surfaces.
4. Apply a coat of paste wax to the table to prevent rust. Wipe all parts thoroughly with a clean dry cloth. Be careful when reaching inside of the planer as the knives are sharp and may cause injury if touched.

CONTENTS OF PACKAGE

LIST OF LOOSE PARTS

- A. Outfeed Table
- B. Infeed Table
- C. Fence Assembly
- D. Legs & Floor Pads
- E. Dust Hood
- F. Depth of Cut Control Bar
- G. Nuts & Bolts for Leg Assembly
- H. Handle
- I. Tools
 - a. - Wrenches - 10 & 13mm
 - b. - Star T25 Screwdriver
 - c. - Hex Wrenches - 3, 4 & 5mm

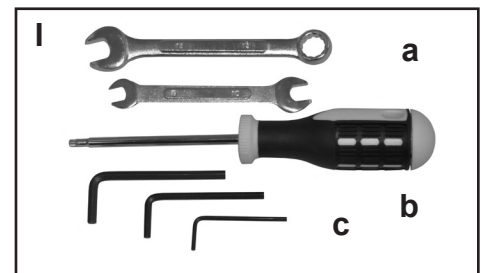
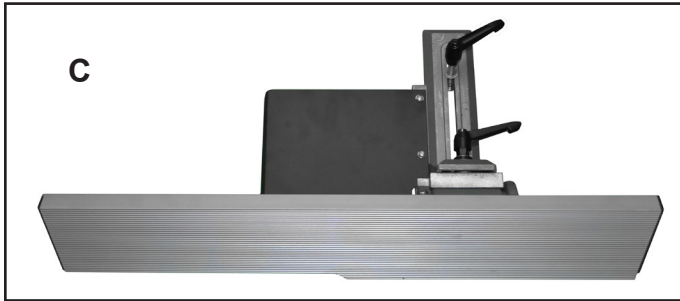
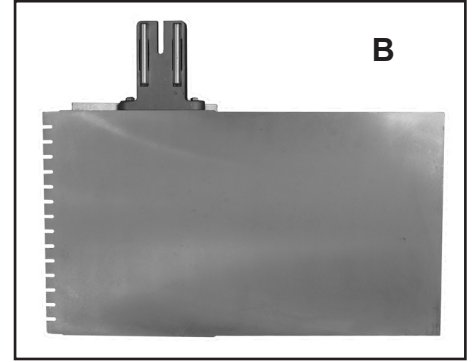
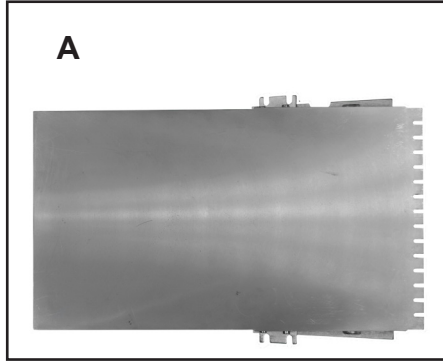

INSTALLATION

MOVING & INSTALLING THE PLANER

CAUTION When moving the planer/jointer, lift and move the machine with your hands holding the undersides of the machine's body. FIG. 1, A. DO NOT move or carry the planer/jointer with the infeed and outfeed tables, as this may damage the machine.

1. Position the machine on a solid, level foundation that is located in an area that ample space in front and in back of the planer/jointer for the moving of lumber to be milled. Align the machine so that during use, any kickback will not face aisles, doorways, or other work areas that bystanders may be in. Do not locate or use the machine in damp or wet conditions.
2. For best operation, the Planer/Jointer should be directly plugged into a power source, without the use of extensions.
3. The use of a industrial Dust Collector with a minimum of 650 CFM suction is recommended for chip removal.

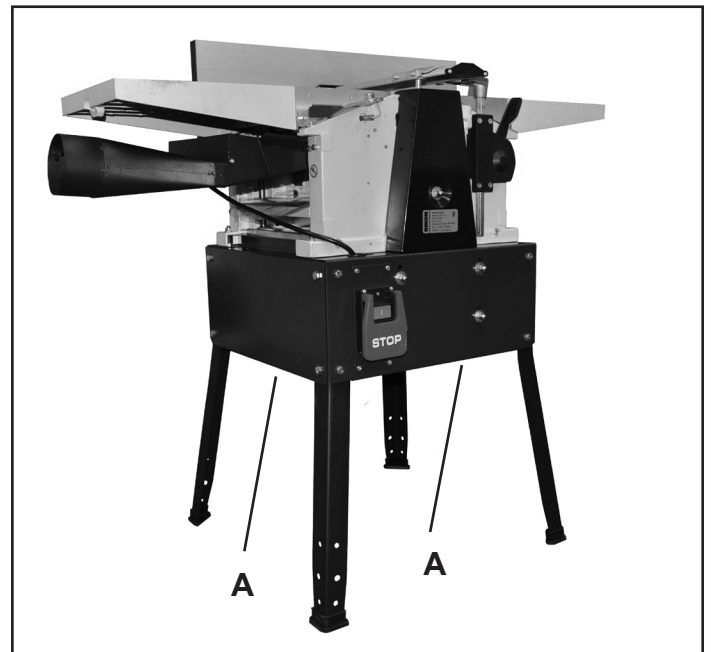

FIG. 1

ASSEMBLY



WARNING

THE MACHINE MUST NOT BE PLUGGED IN AND THE POWER SWITCH MUST BE IN THE 'OFF' POSITION UNTIL ASSEMBLY IS COMPLETE.

LEG INSTALLATION



CAUTION To install the legs, the machine must be placed onto its side to gain access to the underside to secure the nuts and washers. The machine is heavy. Additional help, or a suitable lifting device or support, will be required for lifting the machine onto the stand once the legs are installed.

NOTE: When assembling this Planer/Jointer, DO NOT fully tighten the nuts and bolts until the assembly is complete.

1. Before laying the machine down on its side, lay down some soft padding to protect the machine parts.

NOTE: The waste packaging may be utilized to support the machine, preventing damage. This is especially needed if the machine is laid on the side which has a plastic cover or the On/Off switch.

2. Gently lay the machine onto its side. Ensuring that the weight of the machine is distributed equally across the main frame.

3. Fasten the four Legs to the main frame of the machine, using the Bolts, Washers and Nuts provided. FIG. 2, 3.

4. Once the four legs have been secured to the main frame, it may not be possible to fully tighten the lower bolts until the machine is in the upright position.

5. With assistance, or with a suitable lifting device, return the machine to an upright position. All four legs should be stable, secure and on a level footing before final tightening the bolts. If machine does not sit on the legs properly, loosen all of the leg bolts and allow the machine's weight to settle onto the legs evenly. Then fully tighten the bolts to secure the legs in position. FIG. 4.

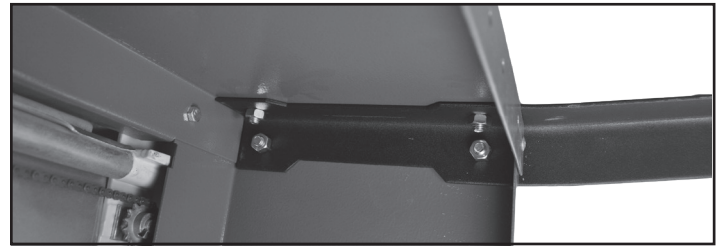

FIG. 2

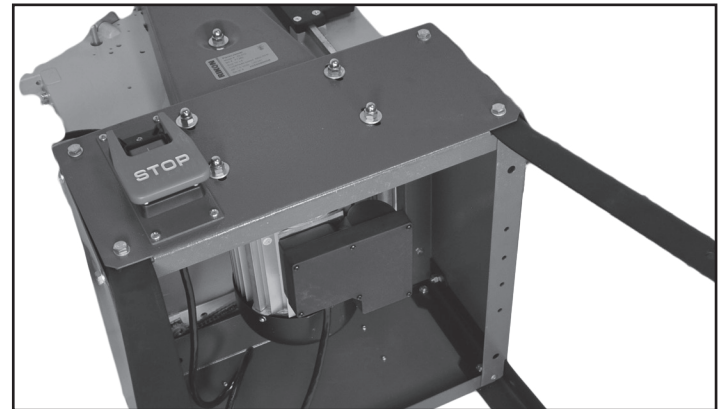

FIG. 3



FIG. 4

INFEEED TABLE INSTALLATION

1. Remove the four socket head cap screws (#123) from the infeed table's Cover Rails (#125) that have been pre-installed on the sides of the machine's frame. FIG. 5.

2. Remove the Collar and Spring Washer from the infeed table's depth of cut adjustment Bar (#119). FIG. 6.

Continued on page 10

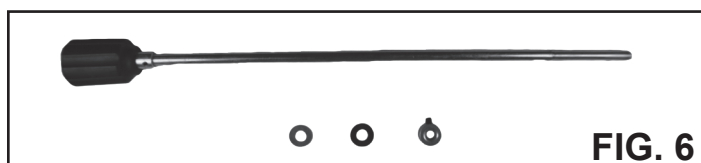

FIG. 6

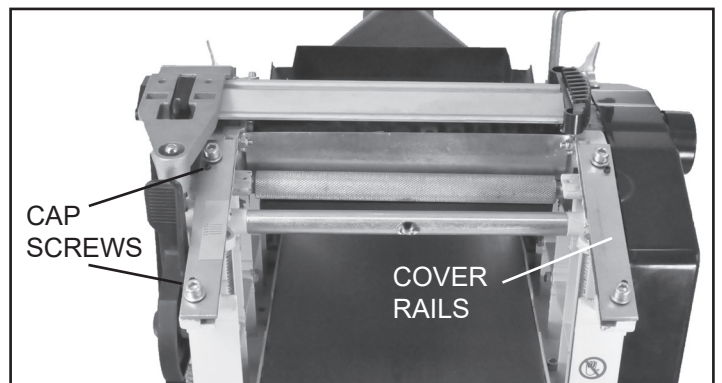

FIG. 5

ASSEMBLY

Installing the Infeed Table - Continued from page 9

3. Insert the bar through the table's end hole and under-side of the table. Then re-attach the Spring Washer and Collar onto the Bar to secure it in place. FIG. 7.
4. Hold the infeed table up to the machine while threading the depth of cut control bar into the Spacer Shaft (#137). FIG. 8.
5. Install the infeed table by positioning it under the table cover rails and wind the depth of cut bar until the uppermost line on the depth Scale is registered. FIG. 15. Re-fit and secure the table cover rails, FIG. 9.
NOTE: These rails should not be fully tightened, as the table needs to slide up and down in order to adjust the depth of cut. As a guide, fully tighten the socket head cap screws and then back them off a 1/4 turn.
6. See page 12 for instructions on adjusting the table.

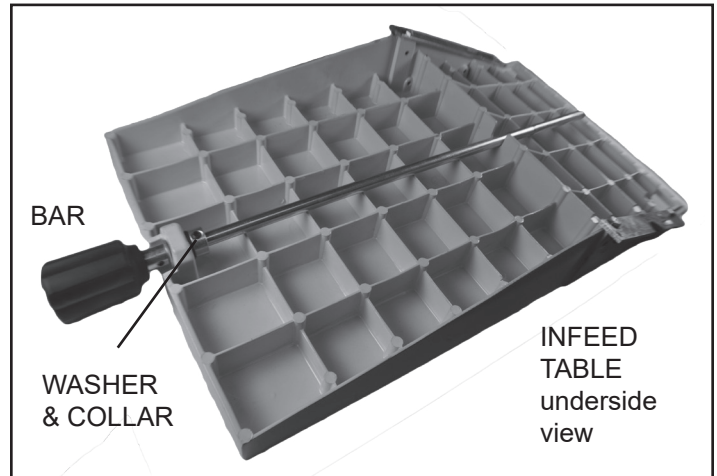

FIG. 7

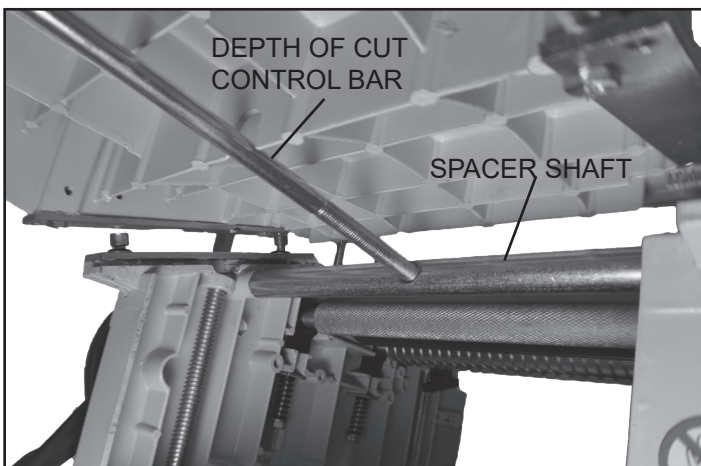

FIG. 8

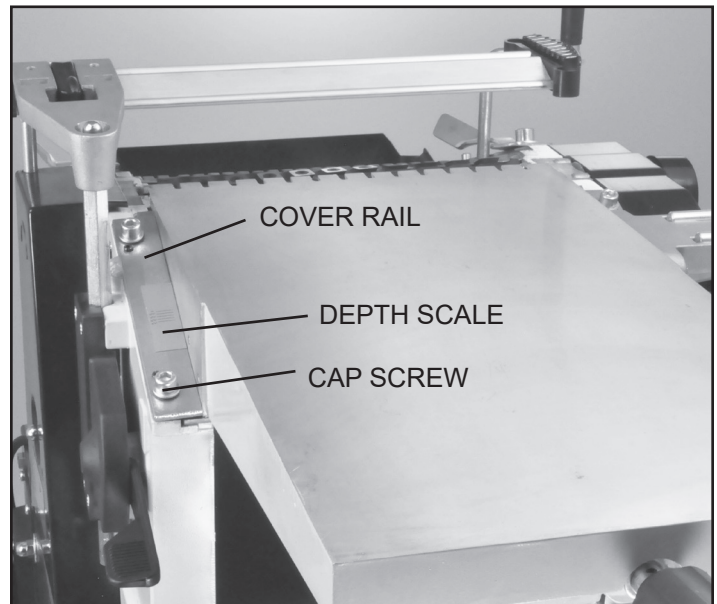

FIG. 9

DUST OUTLET INSTALLATION

1. At the opposite, outfeed end of the machine, locate the Chip Ejector Hood (#194). FIG. 10. Attach the Dust Port (#195) to the outlet with the two hex Bolts provided. FIG. 11

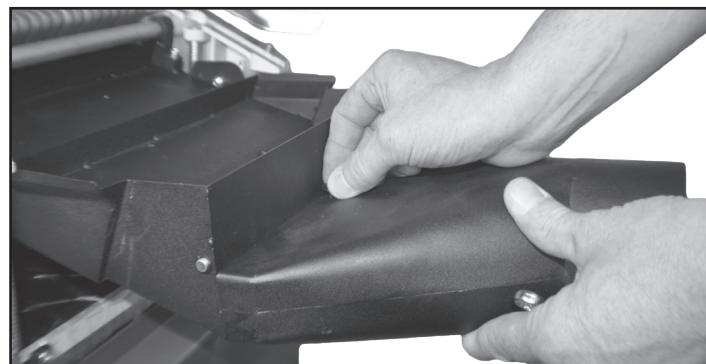

FIG. 10

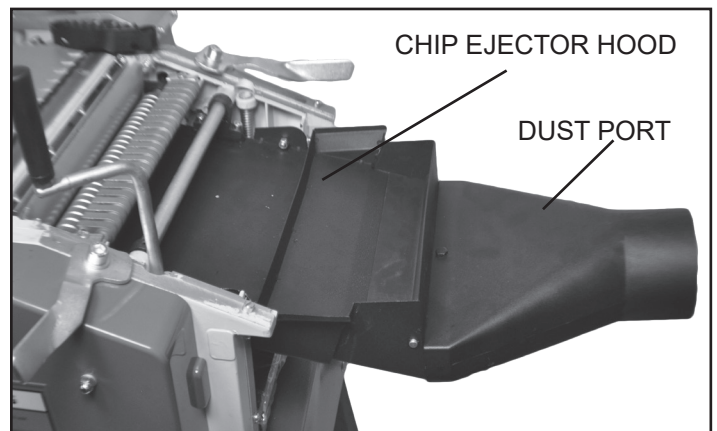

FIG. 11

ASSEMBLY



WARNING

THE MACHINE MUST NOT BE PLUGGED IN AND THE POWER SWITCH MUST BE IN THE 'OFF' POSITION UNTIL ASSEMBLY IS COMPLETE.

OUTFEED TABLE INSTALLATION

1. Position the outfeed table onto the left end of the machine frame. The two Setting Brackets (#158) fit over the pre-installed Pan Head, Location Screws (#160) on the frame for positioning, and then lock the table in place with the Levers (#233, 234). FIG. 12 & 13.

2. See page 12 for instructions on adjusting the table.

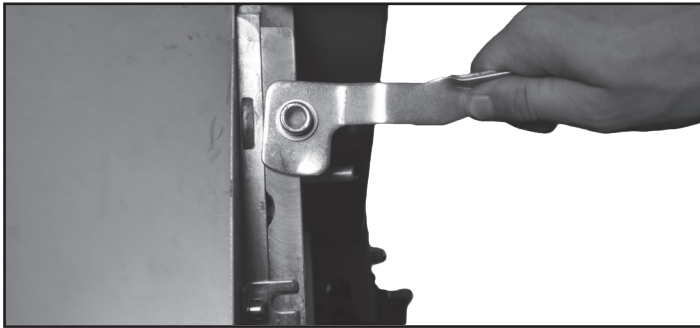

FIG. 13

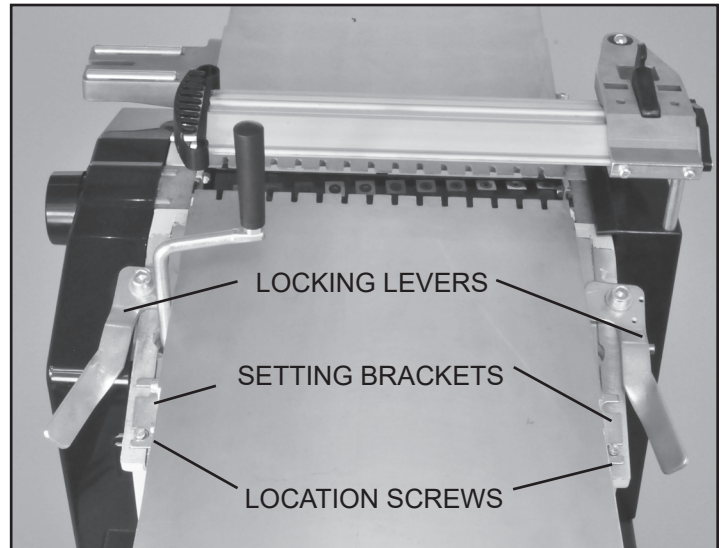

FIG. 12

JOINTER FENCE INSTALLATION

1. The Fence Carrier Support Bracket (#240, FIG. 14, A) has been pre-installed onto the rear side of the infeed table.

2. Slide the Fence Assembly onto the Fence Bracket and the secure it in position with the Ratchet Lever (#217).

3. See page 13 for instructions on adjusting the fence.

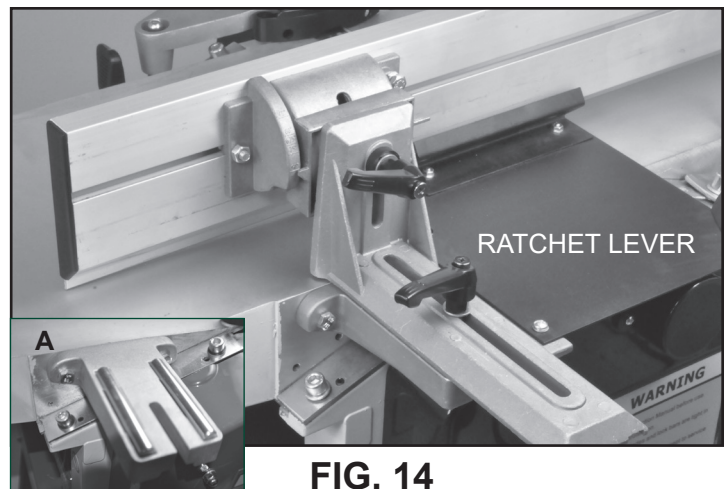

FIG. 14

ADJUSTMENTS

JOINTER TABLE ALIGNMENT

For the best surfacing of workpieces, the jointer's infeed and outfeed tables must be set at the same level to form a large 'flat' surface. These tables must also be in alignment with the cutterhead for true surfacing, when you measure the flatness of a board from side-to-side and end-to-end.

The machine has been factory set before shipping - the infeed table being set to the cutterhead knives, and then the outfeed table set to the infeed table. But once the machine has been set in its final location in the shop, the table alignments should be checked to make sure that there has been no movement during its handling.

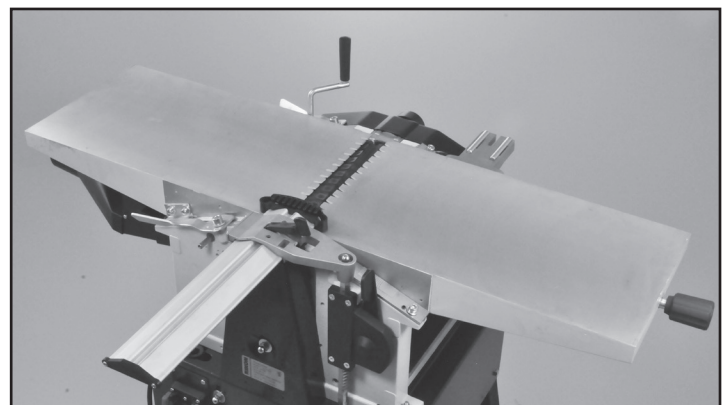

Continued on page 12

ADJUSTMENTS

INFEED TABLE ADJUSTMENT

The Infeed Table is pre-set at the factory to be aligned with the cutterhead. To ensure that both the infeed and outfeed jointer tables are aligned, check both table settings and adjust the outfeed table as necessary.

1. The infeed table should be set to the upper line on the Depth Scale. There is a thin Line cut into the metal side of the infeed table for indicating the table position with the cutterhead for regulating the depth of cut. FIG. 15.

NOTE: The jointer's depth of cut can be set by using the various lines on the scale. The top line is zero and the bottom line indicates a 1/8" (3mm) cut. It is not advised to take the deepest cut. Taking multiple cuts of 1/16" or less produce better finish results, and be much easier on the machine.

2. To increase or decrease the depth of cut, simply rotate the infeed adjustment knob. FIG. 16.

OUTFEED TABLE ADJUSTMENT

Check the Outfeed Table to ensure that it is aligned with the cutterhead and infeed table. Make adjustments to the outfeed table as follows;

CAUTION This procedure involves close contact with the planer blades. Wear gloves to prevent injury to the hands. Make sure that the machine is disconnected from the power supply.

In order to accurately set the machine, it is first necessary to align the tables.

1. Set the infeed table to the '0' setting on its depth of cut scale (see Infeed Table Adjustment above, FIG. 15).

2. Rotate the cutterhead so that the knife inserts do not interfere with the measurements that will be taken.

3. With a long metal straight edge, place it length-wise along the outfeed table so that it extends onto the infeed table. The straight edge should lie level across BOTH tables. FIG. 17. They should be set at the same height and perfectly level to each other.

- If it does, the tables are true to each other.
- If the straight edge does not lie flat across both tables, then the tables must be adjusted. Tune the outfeed table, as the infeed table was factory set to the cutterhead.

4. Adjust the ANGLE and tilt of the outfeed table with the hex Guide Screws (#160) located on the rear areas on both of the Guide Rails (#159, 161). FIG. 18.

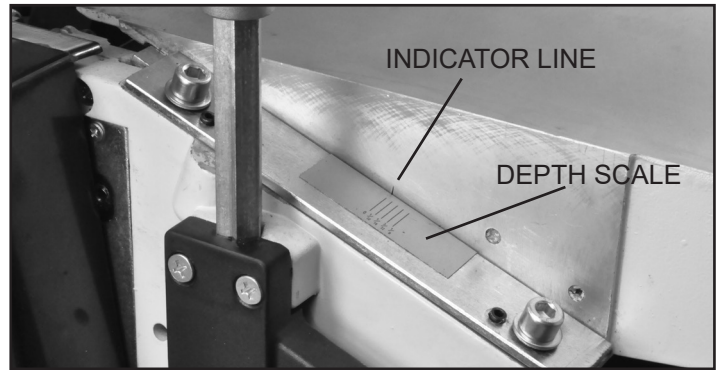

FIG. 15



FIG. 16

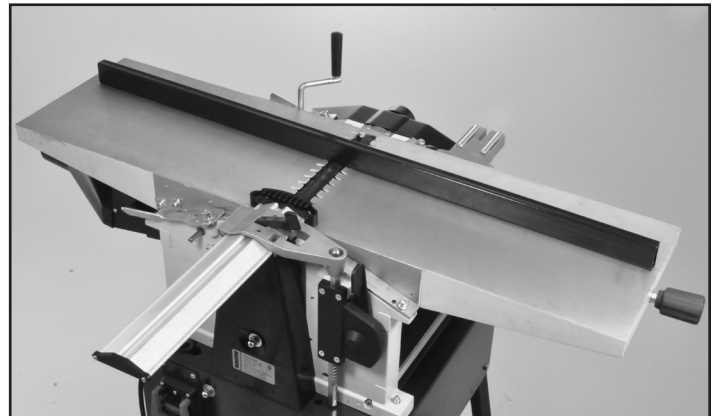

FIG. 17

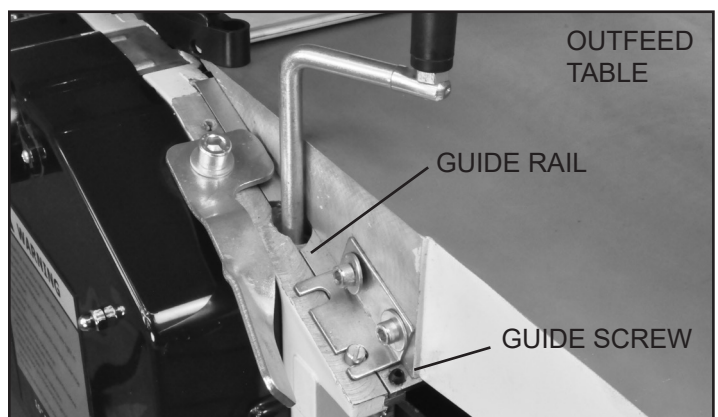

FIG. 18

ADJUSTMENTS

5. Check the alignment of the tables with the straight edge on both front and rear sides of the of the tables. Make further adjustments with the guide screws as necessary, until the tables are parallel with each other.

6. To adjust the HEIGHT of the table, loosen the hex Bolts that fasten the Brackets (#158) to the side of the outfeed table. Carefully slide the table forward or backwards to change the table height. FIG. 19. Re-fasten the bracket's hex bolts once the two tables are level with each other.

NOTE: To make this adjustment, you could also measure the height difference between tables with dividers or callipers. Then remove the outfeed table and re-set the bolts in the bracket's elongated holes to this measured distance.

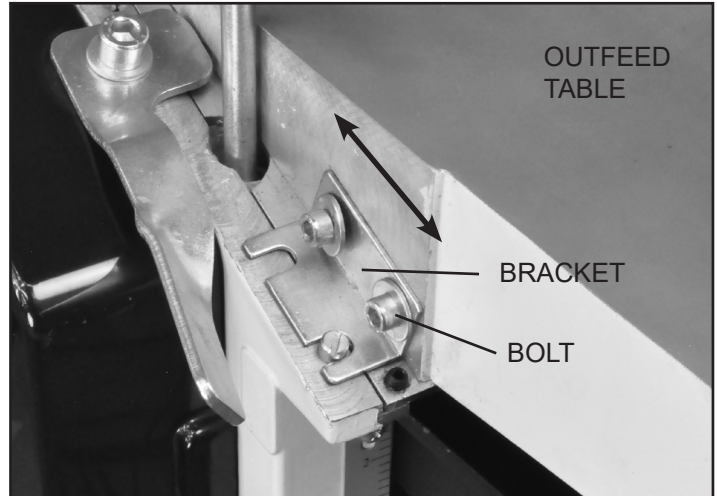

FIG. 19

JOINTER FENCE ADJUSTMENT

The jointer fence provides lateral support for the workpiece when surface planing. It can be tilted to any angle between 90° and -45°, and moved forward or backwards over the jointer bed and cutterhead to match the workpiece width. Once the fence is installed (page 11), it must be accurately set at 90°. To do this you will need an accurate square.

SETTING THE FENCE TO 90° AND 45°

1. Loosen the upper Ratchet Handle (#217) and adjust the fence into position against the square.
2. When the fence extrusion is exactly at 90°, tighten the upper ratchet handle to secure the position.
3. Set the rear, lower 90° Stop Screw (#221) on the fence Bracket (#201). This will ensure that the fence always returns to 90°. FIG. 20.

4. This same operation should also be carried out for setting the fence at the 45° angle, and fastening the upper 45° Stop Screw. FIG. 20. Note: the 45° angle is actually 135° from the jointer table.

SETTING THE FENCE ALONG THE TABLE LENGTH

The jointer fence can be moved forward or backward along the length of the jointer tables, and over the cutterhead, to allow for different board lengths.

1. On the rear of the fence, loosen the two hex Bolts which attach the Fence Bracket to the Fence through the long center slot in the fence rear. FIG. 21.
2. Move the fence to your desired position on the jointer.
3. Re-tighten the two hex bolts to secure the fence in its now position.

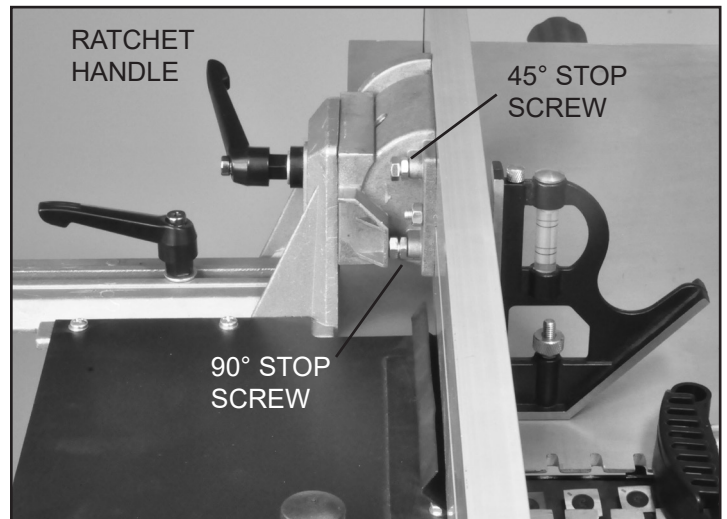

FIG. 20

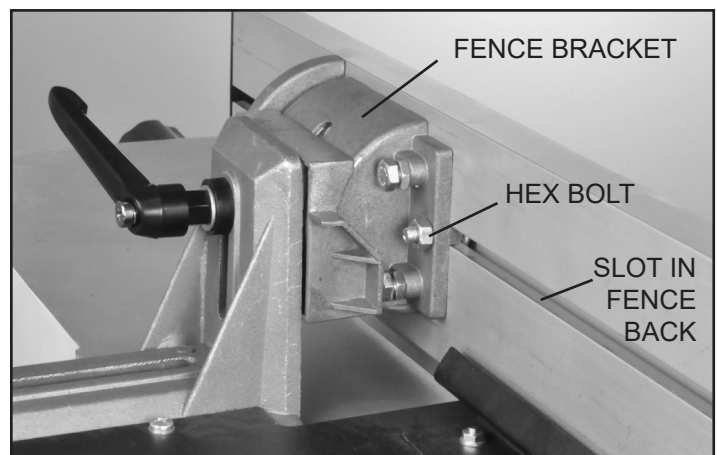

FIG. 21

ADJUSTMENTS

PLANER HEIGHT ADJUSTMENT

Height adjustment of the planer's table is made with the Handle (#130, FIG. 22, A). One full turn of the crank changes the height of the Planer's Table (#142, B) by 1/8".

- Clockwise Turning = raises the planer bed
- Counter-Clockwise Turning = lowers the planer bed.

The planing thickness is indicated on the Scale (#150, C).

CAUTION A maximum of 1/8" material can be removed in one pass through the planer. Do not exceed this depth of cut or damage to your machine may result. The maximum thickness of stock to be planed is 6-3/4", and the maximum width of boards is 10" wide.

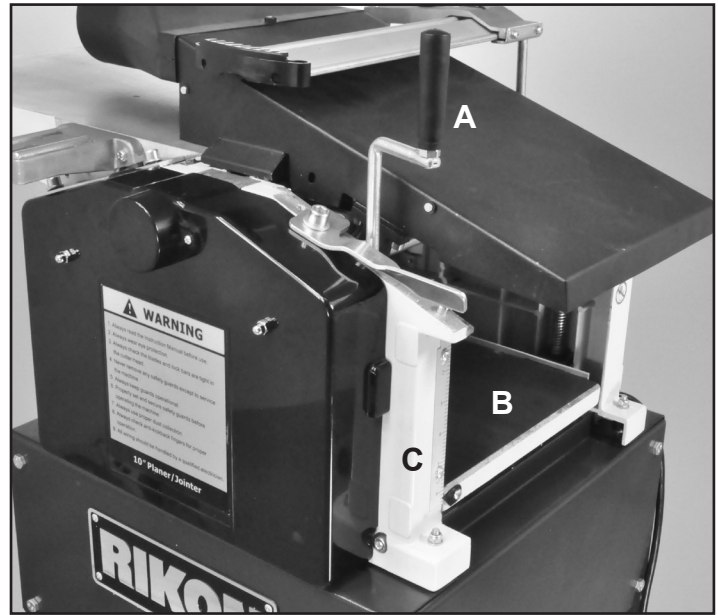

FIG. 22

PLANER TABLE ALIGNMENT

The machine has been factory set before shipping - the planer's table being set parallel to the cutterhead knives. But once the machine has been set in its final location in the shop, the table alignment should be checked to make sure that there has been no movement during its handling.

WARNING: When working on, or near the machine's bed, avoid the risk of personal injury by cuts that may result from touching the knife inserts' sharp edges!

1. Make sure that the planer/jointer's switch is turned off, and the plug is disconnected from the power source.
2. The cutterhead guard needs to be lifted up and the Dust Hood (#194) pivoted onto the infeed table in the planing use position, so adjustments can be made. FIG. 22.

NOTE: The cutterhead is fixed in position and any adjustments must be made through the table's setting.

3. To confirm that the planer table is set parallel to the cutterhead, measurements from the table surface to the underside of the cutterhead are made. The distance from the far right side of the planer's table should be the same as the distance taken at the far left of the table.
4. Place a Gauge Block (FIG. 23), or other measuring tool, onto the planer table, directly under the cutterhead.
5. Raise the table until with the handle until the gauge block makes contact with the cutterhead knife inserts, or the solid body of the cutterhead cylinder.



FIG. 23

6. Move the gauge block to the other side of the table to check to see if the gauge block is at the same measurement. If the distance is not the same, then the planer table has to be adjusted to make up this difference.

NOTE: Since the cutterhead is of a helical design, care must be taken to make the measurements at the same spot on the either end of the head. This may require that the cutterhead be rotated so that the gauge block comes in contact with either the knife inserts or body, same as was used on the first measurement taken.

ADJUSTMENTS

ADJUSTING THE PLANER TABLE

1. The planer table is attached to the cabinet and move vertically by four Threaded Spindles, or posts (#131, FIG. 24, A). At the base of the spindles, there are positioning Plates (#141, B). Next to the spindle ends, there are four Set Screws (#140A, C) that can be adjusted to slightly raise or lower an end of the planer table so that it will be parallel with the cutterhead.
2. Slightly loosen the four set screws at the corners of the base plate. Depending on which side of the planer's table needs to be raised, turn the set screws at that side of the base to raise the base/table.
3. Repeat measuring with the gauge block and making adjustments until the table is parallel with the cutterhead.
4. Remove the gauge block from the mouth of the planer and check all parts to confirm the machine is ready for use.

ADJUSTING THE FEED ROLLERS

The Infeed (#138) and Outfeed (#136) Rollers are pre-set by the factory to align parallel with the cutterhead and knife inserts. These spring loaded rollers are set just below the cutterhead, so that they engage the lumber and move it through the planer. Should an adjustment be required to increase or decrease the amount of downward pressure they exert on the lumber, the following steps are needed.

1. The outfeed jointer table and the fence needs to be removed, and the dust hood lifted up and pivoted back onto the cutterhead to gain access inside of the planer. See page 14, step 2 and FIG. 22 on this process.
2. Under the Feed Rollers, the long Hex Head Bolts (#147, D) hold the compression Springs (#145, E) in place, and control the pressure the rollers exert onto the lumber being moved through the planer for surfacing. The bolts can be tightened or loosened with a 13mm wrench. FIG. 25.
 - By tightening the bolts, UP the frame, the spring is compressed and the downward pressure of its roller is increased upon the lumber being fed through the planer.
 - By loosening the bolts, DOWN the frame, the spring compression is reduced, and its rollers exert less pressure down onto the lumber.
3. Once the rollers are set, the machine is ready for use.

ADJUSTING THE CUTTERHEAD GUARD

The Guard Bar (#207, A) must be covering the cutterhead's sharp knives at all time to keep you safe during jointing.

- Adjust the height of the cutterhead guard, with the Guard Setting Lever (#226, FIG. B, B).
- Adjust and lock the Guard (B) in place over the cutterhead knives with the Clamping Lever (#208, C). The guard's forward plastic, spring end will exert slight pressure against workpieces when used in jointing mode.

⚠ WARNING THE MACHINE MUST NOT BE PLUGGED IN AND THE POWER SWITCH MUST BE IN THE OFF POSITION UNTIL ALL ADJUSTMENTS ARE COMPLETE.

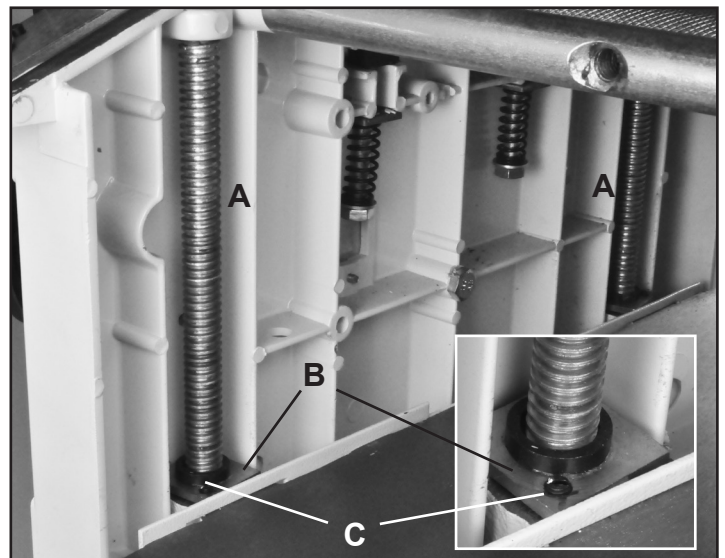

FIG. 24

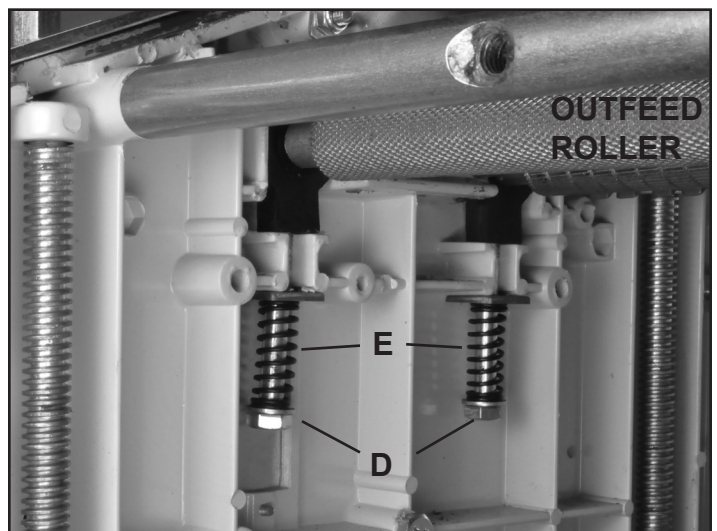

FIG. 25

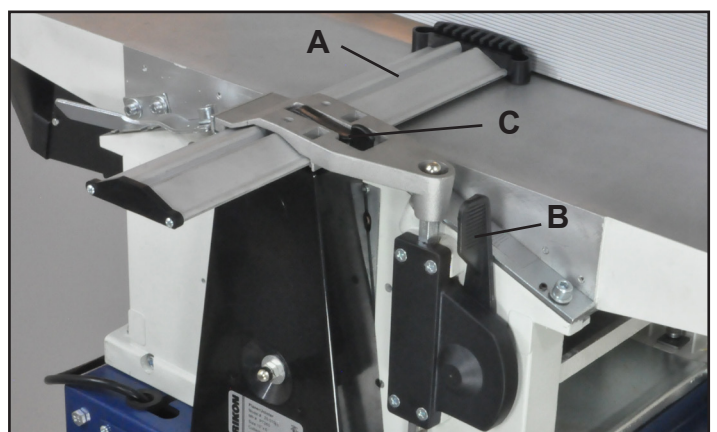

FIG. B

ADJUSTMENTS

ADJUSTING THE CUTTERHEAD

The Cutterhead that holds the knife inserts is fastened to the machine's cabinet, and is not adjustable. Based on the position of this main component of the machine, all of the other parts - rollers and tables - are then pre-set by the factory to align with the cutterhead. Should any of the tables or rollers get out of parallel with the cutterhead, they can be adjusted separately following the instructions in this manual.

ROTATING OR REPLACING KNIFE INSERTS

This machine has a helical cutterhead with four rows of carbide knife inserts. Each of the 44 inserts on the cutterhead are indexed and have four sharpened sides. If the knives become dull, or one becomes nicked, simply loosen the retaining screws with the supplied star head screwdriver, lift up and rotate the inserts to a new sharpened edge. No setting is required, as the cutterhead has been machined to automatically index and set the inserts in proper position for use. When all four sides of an insert are dull, the insert can be easily removed and a new carbide insert placed in the location. To rotate or remove an insert:

1. Unplug power cable.
2. Remove the Screw (#193), that holds the Insert in the cutterhead, and the Insert knife (#192). FIG. 26.
3. While the insert is removed, clean any resin buildup or trapped dust from the surfaces of the cutterhead with a suitable solvent. A tooth brush works well for safe cleaning around the sharp inserts. Any accumulated dust can affect the seating of the insert in the cutterhead.
4. Rotate the insert so that a new sharpened edge is in position. The inserts have a indication mark on their top surface corner, so that you can reference the positioning of the insert's dulled or sharpened edges. FIG. 26, 27, 28.
5. Tighten the insert's set screw to lock the insert back in position. DO NOT overtighten the screw or damage to the insert may result. Torque to 50-55 in/lbs.
6. Plug in the power cable when you are ready to resume jointing and planing.

ON/OFF SWITCH

The planer is equipped with a standard, push button ON/OFF safety switch (#302A, FIG. 29). Push the top green button to start the planer. There should be a 'click' to indicate the 'on' contact is made. Push the lower red button paddle switch to stop the planer.

NOTE: When working on the planer, the machine should always have the red, OFF button engaged and the cord un-plugged from the power source.

⚠ WARNING THE MACHINE MUST NOT BE PLUGGED IN AND THE POWER SWITCH MUST BE IN THE OFF POSITION UNTIL ALL ADJUSTMENTS ARE COMPLETE.

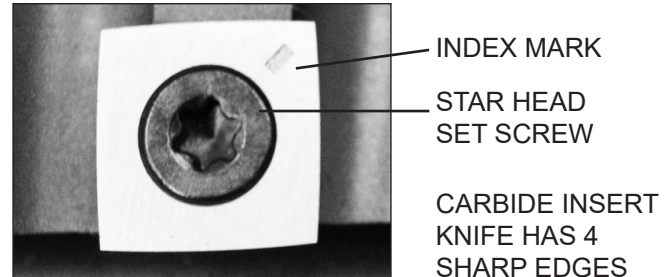

FIG. 26

⚠ CAUTION Wear gloves when changing knife inserts to avoid the risk of personal injury by cuts that may result from touching the sharp edges!

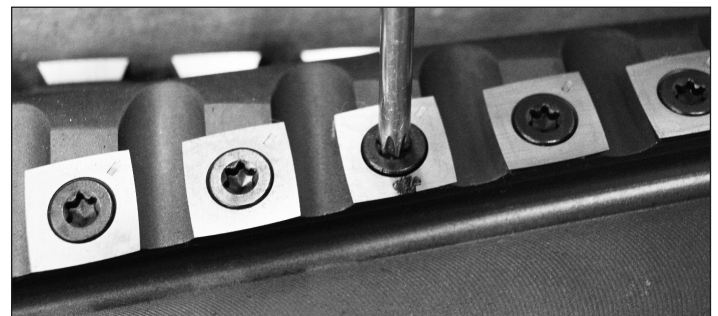

FIG. 27

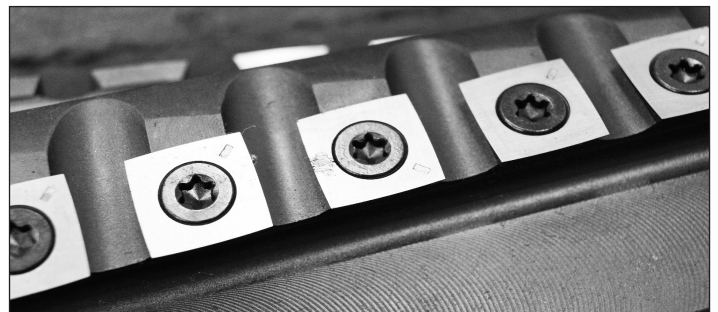

FIG. 28

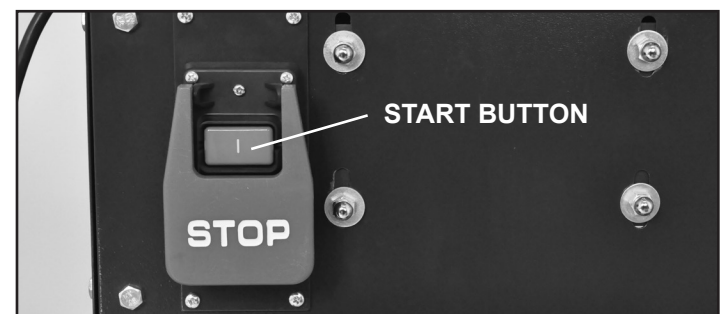

FIG. 29

ADJUSTMENTS

ADJUSTING DRIVE BELTS

The cutterhead drive belt and the feedgear drive belts need to be checked periodically and retightened if necessary. Belts will stretch with use, especially when they are new and are breaking in. Both drive belts are located behind the machine's front and rear covers. FIG. 30 & 31. To inspect, adjust or change the drive belts:

1. Make sure that the planer/jointer's switch is turned off, and the plug is disconnected from the power source.
2. Raise the cutterhead guard to remove the front cover, then unscrew the rear cover. This will expose both sides of the machine and its motor, pulleys and belts.

TENSIONING THE DRIVE BELTS

3. Check the *Cutterhead Drive Belt* (#309, FIG. 30, A) tension with thumb pressure. The drive belt should not give more than 3/8" in the center. FIG. 32.

4. From the front of the machine, loosen the four Nuts (#313, FIG. 30, B) that secure the motor in place. Lift the motor to slacken the tension on the drive belt, or move it down to increase the belt tension.

5. When the belt tension is correct, tighten the motor mounting nuts that were done in step 4.

6. The *Feed Roller Belt* (#256, FIG. 31, C) requires no adjustments. Its elasticity automatically applies tension.

7. The *Feed Roller Chain* (#248, FIG. 31, D) is automatically tensioned with the Spring Assembly (#246, 247, 249, E) and requires no adjustments.

NOTE: While the side panel and cutterhead cover are open, remove any chips and dust that may have accumulated with a dust collector or brush.

8. When all belts have been checked and any maintenance has been done, replace the side panel and belt cover and secure them in position with the screws.

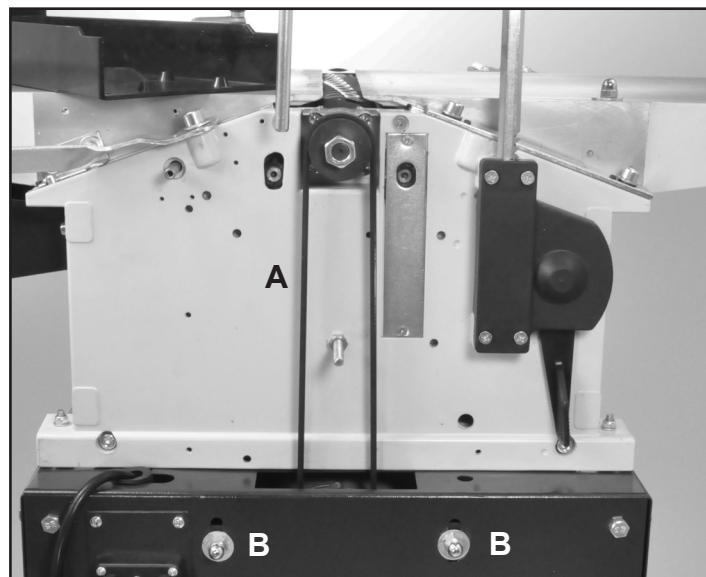

FIG. 30

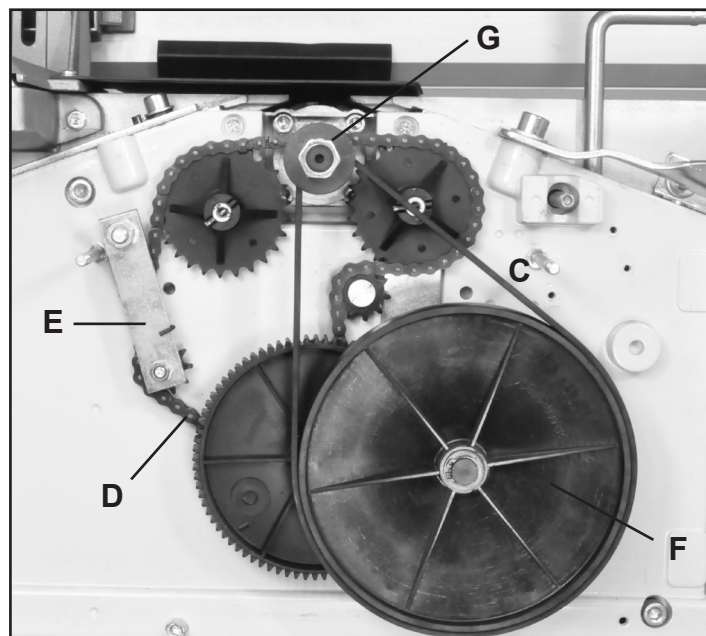

FIG. 31

REPLACING THE DRIVE BELTS

1. To replace the *Drive Belt* (#309), follow the same steps, #3-5 above. Loosen the tension until the belt can be easily removed from the Motor Pulley (#311) and Cutterhead Pulley (#235). Once removed, reverse the steps to install and re-tension the new belt on the pulleys. FIG. 30.

2. To replace the *Feed Roller Belt* (#256, FIG.31, C), simply stretch the elastic belt and position it over the large, Flat Belt Pulley (#257, F), then the Cutterhead Shaft (G).

3. When all work on the belts has been done, replace the side covers and secure them in position with their screws.

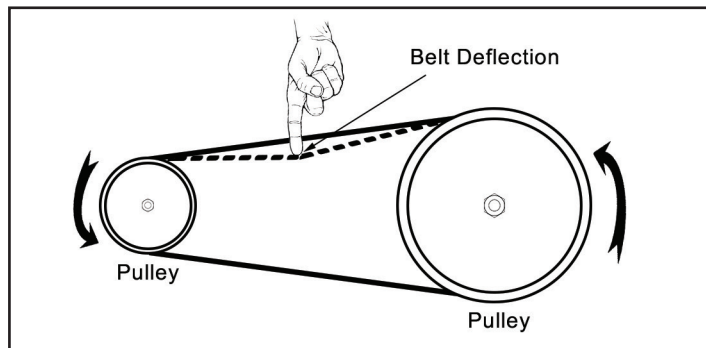

FIG. 32

OPERATION

⚠ WARNING Before turning on the machine, review the safety precautions listed on pages 3 to 6. Make sure that you fully understand the features, adjustments and capabilities of the machine that are outlined throughout this manual.

JOINTER OPERATION

The function of the jointer is to surface plane flat, one side or edge of a board/workpiece.

To use the jointer:

1. The chip ejection hood should be positioned under the jointer's outfeed table, inside of the planer's cavity.
2. Connect your Dust Collector Hose to the Dust Port, then raise the planer bed to secure the chip ejection hood in position for jointing. FIG. 34.

⚠ WARNING It is extremely important that a dust collection system is used with this planer to eliminate harmful airborne dust, prevent the build-up of chips that may jam the roller system in the cutterhead, and to keep the working area clean of debris.

NOTE: Workpiece dimensions for jointing:

- Length: use a push stick to feed boards shorter than 12" ; for lumber over 60" use support rollers.
- Width: maximum 10".
- Thickness: minimum 1/4". The use of push blocks is necessary when face planing thin material.
- Depth of Cut: maximum 1/8". Multiple cuts of 1/16" or less, produce better finish results

Place the workpiece on top of the right, infeed table.

- The workpiece will be cut on its underside by the rotating cutterhead knives.
- When jointing, the feeding direction of the workpiece is right-to-left over the cutterhead. FIG. 33.

1. Assume the proper operating position: stand to the side of the infeed table with feet apart for stability through the whole cutting process. FIG. 33.
2. Set the jointer fence position and angle as required.
3. Set the depth of cut / thickness.
4. Place the workpiece against the jointer fence for support through the cutting action. FIG. 35.
5. Adjust the cutterhead guard for user protection.

NOTE: For jointing the edge of a board, set the blade guard to the width of workpiece. The plastic spring on the end of the blade guard should exert a slight pressure

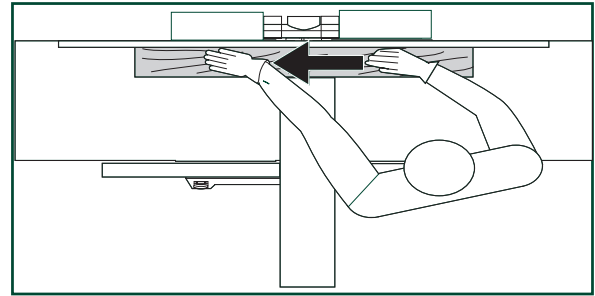

FIG. 33

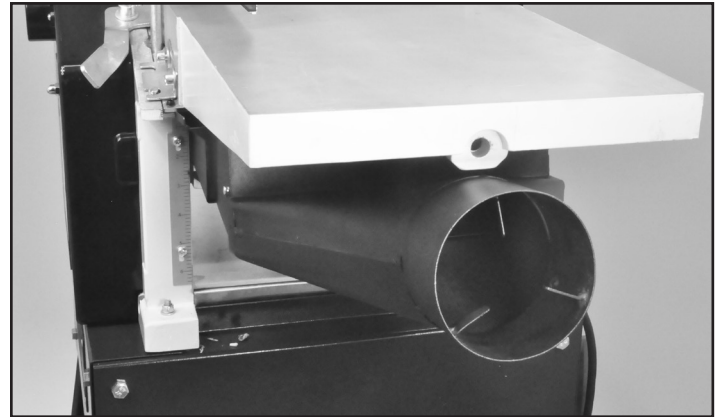

FIG. 34

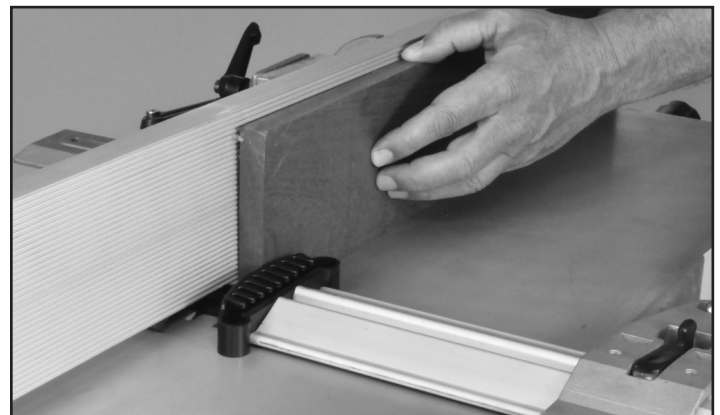

FIG. 35



FIG. 36

Continued on page 19

OPERATION

Jointer Operation - Continued from page 18

against the workpiece. Lock blade guard in place before starting the machine. Push the workpiece slowly and steady against cutterhead. Ensure that the fence is set at true 90° (or any other angle required (see page 13) and workpiece is kept flush against fence.

- For planing the face of a plank or workpieces, lower the cutterhead guard to just above the workpiece - approximately 1/8" (3mm).

6. Turn the machine on and place the workpiece on the infeed table. Feed the workpiece toward the cutterhead, exerting downward pressure until the workpiece clears the cutterhead on the outfeed table side. Always keep your hands away from the cutterhead to avoid any accidents.

- Run boards at different positions along the width of the cutterhead to utilize the full length of the cutting knives. Jointing in one area of the cutterhead, will quickly dull the knives in that area.

PLANER OPERATION

Thickness planing is used to reduce a workpiece with one already surface planed surface to a desired thickness.

To use the planer;

1. Remove the fence assembly, outfeed table, slide the cutterhead guard clear of table, and set the guard to its highest position.
2. Swing the chip ejection hood up and over the cutterhead and secure it in place by lowering the blade guard onto it for added security. FIG. 37.
3. Attach your Dust Collector Hose to the dust hood's port.

! WARNING The chip ejection hood is the cutterhead guard when the machine is set up for thickness planing. Never operate the machine without the chip ejection hood in place and properly secured.

! WARNING It is extremely important that a dust collection system is used with this planer to eliminate harmful airborne dust, prevent the build-up of chips that may jam the roller system in the cutterhead, and to keep the working area clean of debris.

To use the planer:

- The board surface that has been already jointed flat rests down onto the planer's table.
- The board will be cut on its upper surface by the cutterhead as it passes through the planer.
- When planing, the feeding direction of the workpiece is left-to-right under the cutterhead. FIG. 38, 39.

NOTE: Workpiece dimensions for planing;

- Length: minimum 12"; for lumber over 60" use roller supports.
- Width: maximum 10".
- Thickness: minimum 1/4"; maximum 6-1/4".
- Depth of Cut: maximum 1/8". Multiple cuts of 1/16" or less, produce better finish results.

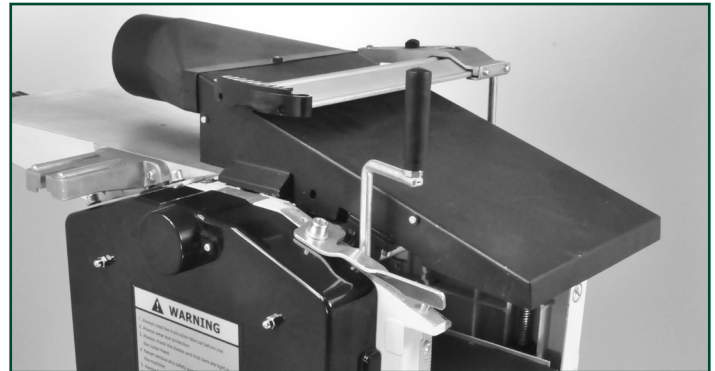

FIG. 37

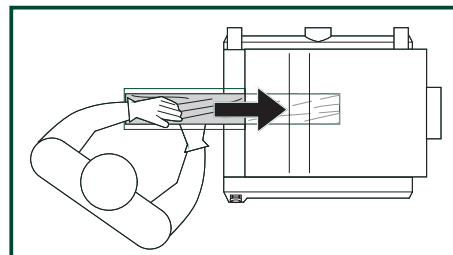

FIG. 38

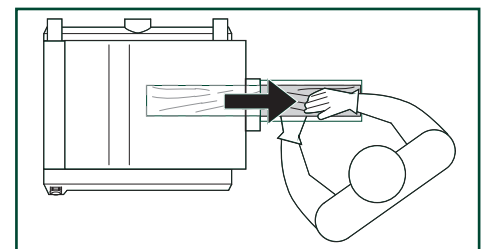

FIG. 39

1. To feed the workpiece into the machine, assume proper operating position, FIG. 38. Stand offset to one side of the feed opening to avoid any kick-back, should it occur. Do not push the lumber once the infeed roller has been engaged. Let the infeed roller move the workpiece into the planer at its own pace.

2. To remove the workpiece from the machine, position yourself offset to one side of the outfeed opening. FIG. 39. Do not pull the lumber as it exits the machine. Let the outfeed roller move the workpiece out of the planer at its own rate, but support the lumber as it extends past the extension rollers, if needed.

continued page 20

OPERATION

Planer Operation - Continued from page 19

3. Set planing thickness. Measure your board's thickness and set the planer to this measurement, or 1/16" under this figure. For the initial pass, you do not want to take off an excessive amount of stock (over 1/8"), or damage to the planer may result. Repeated passes through the planer will get you to your final desired board thickness. See page 14.

4. Feed boards slowly and straight into the planer. Boards will be automatically fed through the planer by the infeed and outfeed rollers.

- Guide workpieces straight into and through the planer. The cutting action of the cutterhead may try to turn a board being surfaced, so slight controlling of the board may be necessary. Do not push the board forward, let the planer's rollers automatically move the board through the machine.

5. Remove the board from the planer. Ref: Step 2, Do not pull the lumber as it exits the machine. Let the out-feed roller move the workpiece out of the planer at its own rate, but support the lumber as it extends past the extension rollers, if needed.

- Make sure that there are no loose knots, nails, staples, dirt or foreign objects in the wood to be planed.

- Surface wood in the same direction of the grain, not across the grain. Never plane end cuts or end grain.

- Do not plane boards that are less than 12" long. Short boards should be planed end to end with other boards to prevent kick-back and snipe.

- Boards longer than 60" should have additional support as they enter and exit the planer, so that they do not tip up or down, causing snipe on the ends.

- Run boards through the planer at different positions along the width of the bed to utilize the full length of the cutting knives. Planing only in the center, or through one side of the planer, will quickly dull the knives in that area.

- To thickness plane stock with surfaces are not parallel, use suitable feeding aids (make fitting templates).

SNIPE

The term 'snipe' refers to the depression that may occur at the front or rear of a board during planing. It is caused by uneven pressure on the cutterhead when a board is fed into the planer, or when exiting. FIG. 40.

Avoid snipe by keeping your lumber firmly down onto the planer bed at the beginning of the cut, and also at the end of the cutting action, as the lumber exits the planer.

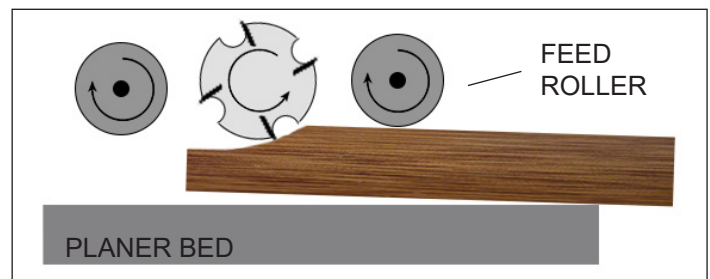

FIG. 40

SQUARING A WORKPIECE EXAMPLE

1. FIG. 41, A - On the jointer, surface side 1 flat.

2. B - After surfacing side 1, turn the workpiece 90° so that side 1 now rests against the fence. Joint side 2 flat. The workpiece will now have two sides at 90° to each other.

3. C - Using the planer, run the workpiece with side 1 positioned flat against the planer bed. The opposite side 3 can then be cut, and it will then be parallel to side 1.

4. D - Position side 2 flat against the planer bed, and side 4 will be planed flat, and be parallel to side 2.

The workpiece will now be square, having four flattened surfaces and four square edges.

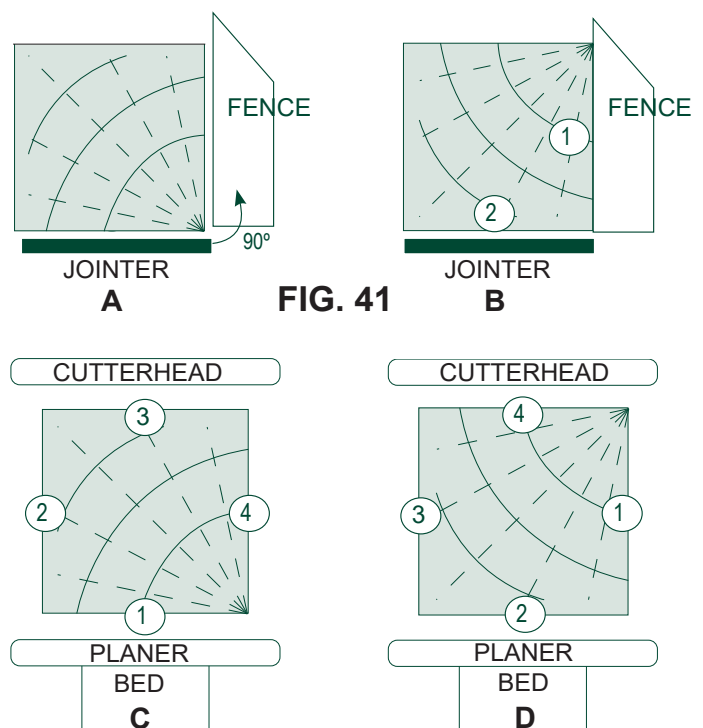

FIG. 41

MAINTENANCE

⚠ WARNING: Turn the power switch “OFF” and disconnect the plug from the outlet prior to adjusting or maintaining the machine. DO NOT attempt to repair or maintain the electrical components of the motor. Contact a qualified service technician for this type of maintenance.

1. Before each use:
 - Check the power cord and plug for any wear or damage.
 - Check for any loose screws or hardware.
 - Check the area to make sure it is clear of any misplaced tools, lumber, cleaning supplies, etc. that could hamper the safe operation of the planer.
2. To avoid a build-up of wood dust, regularly clean all parts of the machine using a soft cloth, brush or compressed air. A general cleaning should be done after every use to avoid future problems and ensure the machine is in ready condition for the next time it is used.

WARNING: If blowing sawdust, wear proper eye protection to prevent debris from blowing into eyes.

3. Check the knives to make sure that they are not loose from the cutterhead, dull or nicked. Making sure that they are in proper operating condition will ensure that the quality of your surfaced lumber will be the best possible.
4. Lubricate all bearing points and chains regularly with a few drops of light motor oil. Cutterhead ball bearings are lifetime lubricated, sealed, and do not need any further care. Keep the drive belts free of oil and grease.
5. Clean the planer bed columns on a regular basis to prevent the build-up of wood chips and dust. Treat the posts with a dry lubricant spray. Do not use ordinary oil which will collect dust and hamper the operation of the machine.

6. Keep the jointer and planer tables free of resin and rust. Clean them regularly with a non-flammable solvent, then coat with a light film of dry lubricant spray, or wax, to enhance passage of workpiece on/over the tables.

WARNING: When cleaning or working on the tables, avoid the risk of personal injury by cuts that may result from touching the knife inserts' sharp edges! Lower the planer table to its maximum 'down' position, so that there is ample distance between the table and the cutterhead's sharp inserts for your safety.

7. Clean the feed rollers with a soft rag, and non-flammable solvent if there is resin build-up on the metal rollers. Do not apply solvents on a 'rubber' coated roller, as it may affect the material. Be careful to keep hands away from the sharp cutterhead knife inserts. Do not apply any lubricant to the rollers as they must 'grab' the lumber to move it through the planer and so must not slip.
8. Check the anti-kickback fingers to make sure that they are clean of any dust or resin, so that they swing freely. Lubricate only with a dry lubricant, never oil or grease.
9. Check the belt tension after the first 3-5 hrs. of operation to ensure that the belts have not become stretched and loose from their 'breaking in' use. See page 17 for instructions.

WIRING DIAGRAM

⚠ WARNING: This machine must be grounded. Replacement of the power supply cable should only be done by a qualified electrician. See page 5 for additional electrical information.

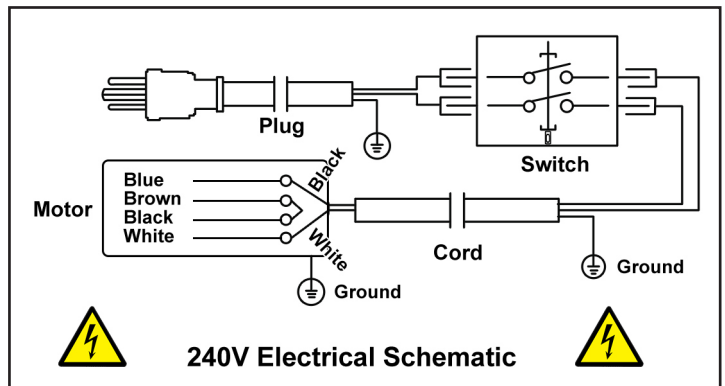
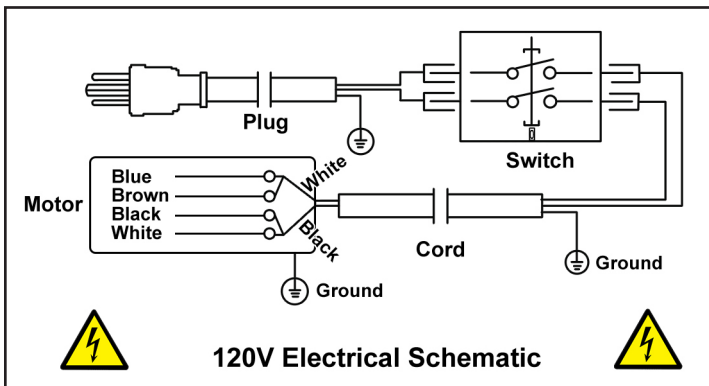

For 120V wiring; connect the black & white motor terminal wires to the black switch wire lead, and connect the blue & brown terminal wires to the white switch wire lead. Disregard the red wires that lead to the capacitor.

For 240V wiring; tie the black & brown terminals together, connect the white motor terminal wire to the white switch wire lead, and connect the blue motor terminal wire to the black switch wire lead. Disregard the red wires that lead to the capacitor.

TROUBLESHOOTING



FOR YOUR OWN SAFETY, ALWAYS TURN OFF AND UNPLUG THE MACHINE BEFORE CARRYING OUT ANY TROUBLESHOOTING.

SYMPTOM	POSSIBLE CAUSES	SOLUTIONS
Machine will not start.	<ol style="list-style-type: none"> 1. No power 2. Blown fuse 3. ON / OFF switch not functioning 4. Motor failure 	<ol style="list-style-type: none"> 1. Check power source, plug and wiring. 2. Check fuse, replace if it is blown. 3. Check position of the switch. Contact local dealer for repair or replacement. 4. Inspect motor for failed components. Contact Dealer for repair or replacement.
Circuit Breakers trip and /or Fuses are blown	<ol style="list-style-type: none"> 1. Wrong circuit size for the machine 2. Motor is overloaded under strain from taking too heavy of cut 3. Use of an extension cord 	<ol style="list-style-type: none"> 1. Check circuit/fuse rating and amps of the motor. Install CORRECT rated breaker/fuse. 2. Take lighter cuts in planing lumber. 3. No extension cord, or use heavier gauge cord.
Machine bogs down in the cut	<ol style="list-style-type: none"> 1. Excessive depth of cut 2. Feed rate is too fast 3. Knives are dull 	<ol style="list-style-type: none"> 1. Decrease depth of cut. 2. Reduce feed rate. 3. Replace or sharpen knives.
Cutting and planer feed rate is not constant	<ol style="list-style-type: none"> 1. Belts are loose 2. Chips and dust build-up on parts 	<ol style="list-style-type: none"> 1. Check pulleys and belts for tension & wear. 2. Unplug machine and clean all parts.
TROUBLESHOOTING THE JOINTER		
Jointer fence is not accurate at 90° or 45°	<ol style="list-style-type: none"> 1. Fence stops are not properly adjusted 2. Locking handles are loose 	<ol style="list-style-type: none"> 1. Readjust the fence stops. 2. Check all handles to make sure that they are properly tightened before starting the machine.
'Chatter' marks on lumber	<ol style="list-style-type: none"> 1. Feed rate is too fast 	<ol style="list-style-type: none"> 1. Slow the feed rate down.
Cutterhead slows down when jointing	<ol style="list-style-type: none"> 1. Feed rate is too fast 2. Downward pressure on the cutterhead knives is too great 	<ol style="list-style-type: none"> 1. Slow down feeding the wood over the cutterhead. 2. Apply less downward pressure
Small raised lines are running along the surface	<ol style="list-style-type: none"> 1. Knives are nicked or broken 	<ol style="list-style-type: none"> 1. Rotate insert knives to new sharp edges.
Jointed stock is concave on the back end of the board	<ol style="list-style-type: none"> 1. Knives are set higher than the outfeed table 	<ol style="list-style-type: none"> 1. Raise the outfeed table level with the cutterhead & knives.
Jointed stock is concave on the front end of the board	<ol style="list-style-type: none"> 1. Outfeed table is set higher than the knives 	<ol style="list-style-type: none"> 1. Lower the outfeed table level with the cutterhead & knives.
Stock is concave in the middle of the board	<ol style="list-style-type: none"> 1. Table is out of level 	<ol style="list-style-type: none"> 1. Raise the table ends.
Milled surface is torn - also called 'chip out' or 'tear out'	<ol style="list-style-type: none"> 1. Cutting against the grain 2. Cut is too deep 3. Knives are dull 	<ol style="list-style-type: none"> 1. Cut with the grain. For figured woods, take shallow cuts to minimize tear out. 2. Reduce cutting depth to 1/16" or less. 3. Rotate insert knives to new sharp edges.

TROUBLESHOOTING

SYMPTOM	POSSIBLE CAUSES	SOLUTIONS
TROUBLESHOOTING THE JOINTER - continued		
Milled surface grain is rough, raised or fuzzy	<ol style="list-style-type: none"> 1. Lumber has a high moisture content 2. Knives are dull 	<ol style="list-style-type: none"> 1. Reduce the moisture content by drying it, or switch to other properly seasoned lumber. 2. Rotate insert knives to new sharp edges.
Milled surface is glossy	<ol style="list-style-type: none"> 1. Cutting depth is too shallow 2. Knives are dull 3. Feed rate is too slow 	<ol style="list-style-type: none"> 1. Increase depth of cut slightly. 2. Rotate insert knives to new sharp edges. 3. Increase feed rate.
TROUBLESHOOTING THE PLANER		
Poor feeding of lumber through the planer	<ol style="list-style-type: none"> 1. Drive belt is worn or broken 2. Drive belt tension spring is broken 3. Lumber sticking on planer's table 4. Feed rollers not applying enough pressure on lumber 	<ol style="list-style-type: none"> 1. Check and replace as necessary. 2. Check tension and/or replace the spring. 3. Clean the table and apply silicone based lubricant to reduce friction. 4. Adjust the feed roller pressure.
Not planing lumber to a uniform thickness	<ol style="list-style-type: none"> 1. Planer table is not level to cutterhead 	<ol style="list-style-type: none"> 1. Adjust table and/or cutterhead as needed.
Board thickness does not match scale markings	<ol style="list-style-type: none"> 1. Depth of cut scale not set correct 	<ol style="list-style-type: none"> 1. Adjust scale to match board thickness
Small raised lines are running along the surface	<ol style="list-style-type: none"> 1. Knives are nicked or broken 	<ol style="list-style-type: none"> 1. Rotate insert knives to new sharp edges.
Snipe on board ends (NOTE: Snipe can be reduced, but not fully eliminated)	<ol style="list-style-type: none"> 1. Feed rollers not set properly 2. Lumber not supported when fed into or exiting the planer 3. Short boards not butted 	<ol style="list-style-type: none"> 1. Adjust feed roller height for applying pressure onto lumber to keep flat on table. 2. Support long boards with roller stands. 3. Run boards butt end to end through planer
Planed surface is torn - also called 'chip out' or 'tear out'	<ol style="list-style-type: none"> 1. Cutting against the grain 2. Cut is too deep 3. Knives are dull 	<ol style="list-style-type: none"> 1. Cut with the grain. For figured woods, take shallow cuts to minimize tear out. 2. Reduce cutting depth to 1/16" or less. 3. Rotate insert knives to new sharp edges.
Planed surface grain is rough, raised or fuzzy	<ol style="list-style-type: none"> 1. Lumber has a high moisture content 2. Knives are dull 	<ol style="list-style-type: none"> 1. Reduce the moisture content by drying it, or switch to other properly seasoned lumber. 2. Rotate insert knives to new sharp edges.
Planed surface is glossy	<ol style="list-style-type: none"> 1. Cutting depth is too shallow 2. Knives are dull 3. Feed rate is too slow 	<ol style="list-style-type: none"> 1. Increase depth of cut slightly. 2. Rotate insert knives to new sharp edges. 3. Increase feed rate.

For parts or technical questions contact: techsupport@rikontools.com or 877-884-5167.

PARTS DIAGRAM

FRAME & TABLE ASSEMBLY

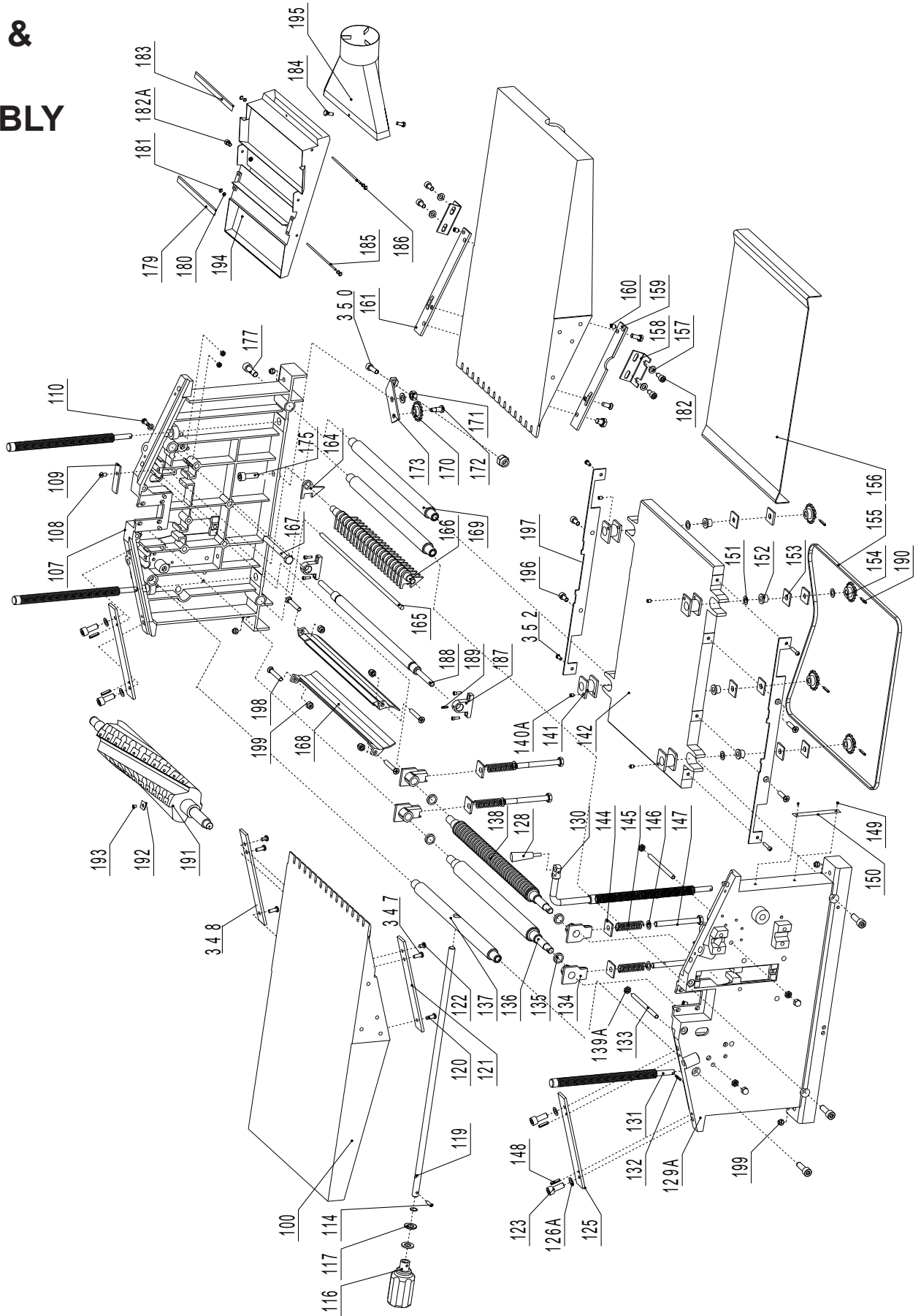

NOTE: Please reference the Manufacturer's Part Number when calling for Replacement Parts. For Parts under Warranty, the Serial Number of your machine is required.

PARTS LIST

KEY NO.	DESCRIPTION	MFG. PART NO.	KEY NO.	DESCRIPTION	MFG. PART NO.
100	Planing Table	P25-010-100	157	Washer – 6mmØ	P25-010-157
107	Side Panel	P25-010-107	158	Setting Bracket	P25-010-158
108	Pan Head Screw – M5 x 12mm	P25-010-108	159	Guide Rail – left	P25-010-159
109	Square Washer	P25-010-109	160	Guide Screw	P25-010-160
110	Hex Nut – M8	P25-010-110	161	Guide Rail – right	P25-010-161
114	Roll Pin	P25-010-114	164	Recoil Lock Segment	P25-010-164
116	Knob	P25-010-116	165	Recoil Lock Bar – 6mmØ x 286mm	P25-010-165
117	Washer – 23mm x 10mm	P25-010-117	166	Recoil Lock Bar – 10.7mmØ x 286mm	P25-010-166
119	Threaded Rod – 450mm	P25-010-119	167	Hex Head Screw – M8 x 80mm	P25-010-167
120	Hex Head Screw – M6 x 16mm	P25-010-120	168	Chip Guide Plate	P25-010-168
121	Spacer Strip - left	P25-010-121	169	Spacer Shaft	P25-010-169
122	Hex Head Screw – M6 x 11mm	P25-010-122	170	Chain Tension Sprocket - Z=15 T=6	P25-010-170
123	Hex Head Screw – M8 x 16mm	P25-010-123	171	Hex Nut - M6	P25-010-171
125	Guide Rail	P25-010-125	172	Threaded Bolt – M13 x 22mm	P25-010-172
126A	Washer - M8	P25-010-126A	173	Chain Tension Plate	P25-010-173
128	Crank Handle	P25-010-128	175	Hex Head Screw – M8 x 25mm	P25-010-175
129A	Side Panel - right	P25-010-129A	177	Hex Head Screw – M8 x 25mm	P25-010-177
130	Planing Table Adjusting Spindle	P25-010-130	179	Baffle Plate	P25-010-179
131	Planing Table Spindle	P25-010-131	180	Flat Washer	P25-010-180
132	Grooved Dowel Pin	P25-010-132	181	Split Washer	P25-010-181
133	Hex Head Screw – M6 x 80mm	P25-010-133	182A	Hex Cap Screw - M6 x 12mm	P25-010-182A
134	Glide Bracket	P25-010-134	183	Baffle Plate	P25-010-183
135	Washer – 12mm Ø	P25-010-135	184	Hex Bolt - M6 x 10	P25-010-184
136	Outfeed Roller – smooth	P25-010-136	185	Shaft	P25-010-185
137	Spacer Shaft with Tapped Hole	P25-010-137	186	Shaft	P25-010-186
138	Infeed Roller – coarse	P25-010-138	187	Base	P25-010-187
139A	Hex Nut - M6	P25-010-139A	188	Supporting Axle	P25-010-188
140A	Cap Screw – M5 x 6mm	P25-010-140A	189	Roll Pin	P25-010-189
141	Spindle End Nut	P25-010-141	190	Roll Pin	P25-010-190
142	Planing Table with Pointer	P25-010-142	191	Helical Cutterhead & Shaft	P25-010H-191
144	Shim with Hole - 8.1	P25-010-144	192	Cutterhead Insert Knife	P25-010H-192
145	Pressure Spring	P25-010-145	193	Screw	P25-010H-193
146	Washer – 8mm Ø	P25-010-146	194	Dust Extraction Hood	P25-010-194
147	Hex Head Screw – M8 x 75mm	P25-010-147	195	Dust Port	P25-010-195
148	Roll Pin – M8 x 16mm	P25-010-148	196	Screw - M5 x 10mm	P25-010-196
149	Pan Head Screw - M4 X 8mm	P25-010-149	197	Plate	P25-010-197
150	Planing Table Scale	P25-010-150	198	Screw - M6 x 35mm	P25-010-198
151	Shim Ring	P25-010-151	199	Nut - M6	P25-010-199
152	Spindle Bushing	P25-010-152	347	Screw - M6 x 10mm	P25-010-347
153	Shim with Hole – 12.1	P25-010-153	348	Spacer - right	P25-010-348
154	Chain Sprocket - Z=15 T=6	P25-010-154	350	Hex Cap Screw - M6 x 28mm	P25-010-350
155	Roller Chain – pitch 6 – 210 links	P25-010-155	352	Pan Head Screw - M5 x 8mm	P25-010-352
156	Drive Chain Protection Plate	P25-010-156			

PARTS DIAGRAM

FENCE & DRIVE ASSEMBLY

NOTE: Please reference the Manufacturer's Part Number when calling for Replacement Parts. For Parts under Warranty, the Serial Number of your machine is required.

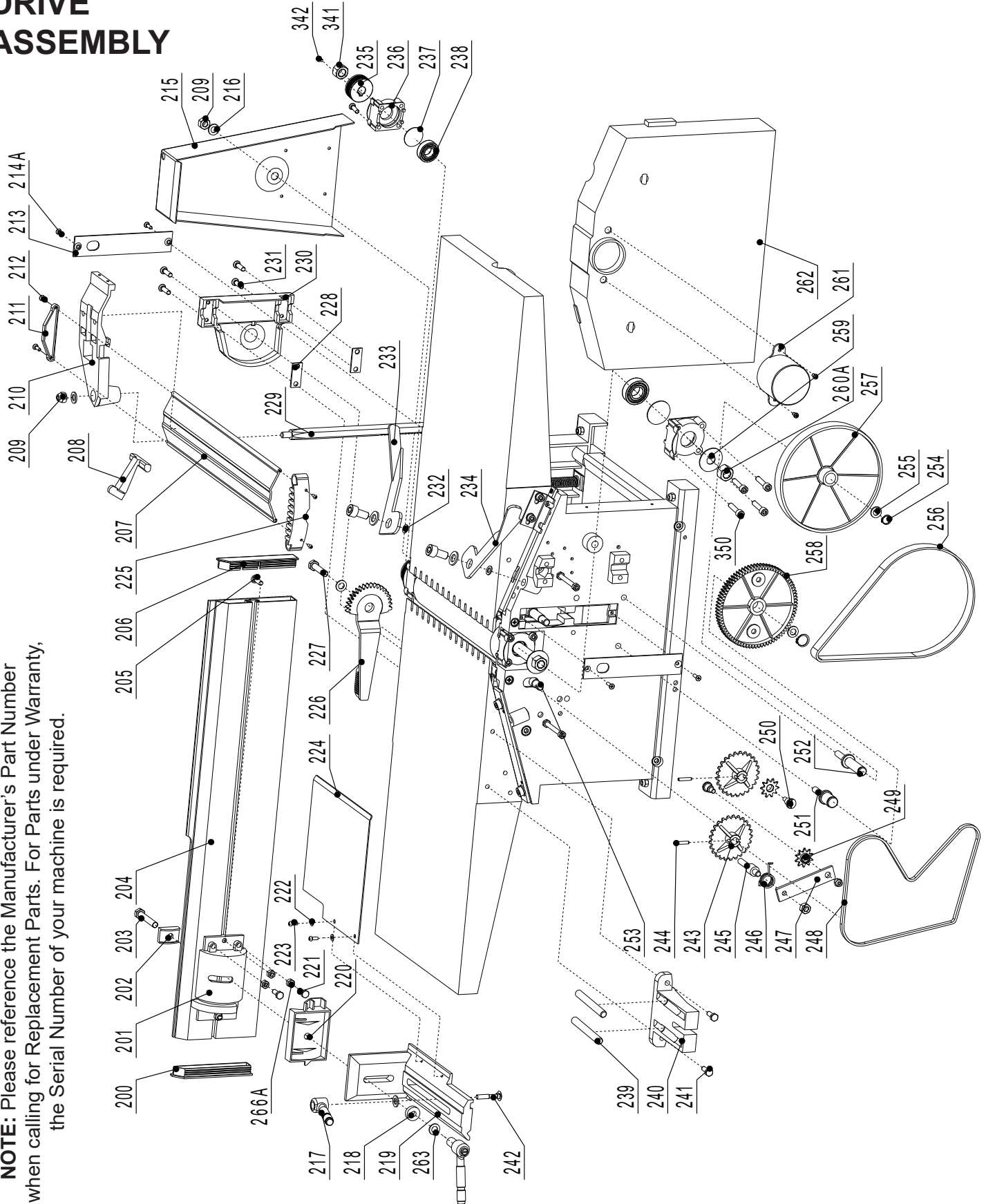

PARTS LIST

KEY NO.	DESCRIPTION	RIKON PART NO.	KEY NO.	DESCRIPTION	RIKON PART NO.
200	Fence End Cap – right	P25-010-200	234	Locking Lever - left	P25-010-234
201	Fence Bracket	P25-010-201	235	J-Belt Pulley – 5J x 42	P25-010-235
202	Glide Segment	P25-010-202	236	Bearing Cup	P25-010-236
203	Hex Head Screw – M8 x 50mm	P25-010-203	237	O-Ring – Ø40 x 2.65	P25-010-237
204	Fence Extrusion	P25-010-204	238	Grooved Ball Bearing - 6203	P25-010-238
205	Carriage Bolt – M6 x 20mm	P25-010-205	239	Guide Bar	P25-010-239
206	Fence End Cap – left	P25-010-206	240	Fence Carrier Support Bracket	P25-010-240
207	Cutter Guard	P25-010-207	241	Hex Head Screw – M6 x 20mm	P25-010-241
208	Guard Clamping Lever	P25-010-208	242	Carriage Bolt – M8 x 40mm	P25-010-242
209	Cap Nut – M8	P25-010-209	243	Chain Sprocket - Z=25 T=38	P25-010-243
210	Guard Support	P25-010-210	244	Roll Pin – Ø4mm x 20mm	P25-010-244
211	Guard End Cap	P25-010-211	245	Bolt - chain tensioner	P25-010-245
212	Pan Head Screw – St3.5 x 13mm	P25-010-212	246	Torsion Spring	P25-010-246
213	Side Panel Lid	P25-010-213	247	Chain Tensioning Plate	P25-010-247
214A	Pan Head Screw – M4 x 12mm	P25-010-214A	248	Roll Chain – pitch 8 – 74 links	P25-010-248
215	Drive Belt Cover	P25-010-215	249	Chain Sprocket - Z=10 T=8	P25-010-249
216	Washer – 8mmØ	P25-010-216	250	Bolt – Ø14mm x 20mm	P25-010-250
217	Ratchet Lever Handle – M8	P25-010-217	251	Bolt, short – Ø20mm x 64.5mm	P25-010-251
218	Plastic Washer – 20mmØ x 8mmØ	P25-010-218	252	Bolt, long – Ø20mm x 87mm	P25-010-252
219	Fence Carrier	P25-010-219	253	Retaining Ring – Ø8	P25-010-253
220	Guide Segment	P25-010-220	254	Retaining Ring – 16mm x 1mm	P25-010-254
221	Hex Head Bolt – M6 x 16mm	P25-010-221	255	Shim Ring – 16mm x 22mm	P25-010-255
222	Washer – 4mmØ	P25-010-222	256	Flat Belt	P25-010-256
223	Pan Head Screw – M4 x 8mm	P25-010-223	257	Flat Belt Pulley	P25-010-257
224	Fence Cover Plate	P25-010-224	258	Cam Wheel - Z=25 T=38	P25-010-258
225	PVC Pressure Spring	P25-010-225	259	Disk Spring – 34mm x 12.3mm	P25-010-259
226	Guard Setting Lever	P25-010-226	260A	Hex Nut – M14	P25-010-260A
227	Hex Screw – M10 x 16mm	P25-010-227	261	Spindle Cover	P25-010-261
228	Pressure Plate	P25-010-228	262	Gear Cover	P25-010-262
229	Guard Rod, Cogged, Hexagonal	P25-010-229	263	Flat Washer	P25-010-263
230	Gear Cover	P25-010-230	266A	Flat Washer	P25-010-266A
231	Countersunk Head Screw M6x20	P25-010-231	330	Knife Setting Gauge (not shown)	P25-010-330
232	Shim Ring	P25-010-232	341	Hex Nut - M12	P25-010-341
233	Locking Lever - right	P25-010-233	342	Flat Key	P25-010-342

PARTS DIAGRAM

MOTOR & CABINET

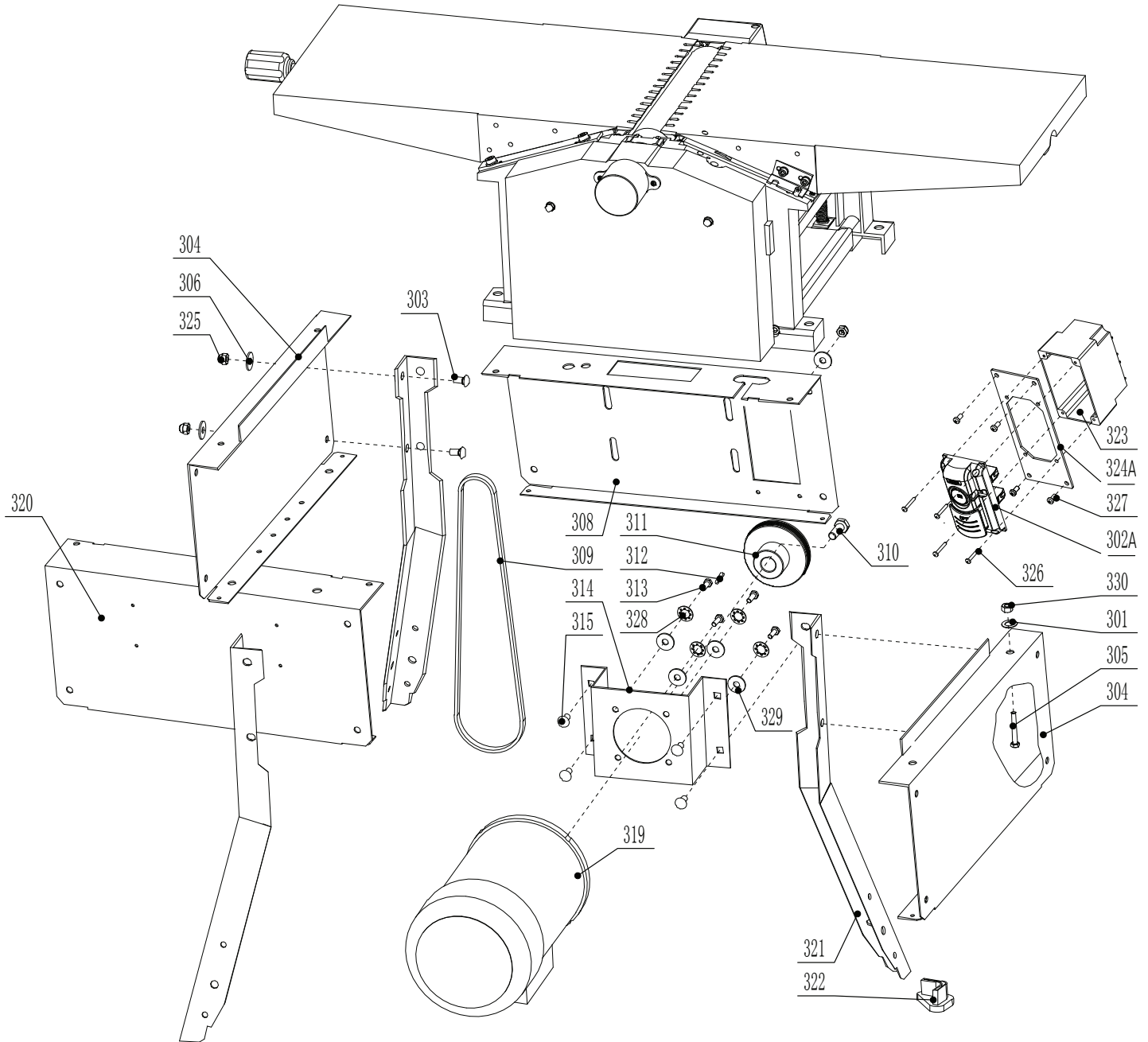

NOTE: Please reference the Manufacturer's Part Number when calling for Replacement Parts.
For Parts under Warranty, the Serial Number of your machine is required.

PARTS LIST

MOTOR & CABINET

KEY NO.	DESCRIPTION	MFG. PART NO.
301	Washer – 6.4mm	P25-010-301
302A	ON/OFF Switch	P25-010-302A
303	Hex Head Bolt – M8 x 16mm	P25-010-303
304	Side Panel	P25-010-304
305	Hex Head Bolt – M6 x 40mm	P25-010-305
306	Washer – 8mm	P25-010-306
308	Front Panel	P25-010-308
309	Poly-V-Belt – 5PJ864	P25-010-309
310	Hex Head Bolt – M8 x 20mm	P25-010-310
311	J-Belt Pulley – 5J x 90	P25-010-311
312	Key – A6 x 30mm	P25-010-312
313	Hex Head Cap Screw – M6 x 16mm	P25-010-313
314	Motor Carrier	P25-010-314
315	Carriage Bolt – M8 x 16mm	P25-010-315
319	Motor	P25-010-319
319A	Capacitor (not shown)	P25-010-319A
320	Rear Panel	P25-010-320
321	Stand Legs	P25-010-321
322	Rubber Floor Pads	P25-010-322
323	Switch Box	P25-010-323
324A	Switch Plate	P25-010-324A
325	Nut - M8	P25-010-325
326	Pan Head Screw	P25-010-326
327	Pan Head Screw	P25-010-327
328	Washer	P25-010-328
329	Flat Washer	P25-010-329

NOTE: Please reference the Manufacturer's Part Number when calling for Replacement Parts.
For Parts under Warranty, the Serial Number of your machine is required.

RIKON

POWER TOOLS®

5-Year Limited Warranty

RIKON Power Tools Inc. ("Seller") warrants to only the original retail consumer/purchaser of our products that each product be free from defects in materials and workmanship for a period of five (5) years from the date the product was purchased at retail. This warranty may not be transferred.

This warranty does not apply to defects due directly or indirectly to misuse, abuse, negligence, accidents, repairs, alterations, lack of maintenance or normal wear and tear. Under no circumstances will Seller be liable for incidental or consequential damages resulting from defective products. All other warranties, expressed or implied, whether of merchantability, fitness for purpose, or otherwise are expressly disclaimed by Seller. This five-year warranty does not cover products used for commercial, industrial or educational purposes. The warranty term for these claims will be limited to a two-year period.

This limited warranty does not apply to accessory items such as blades, drill bits, sanding discs, grinding wheels, belts, guide bearings and other related items.

Seller shall in no event be liable for death, injuries to persons or property, or for incidental, contingent, special, or consequential damages arising from the use of our products.

To take advantage of this warranty, proof of purchase documentation must be provided which has the date of purchase and an explanation of the complaint.

The Seller reserves the right to effect at any time, without prior notice, those alterations to parts, fittings, and accessory equipment which they may deem necessary for any reason whatsoever.

To register your machine online, visit RIKON at www.rikontools.com/warranty

To take advantage of this warranty, or if you have any questions, please contact us at 877-884-5167 or email warranty@rikontools.com



**For more information:
16 Progress Road
Billerica, MA 01821**

**877-884-5167 / 978-528-5380
techsupport@rikontools.com**

