

Benchttop Mortising Machine with X-Y Moving Table



CU72141729.01
CU72141730.01

Operator's Manual

Record the serial number and date of purchase in your manual for future reference.

Serial Number: _____ Date of purchase: _____

For technical support or parts questions, email techsupport@rikontools.com or call toll free at (877)884-5167

TABLE OF CONTENTS

Specifications.....	2
Safety Instructions	3 - 6
Getting To Know Your Machine	7
Contents of Package	7 - 8
Assembly	8 - 11
Adjustments.....	12 - 13
Operation	14
Maintenance	14
Troubleshooting	15
Electricals & Wiring Diagram	5 & 15
Parts Diagram	16
Parts List	17
Accessories	18
Notes	18
Warranty	19

SPECIFICATIONS

Motor	1/2 HP, TEFC
Motor Speed (no load).....	1,700 RPM
Volts	120 V
Amps, Hertz	3.6 A, 60 Hz
Chuck Capacity	1/2" (1.5 - 13 mm)
Chuck Type	Keyed
Chisel Shank Diameter	1" (3/4" & 5/8" bushings)
Chisel Range	1/4" to 5/8"
Chisel Stroke	4-3/4"
Table Size (Width x Depth)	7" x 8-1/4"
Maximum Clamping / Hold Down Width	3-7/8"
Maximum Height Under Chisel	5"
Table Movement Left to Right	6-5/8"
Table Movement Back to Front	4"
Fence Size	2 " Height x 7-1/16" Long
Overall Size (LxWxH).....	22-1/2" x 21-3/4" x 32-1/2"
Base Size (approx.)	10-3/4" Width x 12-1/2" Depth
Net Weight	86 lbs

NOTE: The specifications, photographs, drawings and information in this manual represent the current model when the manual was prepared. Changes and improvements may be made at any time, with no obligation on the part of Rikon Power Tools, Inc. to modify previously delivered units. Reasonable care has been taken to ensure that the information in this manual is correct, to provide you with the guidelines for the proper safety, assembly and operation of this machine.

SAFETY INSTRUCTIONS

IMPORTANT! Safety is the single most important consideration in the operation of this equipment. **The following instructions must be followed at all times.** Failure to follow all instructions listed below may result in electric shock, fire, and/or serious personal injury.

There are certain applications for which this tool was designed. We strongly recommend that this tool not be modified and/or used for any other application other than that for which it was designed. If you have any questions about its application, do not use the tool until you have contacted us and we have advised you.

SAFETY SYMBOLS



SAFETY ALERT SYMBOL: Indicates DANGER, WARNING, or CAUTION. This symbol may be used in conjunction with other symbols or pictographs.



Indicates an imminently hazardous situation, which, if not avoided, could result in death or serious injury.



Indicates a potentially hazardous situation, which, if not avoided, could result in death or serious injury.



Indicates a potentially hazardous situation, which, if not avoided, could result in minor or moderate injury.

NOTICE: Shown without Safety Alert Symbol indicates a situation that may result in property damage.

GENERAL SAFETY

KNOW YOUR POWER TOOL. Read the owner's manual carefully. Learn the tool's applications, work capabilities, and its specific potential hazards.

BEFORE USING YOUR MACHINE

To avoid serious injury and damage to the tool, read and follow all of the Safety and Operating Instructions before operating the machine.

1. Some dust created by using power tools contains chemicals known to the State of California to cause cancer, birth defects, or other reproductive harm.

Some examples of these chemicals are:

- Lead from lead-based paints.
- Crystalline silica from bricks, cement, and other masonry products.
- Arsenic and chromium from chemically treated lumber.

Your risk from these exposures varies, depending on how often you do this type of work. To reduce your exposure to these chemicals: work in a well ventilated area and work with approved safety equipment, such as those dust masks that are specially designed to filter out microscopic particles.

2. **READ** the entire Owner's Manual. **LEARN** how to use the tool for its intended applications.

3. **GROUND ALL TOOLS.** If the tool is supplied with a 3 prong plug, it must be plugged into a 3-contact electrical receptacle. The 3rd prong is used to ground the tool and provide protection against accidental electric shock. **DO NOT** remove the 3rd prong. See Grounding Instructions on the following pages.

4. **AVOID A DANGEROUS WORKING ENVIRONMENT.** **DO NOT** use electrical tools in a damp environment or expose them to rain.

5. **DO NOT** use electrical tools in the presence of flammable liquids or gases.

6. **ALWAYS** keep the work area clean, well lit, and organized. **DO NOT** work in an environment with floor surfaces that are slippery from debris, grease, and wax.

7. **KEEP VISITORS AND CHILDREN AWAY. DO NOT** permit people to be in the immediate work area, especially when the electrical tool is operating.

8. **DO NOT FORCE THE TOOL** to perform an operation for which it was not designed. It will do a safer and higher quality job by only performing operations for which the tool was intended.

9. **WEAR PROPER CLOTHING. DO NOT** wear loose clothing, gloves, neckties, or jewelry. These items can get caught in the machine during operations and pull the operator into the moving parts. The user must wear a protective cover on their hair, if the hair is long, to prevent it from contacting any moving parts.

10. **CHILDPROOF THE WORKSHOP AREA** by removing switch keys, unplugging tools from the electrical receptacles, and using padlocks.

11. **ALWAYS UNPLUG THE TOOL FROM THE ELECTRICAL RECEPTACLE** when making adjustments, changing parts or performing any maintenance.

SAFETY INSTRUCTIONS

12. KEEP PROTECTIVE GUARDS IN PLACE AND IN WORKING ORDER.

13. AVOID ACCIDENTAL STARTING. Make sure that the power switch is in the “OFF” position before plugging in the power cord to the electrical receptacle.

14. REMOVE ALL MAINTENANCE TOOLS from the immediate area prior to turning “ON” the machine.

15. USE ONLY RECOMMENDED ACCESSORIES. Use of incorrect or improper accessories could cause serious injury to the operator and cause damage to the tool. If in doubt, check the instruction manual that comes with that particular accessory.

16. NEVER LEAVE A RUNNING TOOL UNATTENDED. Turn the power switch to the “OFF” position. **DO NOT** leave the tool until it has come to a complete stop.

17. DO NOT STAND ON A TOOL. Serious injury could result if the tool tips over, or you accidentally contact the tool.

18. DO NOT store anything above or near the tool where anyone might try to stand on the tool to reach it.

19. MAINTAIN YOUR BALANCE. DO NOT extend yourself over the tool. Wear oil resistant rubber soled shoes. Keep floor clear of debris, grease, and wax.

20. MAINTAIN TOOLS WITH CARE. Always keep tools clean and in good working order. Keep all blades and tool bits sharp, dress grinding wheels and change other abrasive accessories when worn.

21. EACH AND EVERY TIME, CHECK FOR DAMAGED PARTS PRIOR TO USING THE TOOL. Carefully check all guards to see that they operate properly, are not damaged, and perform their intended functions. Check for alignment, binding or breaking of moving parts. A guard or other part that is damaged should be immediately repaired or replaced.

22. DO NOT OPERATE TOOL WHILE TIRED, OR UNDER THE INFLUENCE OF DRUGS, MEDICATION OR ALCOHOL.

23. SECURE ALL WORK. Use clamps or jigs to secure the work piece. This is safer than attempting to hold the work piece with your hands.

24. STAY ALERT, WATCH WHAT YOU ARE DOING, AND USE COMMON SENSE WHEN OPERATING A POWER TOOL.

A moment of inattention while operating power tools may result in serious personal injury.

25. ALWAYS WEAR A DUST MASK TO PREVENT INHALING DANGEROUS DUST OR AIRBORNE PARTICLES, including wood dust, crystalline silica dust and asbestos dust. Direct particles away from face and body. Always operate tool in well ventilated area and provide for proper dust removal. Use dust collection system wherever possible. Exposure to the dust may cause serious and permanent respiratory or other injury, including silicosis (a serious lung disease), cancer, and death. Avoid breathing the dust, and avoid prolonged contact with dust. Allowing dust to get into your mouth or eyes, or lay on your skin may promote absorption of harmful material. Always use properly fitting NIOSH/OSHA approved respiratory protection appropriate for the dust exposure, and wash exposed areas with soap and water.

26. USE A PROPER EXTENSION CORD IN GOOD CONDITION. When using an extension cord, be sure to use one heavy enough to carry the current your product will draw. The table on the following page shows the correct size to use depending on cord length and nameplate amperage rating. If in doubt, use the next heavier gauge. The smaller the gauge number, the larger diameter of the extension cord. If in doubt of the proper size of an extension cord, use a shorter and thicker cord. An undersized cord will cause a drop in line voltage resulting in a loss of power and overheating.
USE ONLY A 3-WIRE EXTENSION CORD THAT HAS A 3-PRONG GROUNDING PLUG AND A 3-POLE RECEPTACLE THAT ACCEPTS THE TOOL’S PLUG.

27. ADDITIONAL INFORMATION regarding the safe and proper operation of this product is available from:

- Power Tool Institute
1300 Summer Avenue
Cleveland, OH 44115-2851
www.powertoolinstitute.org
- National Safety Council
1121 Spring Lake Drive
Itasca, IL 60143-3201
www.nsc.org
- American National Standards Institute
25 West 43rd Street, 4th Floor
New York, NY 10036
www.ansi.org
- ANSI 01.1 Safety Requirements for Woodworking Machines and the U.S. Department of Labor regulations
www.osha.gov

28. SAVE THESE INSTRUCTIONS. Refer to them frequently and use them to instruct others.

SAFETY INSTRUCTIONS

ELECTRICAL SAFETY

⚠ WARNING: THIS TOOL MUST BE GROUNDED WHILE IN USE TO PROTECT THE OPERATOR FROM ELECTRIC SHOCK.

IN THE EVENT OF A MALFUNCTION OR BREAKDOWN, grounding provides the path of least resistance for electric current and reduces the risk of electric shock. This tool is equipped with an electric cord that has an equipment grounding conductor and requires a grounding plug (not included). The plug **MUST** be plugged into a matching electrical receptacle that is properly installed and grounded in accordance with **ALL** local codes and ordinances.

DO NOT MODIFY ANY PLUG. If it will not fit the electrical receptacle, have the proper electrical receptacle installed by a qualified electrician.

IMPROPER ELECTRICAL CONNECTION of the equipment grounding conductor can result in risk of electric shock. The conductor with the green insulation (with or without yellow stripes) is the equipment grounding conductor. **DO NOT** connect the equipment grounding conductor to a live terminal if repair or replacement of the electric cord or plug is necessary.

CHECK with a qualified electrician or service personnel if you do not completely understand the grounding instructions, or if you are not sure the tool is properly grounded when installing or replacing a plug.

USE ONLY A 3-WIRE EXTENSION CORD THAT HAS THE PROPER TYPE OF A 3-PRONG GROUNDING PLUG THAT MATCHES THE MACHINE'S 3-PRONG PLUG AND ALSO THE 3-POLE RECEPTACLE THAT ACCEPTS THE TOOL'S PLUG. *

REPLACE A DAMAGED OR WORN CORD IMMEDIATELY.

This tool is intended for use on a circuit that has an electrical receptacle as shown in **FIGURE A**. It shows a 3-wire electrical plug and electrical receptacle that has a grounding conductor. If a properly grounded electrical receptacle is not available, an adapter as shown in **FIGURE B** can be used to temporarily connect this plug to a 2-contact ungrounded receptacle. The adapter has a rigid lug extending from it that **MUST** be connected to a permanent earth ground, such as a properly grounded receptacle box. **THIS ADAPTER IS PROHIBITED IN CANADA.**

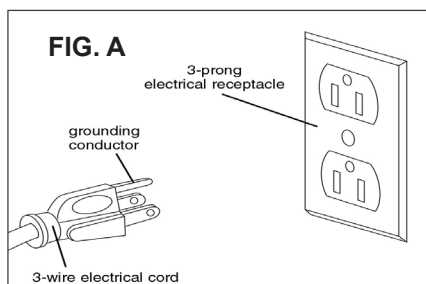

EXTENSION CORDS

⚠ WARNING: THE USE OF AN EXTENSION CORD WITH THIS MACHINE IS NOT RECOMMENDED. For best power and safety, plug the machine directly into a dedicated, grounded electrical outlet that is within the supplied cord length of the machine.

If an extension cord needs to be used, it should only be for a limited operation of the machine. The extension cord should be as short as possible in length, and have a minimum gauge size of 14AWG.

⚠ WARNING: Check extension cords before each use. If damaged replace immediately. Never use a tool with a damaged cord, since touching the damaged area could cause electrical shock, resulting in serious injury.

Use a proper extension cord. Only use cords listed by Underwriters Laboratories (UL). Other extension cords can cause a drop in line voltage, resulting in a loss of power and overheating of tool. When operating a power tool outdoors, use an outdoor extension cord marked "W-A" or "W". These cords are rated for outdoor use and reduce the risk of electric shock.

MINIMUM RECOMMENDED GAUGE FOR EXTENSION CORDS (AWG)

120 VOLT OPERATION ONLY				
	25' LONG	50' LONG	100' LONG	150' LONG
0 to 6 Amps	18 AWG	16 AWG	16 AWG	14 AWG
6 to 10 Amps	18 AWG	16 AWG	14 AWG	12 AWG
10 to 12 Amps	16 AWG	16 AWG	14 AWG	12 AWG

⚠ WARNING: Keep the extension cord clear of the working area. Position the cord so that it will not get caught on lumber, tools or other obstructions while you are working with your power tool.

* Canadian electrical codes require extension cords to be certified SJT type or better.

** The use of an adapter in Canada is not acceptable.

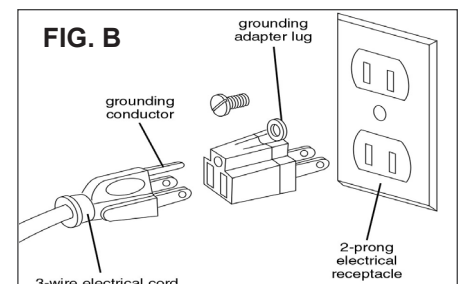

SAFETY INSTRUCTIONS

SPECIFIC SAFETY INSTRUCTIONS FOR BENCHTOP MORTISING MACHINES

This machine is intended for the drilling of square mortise holes in hard or softwoods. Any other use not as specified, including modification of the machine or use of parts not tested and approved by the equipment manufacturer, can cause unforeseen damage to the machine or operator, and invalidate the warranty.

ATTENTION: Use of this machine still presents risks that cannot be eliminated by the manufacturer. Therefore, the user must be aware that wood working machines are dangerous if not used with care and all safety precautions are adhered to.

1. Read and understand the entire owners manual before attempting assembly or operation.
2. Read and understand the warnings posted on the machine and in this manual. Failure to comply with all of these warnings may cause serious injury.
3. This mortiser is designed and intended for use by properly trained and experienced personnel only. If you are not familiar with the proper and safe operation of a mortiser, do not use until proper training has been obtained.
4. Do not use this mortiser for other than its intended use.
5. Always wear approved, safety protective eye wear and hearing protection when operating this machine.
6. Always wear a dust mask and use adequate dust collection and proper ventilation.
7. Before operating this mortiser, remove tie, rings, watches and other jewelry, and roll sleeves up past the elbows. Remove all loose clothing and confine long hair. Non-slip footwear or anti-skid floor strips are recommended. Do not wear gloves.
8. Do not operate this machine while tired or under the influence of drugs, alcohol or any medication.
9. Do not attempt to operate this machine until it is completely assembled.
10. Do not turn ON this machine if any pieces are damaged or missing.
11. Always make sure the power switch is in the OFF position prior to plugging in the machine.
12. Always make sure the power switch is in the OFF position and the machine is unplugged when doing any cleaning, assembly, setup operation, or when not in use.
13. This machine must be properly grounded.
14. Remove adjusting keys and wrenches before operating the mortiser. Form a habit of checking to see that keys, adjusting wrenches and any other tools are removed from the machine before turning it on.
15. Make sure the mortiser is firmly secured to the stand or bench before use.
16. Make sure all safety guards, clamps, hardware, etc. are securely tightened before operating the machine.
17. Sharpen or replace dull or chipped chisels or bits immediately, as injury to the user, or the machine, may result.
18. Check for damaged parts. Before further use of the machine, any part that is damaged should be carefully checked to determine that it will operate properly and perform its intended function. Check for alignment of moving parts, binding of moving parts, breakage of parts, mounting and any other conditions that may affect its operation. Any part that is damaged or worn should be properly repaired or replaced.
19. The use of any accessories or attachments not recommended may cause injury to you and damage your machine.
20. Use extra supports (roller stands, saw horses, tables etc.) for any work pieces large enough to tip when not held down to the table top surface.
21. Provide for adequate space surrounding work area and non-glare, overhead lighting.
22. Keep the floor around the machine clean and free of scrap material, oil and grease.
23. Keep visitors a safe distance from the work area. Keep children away.

This owner's manual is not a teaching aid and is intended to show assembly, adjustments, and general use.

CALIFORNIA PROPOSITION 65 WARNING: Some dust created by power sanding, sawing, grinding, drilling, and other construction activities contains chemicals known to the State of California to cause cancer and birth defects or other reproductive harm. Your risk from exposure to these chemicals varies, depending on how often you do this type of work. To reduce your exposure, work in a well-ventilated area and with approved safety equipment, such as dust masks that are specially designed to filter out microscopic particles.

For more detailed information about California Proposition 65 log onto rikontools.com.

GETTING TO KNOW YOUR MACHINE

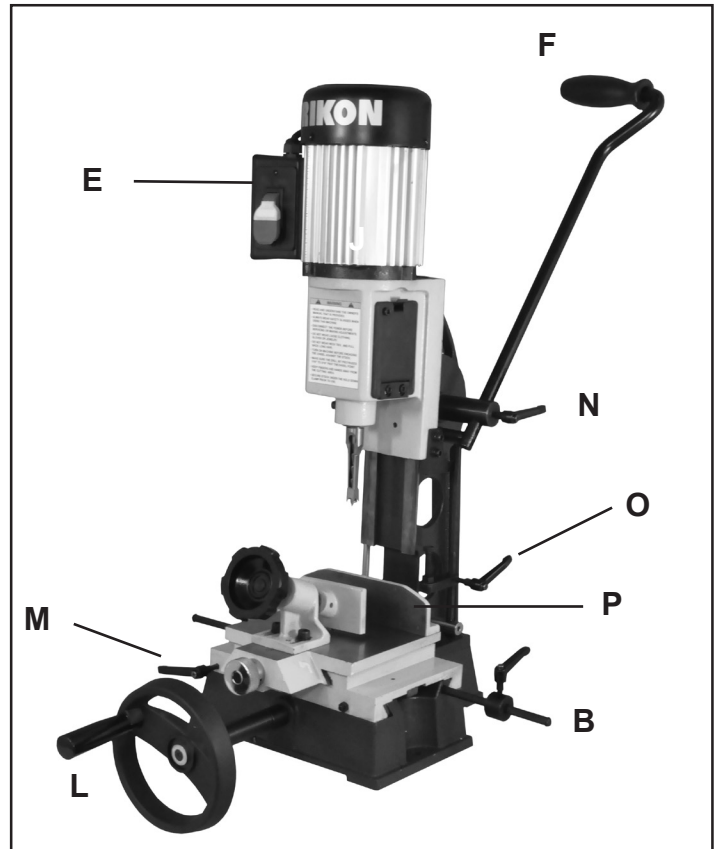
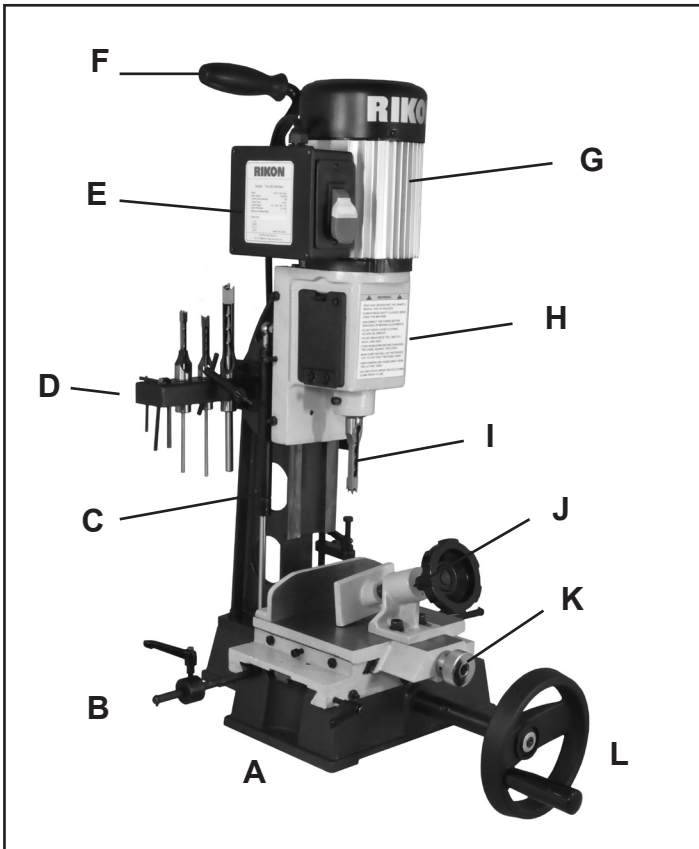

- A Base
- B Stop Rod & Locking Handle
- C Gas Return Strut
- D Tool Holder
- E On/Off Switch Electrical Box
- F Feed Handle
- G Motor
- H Chuck Housing & Access Covers

- I Chisel and Drill Bit
- J Hold Down Clamp
- K Table Control Knob - Forward-Back
- L Table Hand Wheel - Side-to-Side
- M Sliding Plate Locking Handle
- N Handle Locking Handle
- O Depth Stop Lock Lever
- P Fence

CONTENTS OF PACKAGE

Model 34-260 Benchtop Mortising Machine is shipped complete in one box.

Unpacking and Clean-up

1. Carefully remove all contents from the shipping carton. Compare the contents with the list of contents to make sure that all of the items are accounted for, before discarding any packing material. Place parts on a protected surface for easy identification and assembly. If any parts are missing or broken, please call RIKON Customer Service (877-884-5167) as soon as possible for replacements. DO NOT turn your machine ON if any of these items are missing. You may cause injury to yourself or damage to the machine.
2. Report any shipping damage to your local distributor. Take photographs for any possible insurance claims.
3. Clean all rust protected surfaces with ordinary house hold type grease or spot remover. Do not use; gasoline, paint thinner, mineral spirits, etc. These may damage painted surfaces.
4. Apply a coat of paste wax to the table to prevent rust. Wipe all parts thoroughly with a clean dry cloth.
5. Set packing material and shipping carton aside. Do not discard until the machine has been set up and is running properly.

CONTENTS OF PACKAGE

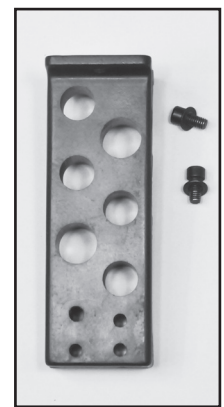
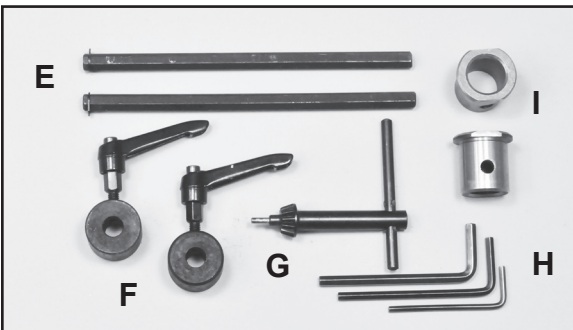
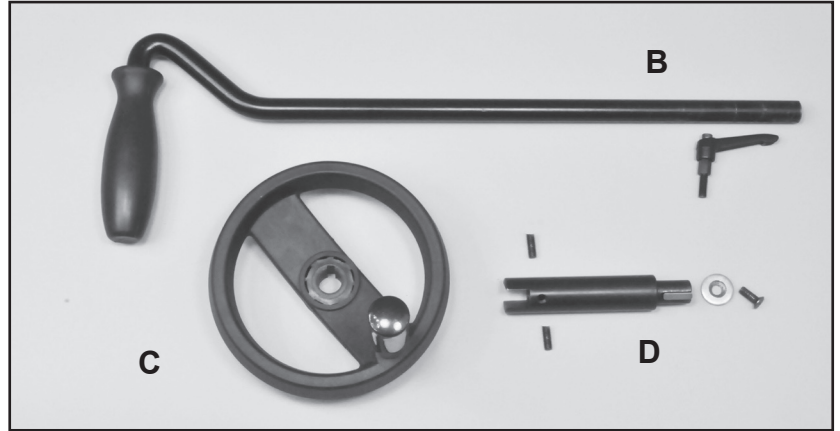
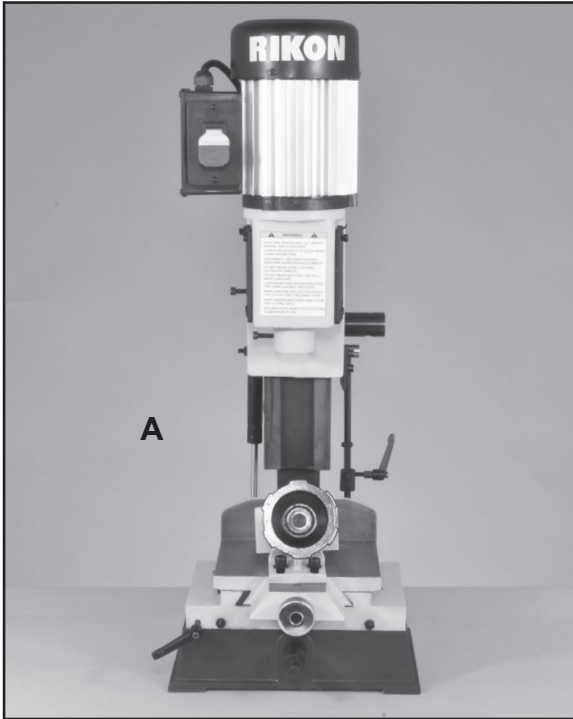

LIST OF LOOSE PARTS

- A. Bench Mortiser
- B. Handle & Locking Handle
- C. Hand Wheel
- D. Hand Wheel Shaft Extension & Screws
- E. Stop Rods
- F. Stop Rod Stop Collars & Handles
- G. Chuck Key
- H. Hex Wrenches - 3, 4, 5 & 6mm
- I. Bushings - 5/8" & 3/4"
- J. Chisels & Bits - 1/4", 5/16", 3/8" & 1/2"
- K. Tool Holder, 2 Screws & 2 Washers

ASSEMBLY



WARNING

THE MACHINE MUST NOT BE PLUGGED IN AND THE POWER SWITCH MUST BE IN THE 'OFF' POSITION UNTIL ASSEMBLY IS COMPLETE.

Tools Required for Assembly

#2 Phillips Screwdriver



ASSEMBLY

NOTE: Before assembly begins, make sure that the Mortiser is positioned on a sturdy work surface, and secured down to prevent any tipping.

Release the Mortising Head Assembly.

The Mortiser's head assembly is secured in the 'down' position for transporting, and must be freed for operation.

1. Loosen the locking hex head Screw (Part #64) that is located on the left side of the mortising head, next to the Gas Spring (#57). FIG. 1.

The Mortiser's head assembly should automatically rise once the locking screw is loosened.

- ## Install the Feed Handle (#1) into the Handle Shaft (#5), and secure it in place with the Locking Handle Screw (#4). FIG. 2.

The handle's lower end has a milled slot on the outside surface. The locking handle's screw should be positioned in this slot when secured.

- ## Install the Front Hand Wheel, which moves the sliding table left or right.

1. Attach the Handle Shaft (#84) onto the Gear Shaft (#83) which extends out from the front of the machine's Base (#25). Secure the shafts together with the two hex Set Screws (#86) that have been pre-installed on the Handle Shaft. FIG. 3.

2. Remove the Phillips Screw and Washer (#88 & 87) that are on the end of the handle shaft.

3. Slide the Hand Wheel (#85) onto the handle shaft. The locating key in the handle shaft must be positioned in the keyway slot in the hand wheel's center hole. FIG. 4.

4. Secure the hand wheel in position with the washer and screw that were removed in Step 1.

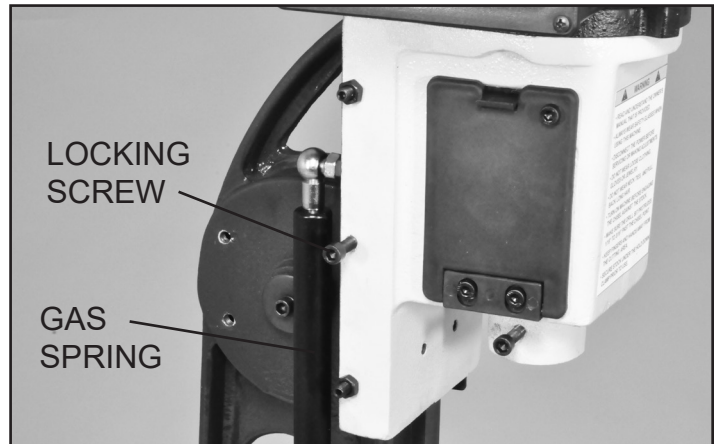

FIG. 1

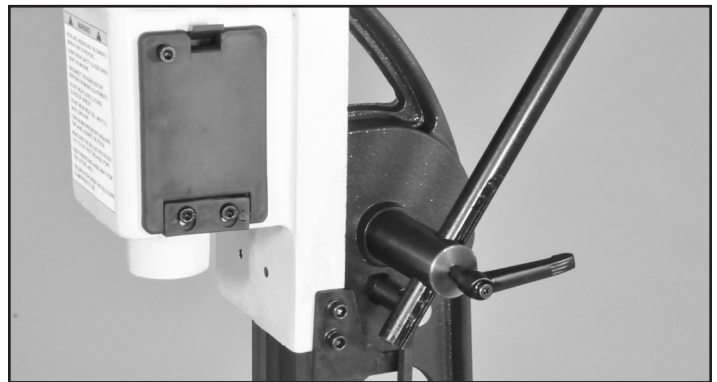

FIG. 2



FIG. 3

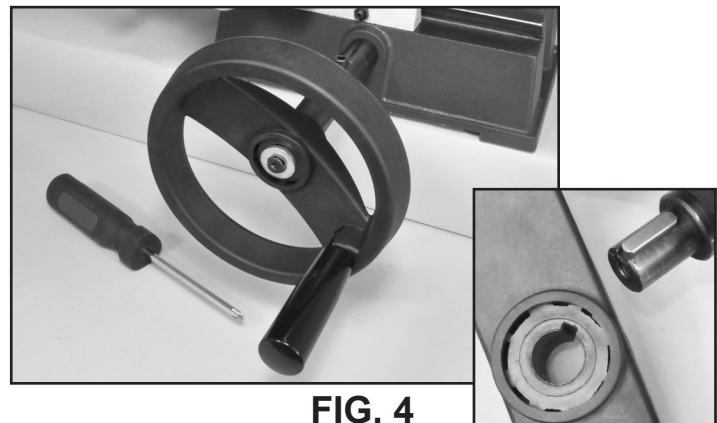

FIG. 4

ASSEMBLY

Install the Stop Rods.

Two stop rods and adjustable stop collars are supplied for installation on the left and right of the machine base. They can be set to restrict the left or right movement of the lower sliding table, so boring of long mortise holes will be accurate and consistent if multiple work pieces are drilled.

1. Slide an adjustable Stop Collar Assembly (#74, 75) onto each of the Stop Rods (#76), and lightly tighten them in place so that they do not move. FIG. 5.

2. Loosen the two Set Screws (#56) that are located on the machine base's dovetail way, just above the holes bored to take the stop rods. FIG. 6.

3. Insert the stop rods into the base holes and secure them in place by tightening the set screws that were loosened in step 2. FIG. 6.

NOTE: The stop collars can be moved along the stop rods and also rotated so that the adjustable locking Handles (#74) do not interfere with the sliding table.

Install the Tool Holder (#16) onto the upper left side of the column using two hex Screws with Washers (#18). FIG. 7.

Installing the Mortising Chisel and Drill Bit

The 34-260 Mortiser uses 1", 3/4" or 5/8" diameter shank chisels with a 3" cutting depth.

1. Open the chuck access Cover (#14)(A) and loosen the side bushing set Screw (#86)(B). FIG. 8.

2. The Mortiser's head comes bored with a 1" diameter hole for chisels with 1" shanks. For other diameter chisels shanks, the use of the 3/4" or 5/8" bushing is required. Install the bushing (FIG. 8, C), if needed, and slightly tighten the bushing set screw to keep the bushing in place.

Continued on page 11

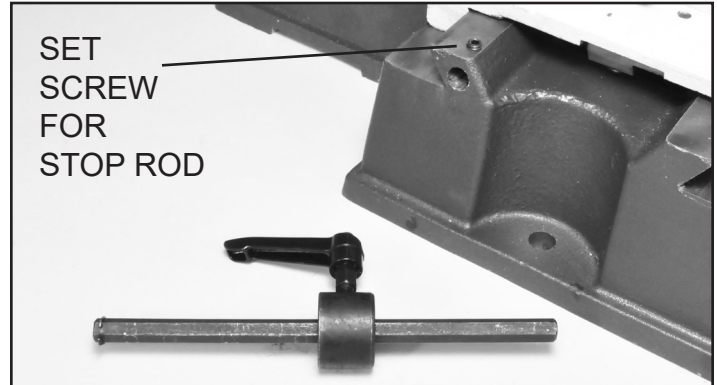

FIG. 5

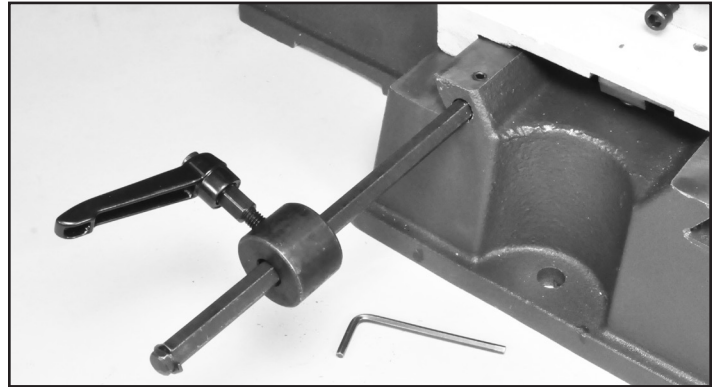

FIG. 6

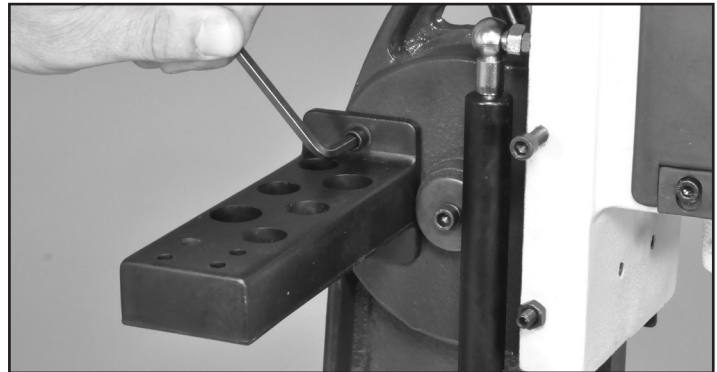

FIG. 7

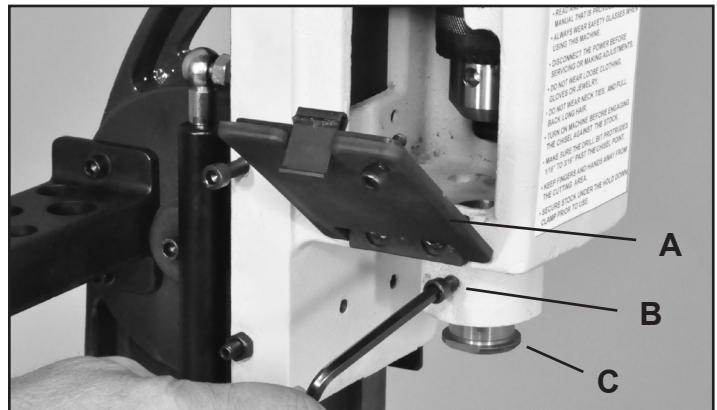

FIG. 8

ASSEMBLY

3. Open the chuck jaws to allow the drill bit to be inserted into the chuck, and then insert the chisel into the mortiser's head, or head with a bushing installed.

4. Tighten the bushing set screw to secure the chisel in place. FIG. 9, A.

5. Using the chuck key, tighten the drill bit in place making sure that 1/16" to 3/16" of the drill bit point is lower than the chisel point. This distance will depend on wood hardness and mortising depth requirements. FIG. 10, B.

6. The chisel must be set square to the fence. This can be done by two means:

A - Remove the Clamping Assembly (#37+) from the table (#42) to gain access to the chisel. Place a square against the fence and side of the chisel. FIG. 11. If an adjustment is needed, loosen the bushing set screw and rotate the chisel until it is square with the fence. Then tighten the bushing set screw. Re-install the clamping assembly once the chisel is set.

B - The back side of the square chisel can also be set parallel to the Fence (#45), by advancing the fence until it touches the chisel.

- The chisel can be adjusted/rotated in the bushing (as in A above).
- Or the Fence can be adjusted to the chisel by loosening the fence's Screws (#44) and shifting the fence until it touches the back surface of the chisel. Then tighten the fence screws to secure the fence in position.

WARNING THE MACHINE MUST NOT BE PLUGGED IN AND THE POWER SWITCH MUST BE IN THE OFF POSITION UNTIL ALL ADJUSTMENTS ARE COMPLETE.

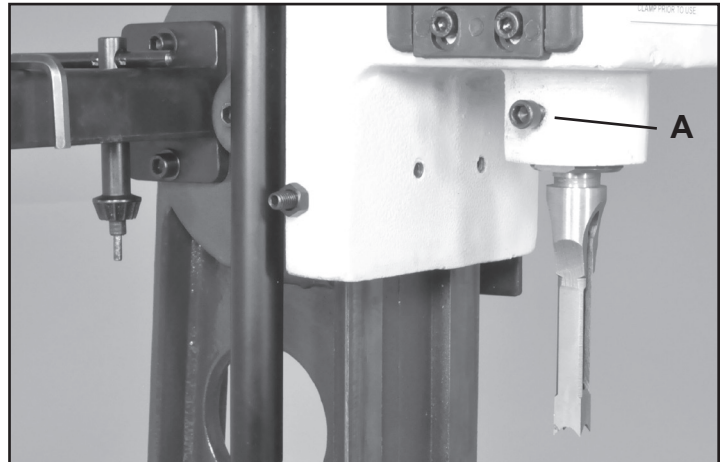

FIG. 9

WARNING WEAR PROTECTIVE GLOVES WHILE HANDLING CHISELS.

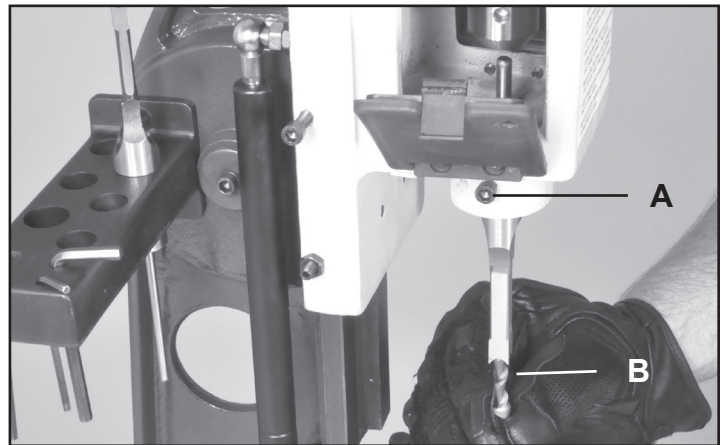

FIG. 10

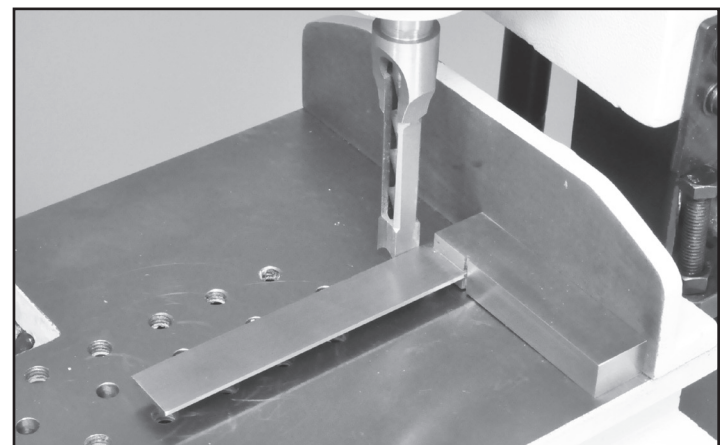
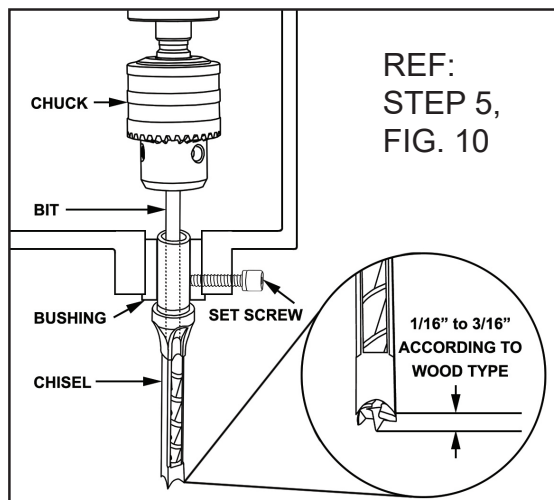

FIG. 11

ADJUSTMENTS

Adjusting the Work Table

The top Table (#42) that holds your work piece, adjusts forward and backwards on dovetail ways, FIG. 12, A. The table movement is controlled by the small knurled Knob (#38) (B).

1. To tighten or loosen the movement of the table, pressure on the dovetails can be adjusted with the 2 Screws and Nuts (# 54, 53). FIG. 12, C. These put pressure on the Drift Plate (#55) which rests against the table's dovetails.

2. To secure the table in one spot so that it will not move, the hex head Screw (#64) (D) can be fastened down. This is recommended for repetitive drilling of mortises on multiple work pieces.

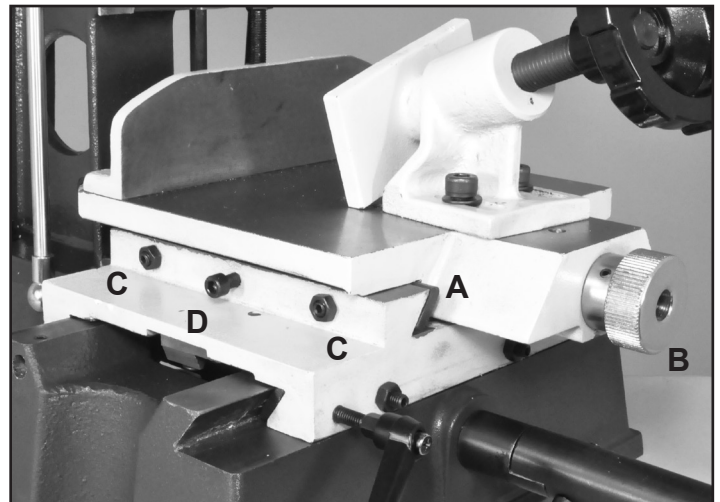

FIG. 12

Adjusting the Lower Sliding Plate

The lower supporting Sliding Plate (#52) adjusts the top table left and right on a separate set of dovetail ways. FIG. 13, A. The front Hand Wheel (#33) (B) controls the side-to-side table movement.

1. To tighten or loosen the movement of the sliding plate, pressure on the dovetails can be adjusted with the 3 Screws and Nuts (# 47, 48) that are located in the front of the sliding plate. FIG. 13, C. These put pressure on the Drift Plate (#24) which rests against the plate's dovetails.

2. To secure the sliding plate in one spot so that it will not move, the Handle Screw (#49) (D) can be fastened down. This is recommended for repetitive drilling in a single location on multiple work pieces.

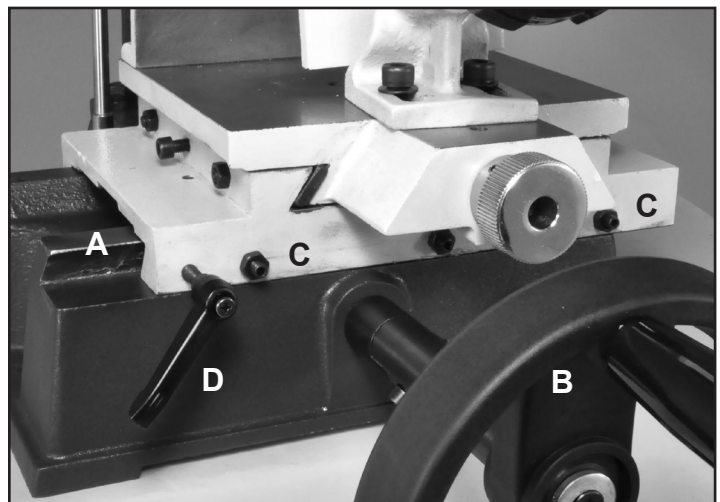

FIG. 13

Adjusting the Table Clamp

The Table Clamp Assembly (#37) can be adjusted to hold different sizes of work against the fence for the accurate drilling of mortises.

The Table has rows of multiple pre-drilled holes that the Clamp Base Casting and Pin (#37, 18) fit into to adjust for clamping different material widths. FIG. 14.

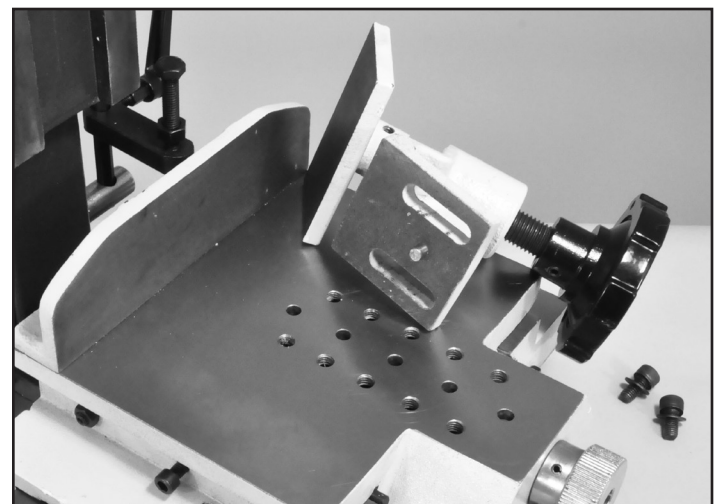

FIG. 14

Continued on page 13

ADJUSTMENTS

Continued from page 12

The front Clamp Plate (#43) will rotate slightly to give pressure on irregular shaped pieces, and the Clamping Base (#37) can be angled to conform to tapered work pieces. The two Bolts (#32) can be loosened and tightened to secure the fence in position for maximum holding power. FIG. 15.

⚠ WARNING THE MACHINE MUST NOT BE PLUGGED IN AND THE POWER SWITCH MUST BE IN THE OFF POSITION UNTIL ALL ADJUSTMENTS ARE COMPLETE.

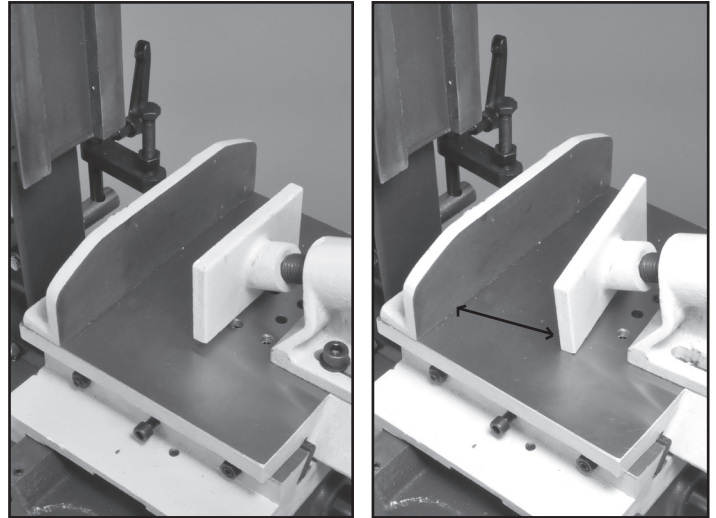

FIG. 15

Adjusting the Depth Stop

Drilling depths of the mortiser can be set with the adjustments on the right side of the column. To set a specific depth for mortising with the chisel and bit;

1. Mark your mortise depth on the side of your work piece, or scrap material, for reference. Position the chisel and bit that you will be using against this mark. FIG. 16. To keep the mortising head in this location, the locking head Screw (#64 - see page 9) can be tightened.

NOTE: The depth of the mortise should be set to the chisel point, not to the tip of the drill bit. The extra depth cut by the drill bit will allow room for any excess glue.

2. Position the depth stop Plate (#81, FIG, 17, A) along the Guide Column Rod (#10) until the hex head Bolt (#79) hits the Depth Stop Plate (#12), B, that is mounted on the mortiser's head.

3. Lock the stop plate in position with the Handle Screw (#8) C. The depth stop is set for your drilling. If further fine tuning is needed, the Bolt (#79) can be adjusted and locked in position with the hex Nut (#80).

4. Unlock the head Screw (tightened in step 1) so that the mortising head is released.

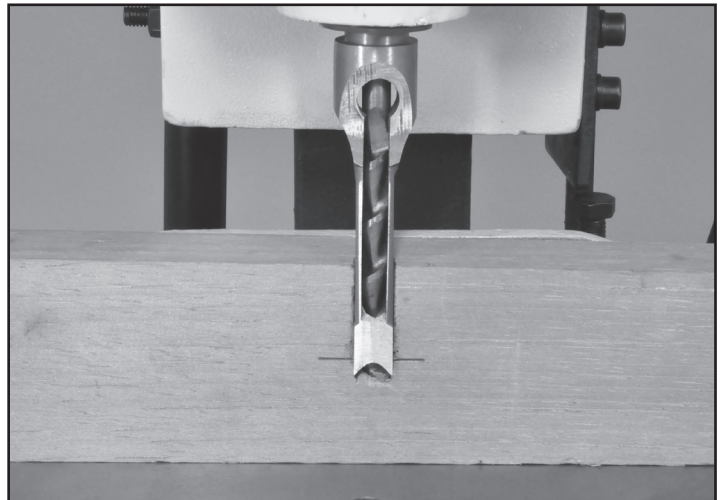

FIG. 16

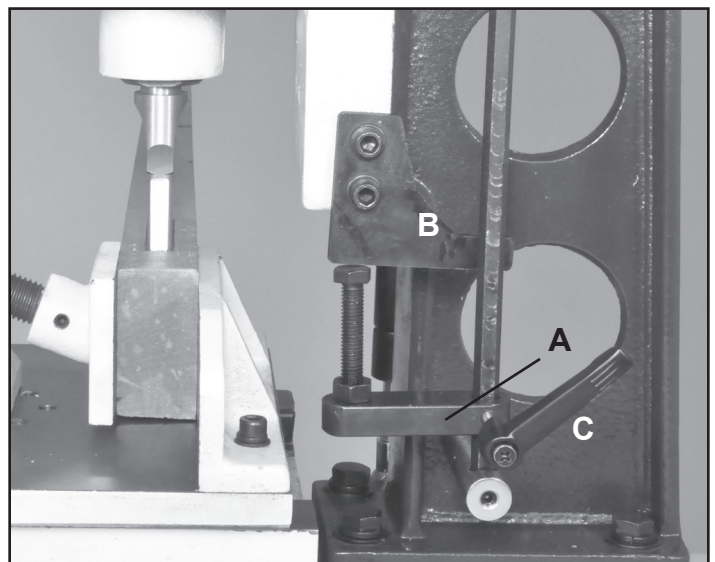

FIG. 17

OPERATION



WARNING

Before turning on the machine, review the safety precautions listed on pages 3 to 6. Make sure that you fully understand the features, adjustments and capabilities of the machine that are outlined throughout this manual. Tips on usage can be found in books, magazines, researching the internet and other resources.

Once all of the machine adjustments have been set, and the chisel & bit size has been chosen and installed in the mortiser, prepare your work piece for cutting of the mortise(s).

1. Mark your mortise size and location on the surface of your work piece.
2. Set the chisel & bit to the desired mortise depth - see Depth Stop instructions on page 13.
3. Set the work table and fence location so the chisels & bit are positioned perfectly to bore the mortise(s) in the correct location on your work piece. See pages 12 and 13.
4. Position the table clamp so that it will securely

hold the work piece for drilling. See pages 12 & 13.

5. If needed for duplicate drilling in multiple pieces, adjust the stop collars to set the left and right movement of the sliding table. See page 10.
6. Plug in the machine to begin working.
7. Start the mortiser and feed the chisel into the work piece. Feed the chisel to a depth of 1/2" then retract it to allow the chips to clear. Make repeated small cuts, allowing the chisel to do the work while clearing the chips. Do not force the cut or the motor will slow down.
For long mortises, cut one end, then move the work piece and drill the other end. Finally, bore out the material between the two holes to complete the mortise.

MAINTENANCE



WARNING:

Turn the power switch "OFF" and disconnect the plug from the outlet prior to adjusting or maintaining the machine. DO NOT attempt to repair or maintain the electrical components of the motor. Contact a qualified service technician for this type of maintenance.

1. Before each use:
 - Check the power cord and plug for any wear or damage.
 - Check for any loose screws or hardware.
 - Check the area to make sure it is clear of any misplaced tools, lumber, cleaning supplies, etc. that could hamper the safe operation of the machine.
2. The chisel and bit should be kept sharp for best performance. Blunt edges will give inaccurate mortises and can lead to overheating and breakage to chisel or bit. If chisel and bit are badly worn and become difficult to sharpen, they should be replaced.
3. To avoid a build-up of wood dust, regularly clean all parts of the machine using a soft cloth, brush or compressed air. A general cleaning

should be done after every use to avoid future problems and ensure the machine is in ready condition for the next time it is used

WARNING: If blowing sawdust, wear proper eye protection to prevent debris from blowing into eyes.

4. Clean all parts of the mortiser on a regular basis. Treat the rods and moving parts with a dry lubricant spray. Do not use ordinary oil which will collect dust and hamper the operation of the machine.
5. Keep the machined surfaces free of resin and rust. Clean them regularly with a non-flammable solvent, then coat with a light film of dry lubricant spray, or wax, to enhance passage of work piece on/over the table(s).

TROUBLESHOOTING

PROBLEM	PROBABLE CAUSE	REMEDY
Motor will not start. Fuses or circuit breakers trip or blow.	<ol style="list-style-type: none"> 1. Machine is not plugged in. 2. Fuse or circuit breaker are open. 3. Power switch or cord is faulty. 4. Open circuit in the motor or loose connections. 	<ol style="list-style-type: none"> 1. Plug power cord in electrical outlet. 2. Replace fuse or circuit breaker. 3. Replace switch or cord. 4. Inspect all connections on motor and wires.
Motor overheats.	<ol style="list-style-type: none"> 1. Motor is overloaded. 2. Poor air circulation around motor. 3. Overuse, particularly if in a high temperature room. 	<ol style="list-style-type: none"> 1. Reduce load on the motor. 2. Remove any blockage or dust build-up around the motor. 3. Reduce motor run time.
Machine stalls or runs slow.	<ol style="list-style-type: none"> 1. Motor is overloaded. 2. Low voltage in electrical line. 3. Motor capacitor has failed. 4. Feed rate is too great. 	<ol style="list-style-type: none"> 1. Reduce load on the motor. 2. Correct low voltage conditions. 3. Replace motor capacitor. 4. Reduce rate and force when drilling.
Difficulty pulling handle down during boring.	<ol style="list-style-type: none"> 1. Chisel or drill bit is dull. 2. Drill bit does not extend out far enough from the chisel. 3. Chisel is too big for the job. 	<ol style="list-style-type: none"> 1. Sharpen or replace the chisel & bit. 2. Reposition the drill bit in the chisel. 3. Reduce the size of the chisel. Drill multiple smaller holes instead of one.
Chisel & Bit are noisy.	<ol style="list-style-type: none"> 1. Chisel or drill bit are bent. 2. Drill bit is not aligned with chisel. 3. Bushing is loose, or not aligned. 	<ol style="list-style-type: none"> 1. Replace with a new chisel & bit set. 2. Reinstall bit in the chuck and chisel. 3. Reinstall the bushing & chisel.
Work piece is smoking and burning during mortise drilling.	<ol style="list-style-type: none"> 1. Drill bit is dull. 2. Drilling feed rate is too great. 3. Wood chips are stuck in the chisel and are overheating the drill bit. 4. Wood is green or pressure treated. 	<ol style="list-style-type: none"> 1. Sharpen or replace the chisel & bit. 2. Reduce the feed rate and handle force. 3. Clear wood chips often from chisel. Extend drill bit further out from chisel. 4. Drill only dry, untreated wood.

WIRING DIAGRAM

⚠ WARNING: This machine must be grounded. Replacement of the power supply cable should only be done by a qualified electrician. See page 5 for additional electrical information.

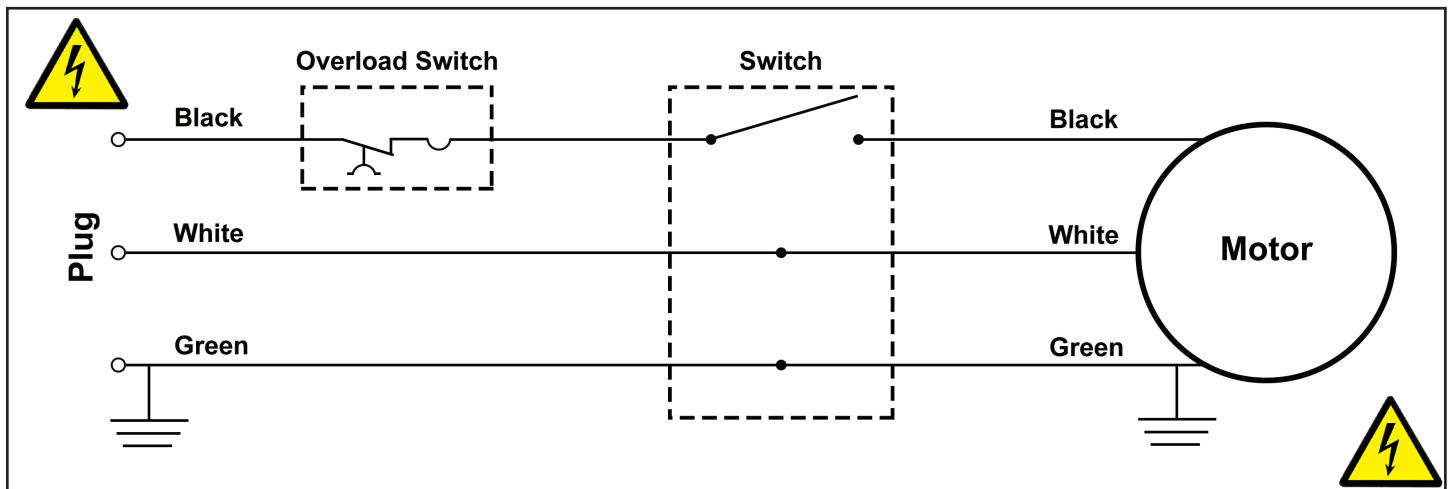

PARTS DIAGRAM

34-260 BENCHTOP MORTISING MACHINE

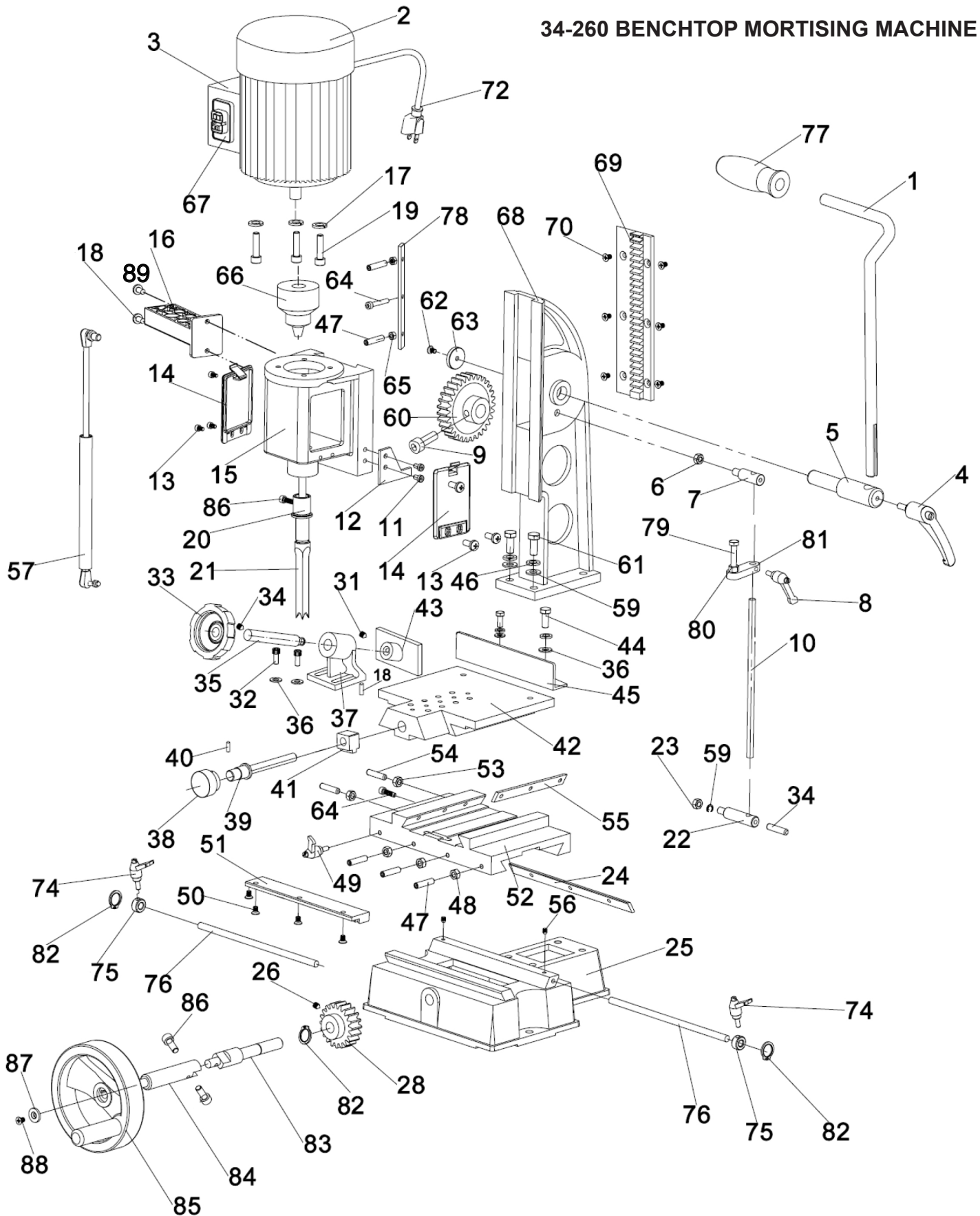

NOTE: Please reference the Manufacturer's Part Number when calling for Replacement Parts. For Parts under Warranty, the Serial Number of your machine is required.

PARTS LIST

KEY NO.	DESCRIPTION	QTY.	PART NO.	KEY NO.	DESCRIPTION	QTY.	PART NO.
1	Operating Lever Handle	1	P34-260-1	46	Spring Washer	2	P34-260-46
2	Motor	1	P34-260-2	47	Screw	3	P34-260-47
3	Switch Box	1	P34-260-3	48	Nut	3	P34-260-48
4	Handle Screw	1	P34-260-4	49	Handle Screw	2	P34-260-49
5	Handle Shaft	1	P34-260-5	50	Screw	4	P34-260-50
6	Nut	1	P34-260-6	51	Rack	1	P34-260-51
7	Screw	1	P34-260-7	52	Sliding Plate	1	P34-260-52
8	Handle Screw	1	P34-260-8	53	Nut	2	P34-260-53
9	Set Screw	1	P34-260-9	54	Screw	2	P34-260-54
10	Guide Column Rod	1	P34-260-10	55	Drift	1	P34-260-55
11	Screw	2	P34-260-11	56	Set Screw	2	P34-260-56
12	Depth Stop Plate	1	P34-260-12	57	Gas Spring	1	P34-260-57
13	Screw	4	P34-260-13	58	Screw	1	P34-260-58
14	Cover	2	P34-260-14	59	Washer	4	P34-260-59
15	Headbox Casting	1	P34-260-15	60	Gear	1	P34-260-60
16	Tool Holder	1	P34-260-16	61	Bolt	4	P34-260-61
17	Washer	3	P34-260-17	62	Screw	1	P34-260-62
18	Cap Screw	2	P34-260-18	63	Plate	1	P34-260-63
19	Bolt	3	P34-260-19	64	Screw	3	P34-260-64
20	Chisel Bushing 5/8"	1	P34-255-43	65	Nut	2	P34-260-65
	Chisel Bushing 3/4"	1	P34-255-43A	66	Chuck	1	P34-260-66
21	Chisel (see Accessories)	1	P34-260-21	67	ON/OFF Switch	1	P34-260-67
22	Screw	1	P34-260-22	68	Column	1	P34-260-68
23	Nut	1	P34-260-23	69	Rack	1	P34-260-69
24	Drift	1	P34-260-24	70	Screw	6	P34-260-70
25	Base	1	P34-260-25	72	Power Cord	1	P34-260-72
26	Screw	2	P34-260-26	74	Handle Screw	2	P34-260-74
28	Gear	1	P34-260-28	75	Setting Collar	2	P34-260-75
31	Screw	1	P34-260-31	76	Stop Rod	2	P34-260-76
32	Bolt	2	P34-260-32	77	Handle Grip Sleeve	1	P34-260-77
33	Table Clamp	1	P34-260-33	78	Drift	1	P34-260-78
34	Screw	1	P34-260-34	79	Bolt	1	P34-260-79
35	Lead Screw	1	P34-260-35	80	Nut	1	P34-260-80
36	Washer	2	P34-260-36	81	Plate	1	P34-260-81
37	Clamp Casting	1	P34-260-37	82	C -Ring	2	P34-260-82
38	Table Control Knob	1	P34-260-38	83	Gear Shaft	1	P34-260-83
39	Lead Screw	1	P34-260-39	84	Handle Shaft	1	P34-260-84
40	Pin	1	P34-260-40		Handle Shaft Key	1	P34-260-84A
41	Lead Nut	1	P34-260-41	85	Hand Wheel	1	P34-260-85
42	Table	1	P34-260-42	86	Set Screws M6x6	2	P34-260-86
43	Clamp Plate	1	P34-260-43	87	Washer	1	P34-260-87
44	Screw	4	P34-260-44	88	Set Screw	1	P34-260-88
45	Fence	1	P34-260-45	89	Washer	2	P34-260-89

ACCESSORIES



MORTISING CHISELS AND BITS

Machined steel chisels have 5/8" shanks. Drill bits have brad points, single cutting edge and up-spiral flutes for rapid chip removal. Both chisel and bits require final sharpening before use.

29-914L 1/4" Mortising Chisel & Bit

29-915L 5/16" Mortising Chisel & Bit

29-913 3/8" Mortising Chisel & Bit

29-912 1/2" Mortising Chisel & Bit

NOTES

Use this section to record maintenance, service and any calls to Technical Support:

RIKON

POWER TOOLS®

5-Year Limited Warranty

RIKON Power Tools Inc. ("Seller") warrants to only the original retail consumer/purchaser of our products that each product be free from defects in materials and workmanship for a period of five (5) years from the date the product was purchased at retail. This warranty may not be transferred.

This warranty does not apply to defects due directly or indirectly to misuse, abuse, negligence, accidents, repairs, alterations, lack of maintenance or normal wear and tear. Under no circumstances will Seller be liable for incidental or consequential damages resulting from defective products. All other warranties, expressed or implied, whether of merchantability, fitness for purpose, or otherwise are expressly disclaimed by Seller. This five-year warranty does not cover products used for commercial, industrial or educational purposes. The warranty term for these claims will be limited to a two-year period.

This limited warranty does not apply to accessory items such as blades, drill bits, sanding discs, grinding wheels, belts, guide bearings and other related items.

Seller shall in no event be liable for death, injuries to persons or property, or for incidental, contingent, special, or consequential damages arising from the use of our products.

To take advantage of this warranty, proof of purchase documentation must be provided which has the date of purchase and an explanation of the complaint.

The Seller reserves the right to effect at any time, without prior notice, those alterations to parts, fittings, and accessory equipment which they may deem necessary for any reason whatsoever.

To register your machine online, visit RIKON at www.rikontools.com/warranty

**To take advantage of this warranty, or if you have any questions,
please contact us at 877-884-5167 or email warranty@rikontools.com**



For more information:
16 Progress Road
Billerica, MA 01821

877-884-5167 / 978-528-5380
techsupport@rikontools.com

