

## 10 Ton Kinetic Rapid Log Splitter



## Operator's Manual

Record the serial number and date of purchase in your manual for future reference.  
The serial number can be found on the specification label on the rear of your machine.

Serial Number: \_\_\_\_\_ Date of purchase: \_\_\_\_\_

For technical support or parts questions, email [techsupport@rikontools.com](mailto:techsupport@rikontools.com) or call toll free at (877)884-5167

## TABLE OF CONTENTS

Specifications.....	2
Safety Instructions .....	3 - 6
Getting To Know Your Log Splitter .....	7
Contents of Package .....	8
Assembly .....	8
Operation .....	9
Maintenance .....	10
Troubleshooting .....	11
Electricals & Wiring Diagram .....	5 & 11
Parts List & Parts Diagram .....	12 & 13
Notes .....	14
Warranty .....	15

## SPECIFICATIONS

Motor .....	2 HP
Motor Speed (no load).....	1,720 RPM
Volts .....	120 V
Amps, Hertz, Phase .....	9 A, 60 Hz, 1Ph
Cutting Capacity Length.....	21"
Cutting Capacity Diameter.....	12"
Splitting Wedge Height.....	6" (152.4mm)
Ram Cycle Time (Return).....	1 Second
Number of Flywheels.....	2
Flywheel Weight (ea.).....	20.5lbs (9.30 kg)
Flywheel Rotational Speed.....	450 RPM
Height .....	30-11/16" (779 mm)
Width .....	14-3/16" (330 mm)
Depth .....	27" (686 mm)
Net Weight .....	141lbs (64 kg)

**NOTE:** The specifications, photographs, drawings and information in this manual represent the current model when the manual was prepared. Changes and improvements may be made at any time, with no obligation on the part of Rikon Power Tools, Inc. to modify previously delivered units. Reasonable care has been taken to ensure that the information in this manual is correct, to provide you with the guidelines for the proper safety, assembly and operation of this machine.

# SAFETY INSTRUCTIONS

**IMPORTANT!** Safety is the single most important consideration in the operation of this equipment. **The following instructions must be followed at all times.** Failure to follow all instructions listed below may result in electric shock, fire, and/or serious personal injury.

There are certain applications for which this tool was designed. We strongly recommend that this tool not be modified and/or used for any other application other than that for which it was designed. If you have any questions about its application, do not use the tool until you have contacted us and we have advised you.

## SAFETY SYMBOLS



**SAFETY ALERT SYMBOL:** Indicates DANGER, WARNING, or CAUTION. This symbol may be used in conjunction with other symbols or pictographs.



Indicates an imminently hazardous situation, which, if not avoided, could result in death or serious injury.



Indicates a potentially hazardous situation, which, if not avoided, could result in death or serious injury.



Indicates a potentially hazardous situation, which, if not avoided, could result in minor or moderate injury.

**NOTICE:** Shown without Safety Alert Symbol indicates a situation that may result in property damage.

## GENERAL SAFETY

**KNOW YOUR POWER TOOL.** Read the owner's manual carefully. Learn the tool's applications, work capabilities, and its specific potential hazards.

### BEFORE USING YOUR MACHINE

To avoid serious injury and damage to the tool, read and follow all of the Safety and Operating Instructions before operating the machine.

1. Some dust created by using power tools contains chemicals known to the State of California to cause cancer, birth defects, or other reproductive harm. Some examples of these chemicals are:
  - Lead from lead-based paints.
  - Crystalline silica from bricks, cement, and other masonry products.
  - Arsenic and chromium from chemically treated lumber.Your risk from these exposures varies, depending on how often you do this type of work. To reduce your exposure to these chemicals: work in a well ventilated area and work with approved safety equipment, such as those dust masks that are specially designed to filter out microscopic particles.
2. **READ** the entire Owner's Manual. **LEARN** how to use the tool for its intended applications.
3. **GROUND ALL TOOLS.** If the tool is supplied with a 3 prong plug, it must be plugged into a 3-contact electrical receptacle. The 3rd prong is used to ground the tool and provide protection against accidental electric shock. **DO NOT** remove the 3rd prong. See Grounding Instructions on the following pages.

4. **AVOID A DANGEROUS WORKING ENVIRONMENT. DO NOT** use electrical tools in a damp environment or expose them to rain.

5. **DO NOT** use electrical tools in the presence of flammable liquids or gasses.

6. **ALWAYS** keep the work area clean, well lit, and organized. **DO NOT** work in an environment with floor surfaces that are slippery from debris, grease, and wax.

7. **KEEP VISITORS AND CHILDREN AWAY. DO NOT** permit people to be in the immediate work area, especially when the electrical tool is operating.

8. **DO NOT FORCE THE TOOL** to perform an operation for which it was not designed. It will do a safer and higher quality job by only performing operations for which the tool was intended.

9. **WEAR PROPER CLOTHING. DO NOT** wear loose clothing, gloves, neckties, or jewelry. These items can get caught in the machine during operations and pull the operator into the moving parts. The user must wear a protective cover on their hair, if the hair is long, to prevent it from contacting any moving parts.

10. **CHILDPROOF THE WORKSHOP AREA** by removing switch keys, unplugging tools from the electrical receptacles, and using padlocks.

11. **ALWAYS UNPLUG THE TOOL FROM THE ELECTRICAL RECEPTACLE** when making adjustments, changing parts or performing any maintenance.

# SAFETY INSTRUCTIONS

12. **KEEP PROTECTIVE GUARDS IN PLACE AND IN WORKING ORDER.**
13. **AVOID ACCIDENTAL STARTING.** Make sure that the power switch is in the "OFF" position before plugging in the power cord to the electrical receptacle.
14. **REMOVE ALL MAINTENANCE TOOLS** from the immediate area prior to turning "ON" the machine.
15. **USE ONLY RECOMMENDED ACCESSORIES.** Use of incorrect or improper accessories could cause serious injury to the operator and cause damage to the tool. If in doubt, check the instruction manual that comes with that particular accessory.
16. **NEVER LEAVE A RUNNING TOOL UNATTENDED.** Turn the power switch to the "OFF" position. **DO NOT** leave the tool until it has come to a complete stop.
17. **DO NOT STAND ON A TOOL.** Serious injury could result if the tool tips over, or you accidentally contact the tool.
18. **DO NOT** store anything above or near the tool where anyone might try to stand on the tool to reach it.
19. **MAINTAIN YOUR BALANCE. DO NOT** extend yourself over the tool. Wear oil resistant rubber soled shoes. Keep floor clear of debris, grease, and wax.
20. **MAINTAIN TOOLS WITH CARE.** Always keep tools clean and in good working order. Keep all blades and tool bits sharp, dress grinding wheels and change other abrasive accessories when worn.
21. **EACH AND EVERY TIME, CHECK FOR DAMAGED PARTS PRIOR TO USING THE TOOL.** Carefully check all guards to see that they operate properly, are not damaged, and perform their intended functions. Check for alignment, binding or breaking of moving parts. A guard or other part that is damaged should be immediately repaired or replaced.
22. **DO NOT OPERATE TOOL WHILE TIRED, OR UNDER THE INFLUENCE OF DRUGS, MEDICATION OR ALCOHOL.**
23. **SECURE ALL WORK.** Use clamps or jigs to secure the work piece. This is safer than attempting to hold the work piece with your hands.
24. **STAY ALERT, WATCH WHAT YOU ARE DOING, AND USE COMMON SENSE WHEN OPERATING A POWER TOOL.**

A moment of inattention while operating power tools may result in serious personal injury.
25. **ALWAYS WEAR A DUST MASK TO PREVENT INHALING DANGEROUS DUST OR AIRBORNE PARTICLES,** including wood dust, crystalline silica dust and asbestos dust. Direct particles away from face and body. Always operate tool in well ventilated area and provide for proper dust removal. Use dust collection system wherever possible. Exposure to the dust may cause serious and permanent respiratory or other injury, including silicosis (a serious lung disease), cancer, and death. Avoid breathing the dust, and avoid prolonged contact with dust. Allowing dust to get into your mouth or eyes, or lay on your skin may promote absorption of harmful material. Always use properly fitting NIOSH/OSHA approved respiratory protection appropriate for the dust exposure, and wash exposed areas with soap and water.
26. **USE A PROPER EXTENSION CORD IN GOOD CONDITION.** When using an extension cord, be sure to use one heavy enough to carry the current your product will draw. The table on the following page shows the correct size to use depending on cord length and nameplate amperage rating. If in doubt, use the next heavier gauge. The smaller the gauge number, the larger diameter of the extension cord. If in doubt of the proper size of an extension cord, use a shorter and thicker cord. An undersized cord will cause a drop in line voltage resulting in a loss of power and overheating.

**USE ONLY A 3-WIRE EXTENSION CORD THAT HAS A 3-PRONG GROUNDING PLUG AND A 3-POLE RECEPTACLE THAT ACCEPTS THE TOOL'S PLUG.**
27. **ADDITIONAL INFORMATION** regarding the safe and proper operation of this product is available from:
  - Power Tool Institute  
1300 Summer Avenue  
Cleveland, OH 44115-2851  
[www.powertoolinstitute.org](http://www.powertoolinstitute.org)
  - National Safety Council  
1121 Spring Lake Drive  
Itasca, IL 60143-3201  
[www.nsc.org](http://www.nsc.org)
  - American National Standards Institute  
25 West 43rd Street, 4th Floor  
New York, NY 10036  
[www.ansi.org](http://www.ansi.org)
  - ANSI O1.1 Safety Requirements for Woodworking Machines and the U.S. Department of Labor regulations  
[www.osha.gov](http://www.osha.gov)
28. **SAVE THESE INSTRUCTIONS.** Refer to them frequently and use them to instruct others.



# SAFETY INSTRUCTIONS

## ELECTRICAL SAFETY

**⚠️ WARNING:** THIS TOOL IS PRE-WIRED FOR 120V CIRCUITS, AND MUST BE GROUNDED WHILE IN USE TO PROTECT THE OPERATOR FROM ELECTRIC SHOCK.

**IN THE EVENT OF A MALFUNCTION OR BREAKDOWN,** grounding provides the path of least resistance for electric current and reduces the risk of electric shock. This tool is equipped with an electric cord that has an equipment grounding conductor and requires a grounding plug (not included). The plug **MUST** be plugged into a matching electrical receptacle that is properly installed and grounded in accordance with **ALL** local codes and ordinances.

**DO NOT MODIFY ANY PLUG.** If it will not fit the electrical receptacle, have the proper electrical receptacle installed by a qualified electrician.

**IMPROPER ELECTRICAL CONNECTION** of the equipment grounding conductor can result in risk of electric shock. The conductor with the green insulation (with or without yellow stripes) is the equipment grounding conductor. **DO NOT** connect the equipment grounding conductor to a live terminal if repair or replacement of the electric cord or plug is necessary.

**CHECK** with a qualified electrician or service personnel if you do not completely understand the grounding instructions, or if you are not sure the tool is properly grounded when installing or replacing a plug.

**USE ONLY A 3-WIRE EXTENSION CORD THAT HAS THE PROPER TYPE OF A 3-PRONG GROUNDING PLUG THAT MATCHES THE MACHINE'S 3-PRONG PLUG AND ALSO THE 3-POLE RECEPTACLE THAT ACCEPTS THE TOOL'S PLUG.** \* See Figures A and B.

**REPLACE A DAMAGED OR WORN CORD IMMEDIATELY.**

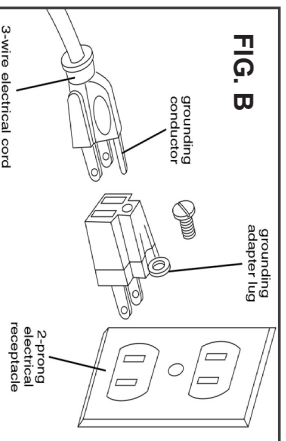
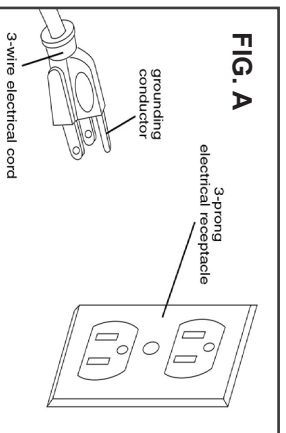

## EXTENSION CORDS

**⚠️ WARNING:** THE USE OF AN EXTENSION CORD WITH THIS MACHINE IS NOT RECOMMENDED. For best power and safety, plug the machine directly into a dedicated, grounded electrical outlet that is within the supplied cord length of the machine.

If an extension cord needs to be used, it should only be for a limited operation of the machine. The extension cord should be as short as possible in length, and have a minimum gauge size of 14AWG.

**⚠️ WARNING:** Check extension cords before each use. If damaged replace immediately. Never use a tool with a damaged cord, since touching the damaged area could cause electrical shock, and serious injury.

Use a proper extension cord. Only use cords listed by Underwriters Laboratories (UL). Other extension cords can cause a drop in line voltage, resulting in a loss of power and overheating of tool. When operating a power tool outdoors, use an outdoor extension cord marked "W-A" or "W". These cords are rated for outdoor use and reduce the risk of electric shock.

MINIMUM RECOMMENDED GAUGE FOR EXTENSION CORDS (AWG)								
120 VOLT OPERATION ONLY								
	25' LONG		50' LONG		100' LONG		150' LONG	
	0 to 6 Amps	18 AWG	16 AWG	16 AWG	16 AWG	14 AWG	14 AWG	14 AWG
6 to 10 Amps	18 AWG	16 AWG	16 AWG	14 AWG	12 AWG	12 AWG	12 AWG	12 AWG
10 to 12 Amps	16 AWG	16 AWG	16 AWG	14 AWG	12 AWG	12 AWG	12 AWG	12 AWG

**⚠️ WARNING:** Keep the extension cord clear of the working area. Position the cord so that it will not get caught on lumber, tools or other obstructions while you are working with your power tool.  
 \* Canadian electrical codes require extension cords to be certified SJT type or better.  
 \*\* The use of an adapter in Canada is not acceptable.

# SAFETY INSTRUCTIONS

## SPECIFIC SAFETY INSTRUCTIONS FOR LOG SPLITTER

This machine is intended for the cutting/splitting of wood logs. The permissible workpiece dimensions must be observed (see Technical Specification). Any other use not as specified, including modification of the machine or use of parts not tested and approved by the equipment manufacturer, can cause unforeseen damage and invalidate the warranty.

**ATTENTION:** Use of this tool still presents risks that cannot be eliminated by the manufacturer. Therefore, the user must be aware that log splitters are dangerous if not used with care and all safety precautions are adhered to.

1. **Always wear personal safety equipment** including gloves, solid anti slip working boots, eye protection and hard hat.
2. **Never** operate the log splitter on slippery, wet, muddy or icy ground to avoid personal injury.
3. **Do not** operate your log splitter in a damp or rainy environment to avoid electric shock or short circuit.
4. **Only operate** your log splitter on a level surface. Operating on a slope could cause the log splitter to roll over or cause logs to fall.
5. **Only operate** your log splitter in daylight or under good artificial light.
6. **Always keep the work area clean.** Remove split wood around your log splitter immediately to avoid pieces flying upwards and causing possible injury or stumbling over it.
7. Both ends of the log should be cut as square to help prevent the log from riding out of the splitter during operation. **Do not** split logs greater than 12" x 21" that do not fit into the work area.
8. Make sure you know to stop the log splitter and disengage the controls before operating it.
9. **Do not** reach or bend over the log splitter to pick up a log.
10. **Never** place hands, feet or any body part between the ram and splitting wedge during forward or reverse stroke. Serious injury or death could result.
11. **Do not** try to split two logs on top of each other or try to cross split a second log.
12. For safety reasons this is only to be operated by one person. **Do not** allow one person to operate while another is positioning the log.
13. **Do not** attempt to load your log splitter when the ram is in motion.
14. **Do not** move the log splitter while the motor is running. Shut off the motor and disconnect from the power supply when the log splitter is unattended.
15. **Do not** operate your log splitter when it is in poor mechanical condition or in need of repair.
16. **Always** unplug the power cable before performing any maintenance and repair. Periodically check that all nuts, bolts, screws, and platforms are tightened properly.
17. **Do not** alter your log splitter in any manner such as adding a rope or extension to the control lever or adding to the width or height of the wedge. Such alterations may cause your log splitter to be extremely unsafe and will void the warranty.

## SAVE THESE INSTRUCTIONS.

Refer to them often.

### California Proposition 65 Warning

**⚠ WARNING:** Some dust created by power sanding, sawing, grinding, drilling, and other construction activities contains chemicals known to the State of California to cause cancer and birth defects or other reproductive harm. Your risk from exposure to these chemicals varies, depending on how often you do this type of work. To reduce your exposure, work in a well-ventilated area and with approved safety equipment, such as dust masks that are specially designed to filter out microscopic particles.

For more detailed information about California Proposition 65 log onto [rikontools.com](http://rikontools.com).

**This owner's manual is not a teaching aid. Use of this owner's manual is intended to show assembly, adjustments, and general use.**

# GETTING TO KNOW YOUR LOG SPLITTER

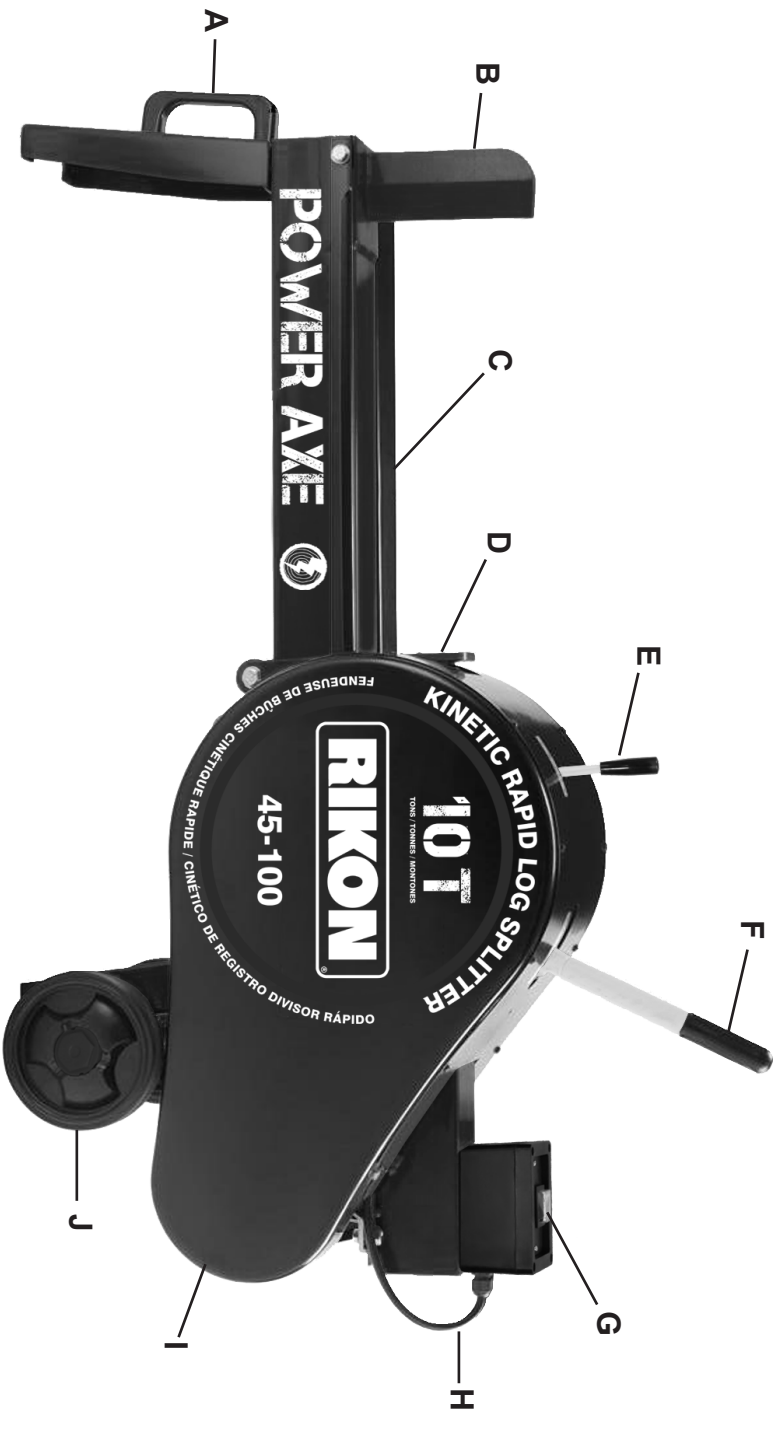

- A. Mobility Handle
- B. Splitting Wedge
- C. Carriage
- D. Ram
- E. Safety Clutch Handle
- F. Ram Release Handle
- G. On/Off Switch
- H. Power Cord
- I. Belt & Flywheel Cover (x2)
- J. Wheel (x2)
- K. Motor
- L. Drive Belt
- M. Ram Return Spring
- N. Flywheel (x2)

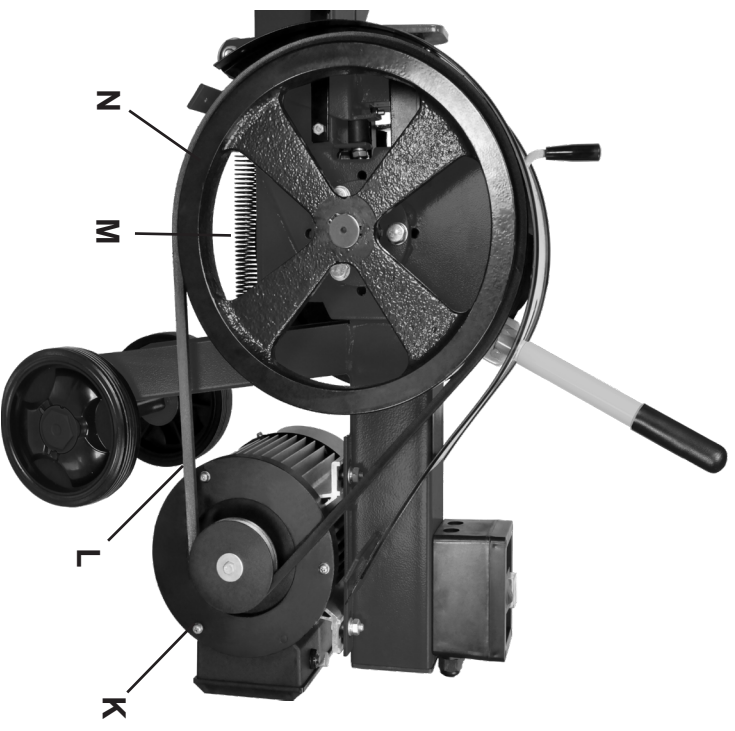

# CONTENTS OF PACKAGE / ASSEMBLY

Model 45-100 10 Ton Kinetic Rapid Log Splitter is shipped complete in one box.

## Unpacking, Checking Contents & Clean-up

1. Carefully remove all contents from the shipping carton. Compare the contents with the list of contents to make sure that all of the items are accounted for, before discarding any packing material. Place parts on a protected surface for easy identification and assembly. If any parts are missing or broken, please call RIKON Customer Service (877-884-5167) as soon as possible for replacements. **DO NOT** turn your machine **ON** if any of these items are missing. You may cause injury to yourself or damage to the machine.
2. Report any shipping damage to your local distributor. Take photos for any insurance claims.
3. With the help of another person, carefully lift the log splitter from the packaging and place it on a level floor.
4. Clean all rust protected surfaces with ordinary house hold type grease or spot remover. Do not use; gasoline, paint thinner, mineral spirits, etc. These may damage painted surfaces.
5. Set packing material and shipping carton aside. Do not discard until the machine has been set up and is running properly.

## ASSEMBLY:

The 45-100 is mostly assembled from the factory.

1. Thread the Safety Clutch Handle (B) onto the small stud protruding from the housing.
2. Thread the Ram Release Handle (C) onto the large stud below the housing.

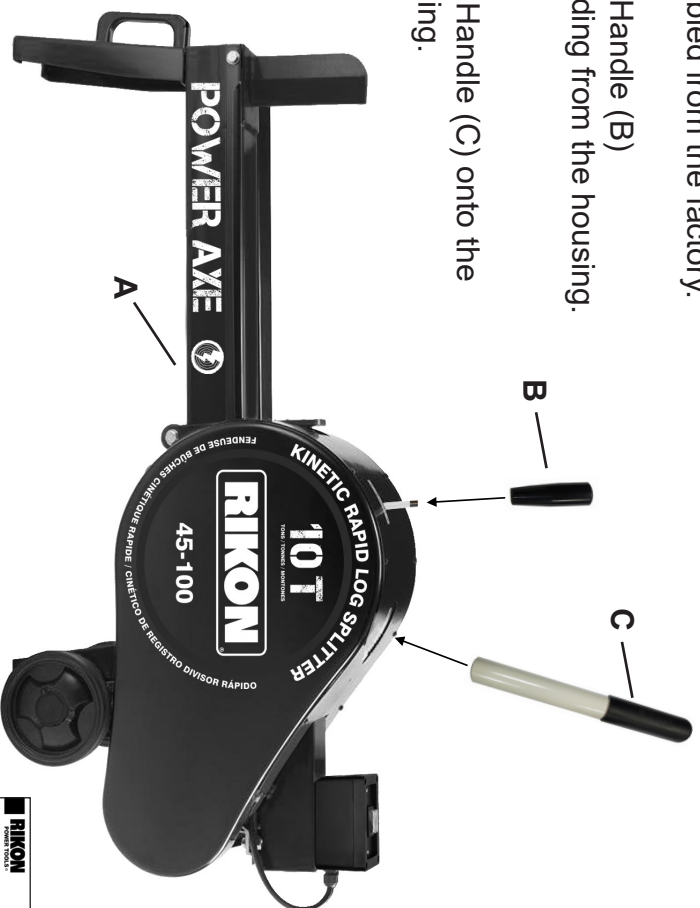

## TABLE OF LOOSE PARTS

- A. Log Splitter
- B. Safety Clutch Handle
- C. Ram Release Handle
- D. Manual

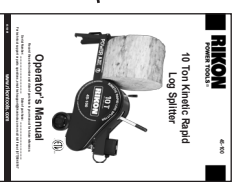



# OPERATION

**⚠ WARNING** THE MACHINE MUST NOT BE PLUGGED IN AND THE POWER SWITCH MUST BE IN THE OFF POSITION UNTIL ASSEMBLY IS COMPLETE.

**⚠ CAUTION** Operate the Log Splitter from the back of the machine for protection from splinters or pieces of wood being split; particularly from irregular or knotty wood.

**BEFORE USE:**

1. Ensure unit is on a flat and stable surface prior to operation.
2. Wear proper clothing, footwear, gloves, goggles and hearing protection.
3. Operator position is at the back of the unit behind the motor. Before use, familiarise yourself with the operating sequence by practicing without logs.
4. Maintain a clear area free from obstructions including split and unsplit logs.

**TO OPERATE:**

1. Plug the log splitter into an appropriate power source.
2. Turn on the unit and allow the motor to reach full speed.
3. Load a log onto the Carriage; forcing the log against the Splitting Wedge (Fig. 2). Be sure to split the log against the grain.

**NOTE: Do not load a log against the Ram.**  
**Do not load a log as pictured in Figure 1.**  
**Only load a log as pictured in Figure 2.**

4. Splitting a log is a two-handed operation; which promotes safety. Place one hand on the Safety Clutch Handle (#1 Fig. 3) and one hand on the Ram Release Handle (#2 Fig. 3).
5. Operate the Clutch Handle first; pushing toward the log. Once the Clutch Handle is operated and held in the forward position operate the Ram Release Handle forward towards the log. The Ram will release and push the log through the Splitting Wedge.
6. Release both handles and the Ram will retract, reloading for the next splitting operation.
7. If the log is partially split (Knock) or stuck on the Splitting Wedge repeat step five above.

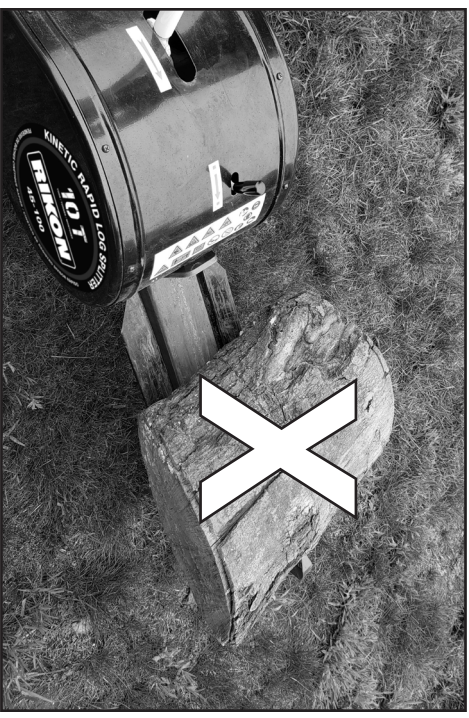

FIGURE 1



FIGURE 2



FIGURE 3

## MAINTENANCE

**CAUTION** BEFORE CLEANING OR CARRYING OUT MAINTENANCE WORK, DISCONNECT THE MACHINE FROM THE POWER SOURCE (WALL SOCKET). DO NOT USE COMPRESSED AIR NEAR BEARINGS. REGULAR MAINTENANCE OF THE MACHINE WILL PREVENT UNNECESSARY PROBLEMS.

1. Before each use, check all the nuts and bolts have been fastened and are tight, ensure the machine is in good condition before use.
2. During use, the area beneath the ram can accumulate debris and splinters which can prevent the ram returning fully to the start position. Keep this area clear from debris to ensure correct operation.
3. A build up of debris can occur under the carriage where the bearings operate. Keep this part of the machine clean.
4. Lubricate the surface of beam, the meshing parts of the Rack (PT#103) and Pinion Gear (PT#23) with light machine oil weekly or every 30 hours. For other metal parts, use a little oil to prevent rust.

**NOTE:** Parts referenced throughout the manual refer to the key numbers of the Parts Diagram and Parts List on pages 12 & 13.

### REPLACE / ADJUST DRIVE BELT:

1. Unplug the log splitter.
2. Remove the left and right Belt Covers by loosening two 10mm bolts (PT#100) and six Phillips head screws (PT#102) per cover.
3. Remove the Safety Clutch and Ram Release Handles.
4. Loosen the four 13mm Hex Nuts (PT#92) and slide the motor towards the Flywheel (PT#97), Figure 4.
5. Remove the Drive Belt (PT#62) from the Motor Pulley (PT#31) and the Flywheel (PT#97).
6. Replace the Drive Belt and tension per instructions in the next step.
7. Tension the Drive Belt by sliding the motor away from the Flywheel. Adjust the Drive Belt until there is 3/8" deflection. Figure 5.
8. Once proper deflection is reached, tighten the four 13mm Hex Nuts securing the motor.
9. Replace the left and right Belt Covers and the Safety Clutch and Ram Release Handles by reversing steps 2 & 3.

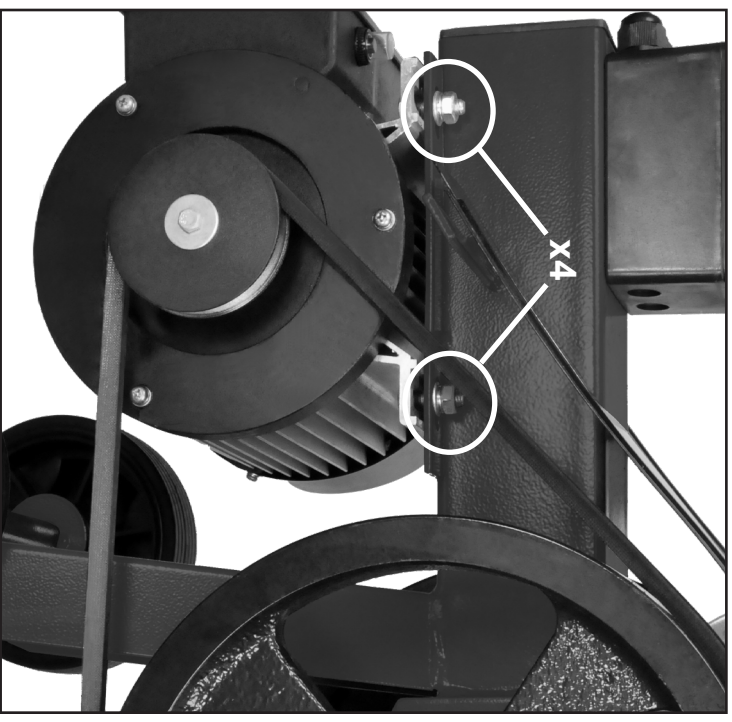

FIGURE 4

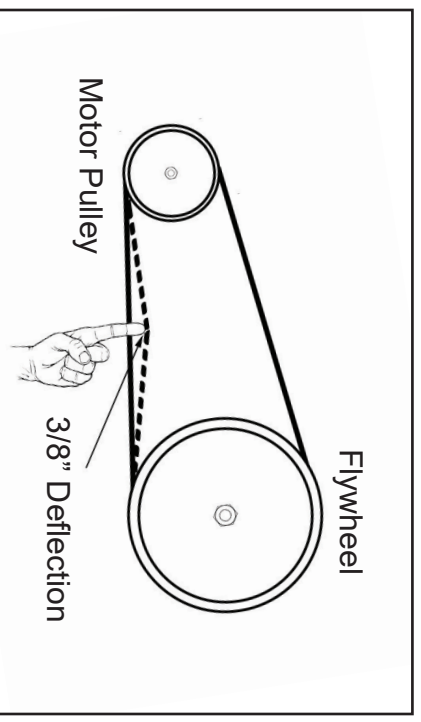

FIGURE 5

## TROUBLESHOOTING

SYMPTOM	POSSIBLE CAUSES	SOLUTIONS
Log Splitter will not start	<ol style="list-style-type: none"> <li>1. Power cord is not plugged in</li> <li>2. Fuse or circuit tripped</li> <li>3. Damaged power cord</li> <li>4. Burnt or failed switch</li> </ol>	<ol style="list-style-type: none"> <li>1. Plug in saw to power source</li> <li>2. Replace fuse or reset breaker</li> <li>3. Contact Technical Support 877-884-5167 or techsupport@rikontools.com</li> <li>4. Contact Technical Support 877-884-5167 or techsupport@rikontools.com</li> </ol>
Log fails to split	<ol style="list-style-type: none"> <li>1. Log positioned incorrectly on carriage</li> <li>2. Log exceeds size allowed to be split</li> <li>3. Large knot in log</li> </ol>	<ol style="list-style-type: none"> <li>1. Re-position log on carriage against wedge</li> <li>2. Permitted log size is 12"x21"</li> <li>3. Repeat splitting function with log in place</li> </ol>
Ram will not retract or will retract slow	<ol style="list-style-type: none"> <li>1. Debris in the rack system</li> <li>2. Return spring is damaged or worn</li> </ol>	<ol style="list-style-type: none"> <li>1. Clean / lube rack system periodically</li> <li>2. Inspect / replace return spring</li> </ol>
Drive belt noise during start up or splitting operation	<ol style="list-style-type: none"> <li>1. Drive belt is loose</li> <li>2. Drive belt is worn</li> <li>3. Drive belt is wet from outdoor use</li> </ol>	<ol style="list-style-type: none"> <li>1. Tighten drive belt tension</li> <li>2. Replace drive belt</li> <li>3. Dry and clean drive belt</li> </ol>

## WIRING DIAGRAM

### **⚠️ WARNING**

This machine must be grounded. Replacement of the power supply cable should only be done by a qualified electrician. **DO NOT** perform maintenance if water is present. See page 5 for additional electrical information.

As received from the factory, your Log Splitter is ready to run at 120V operation.

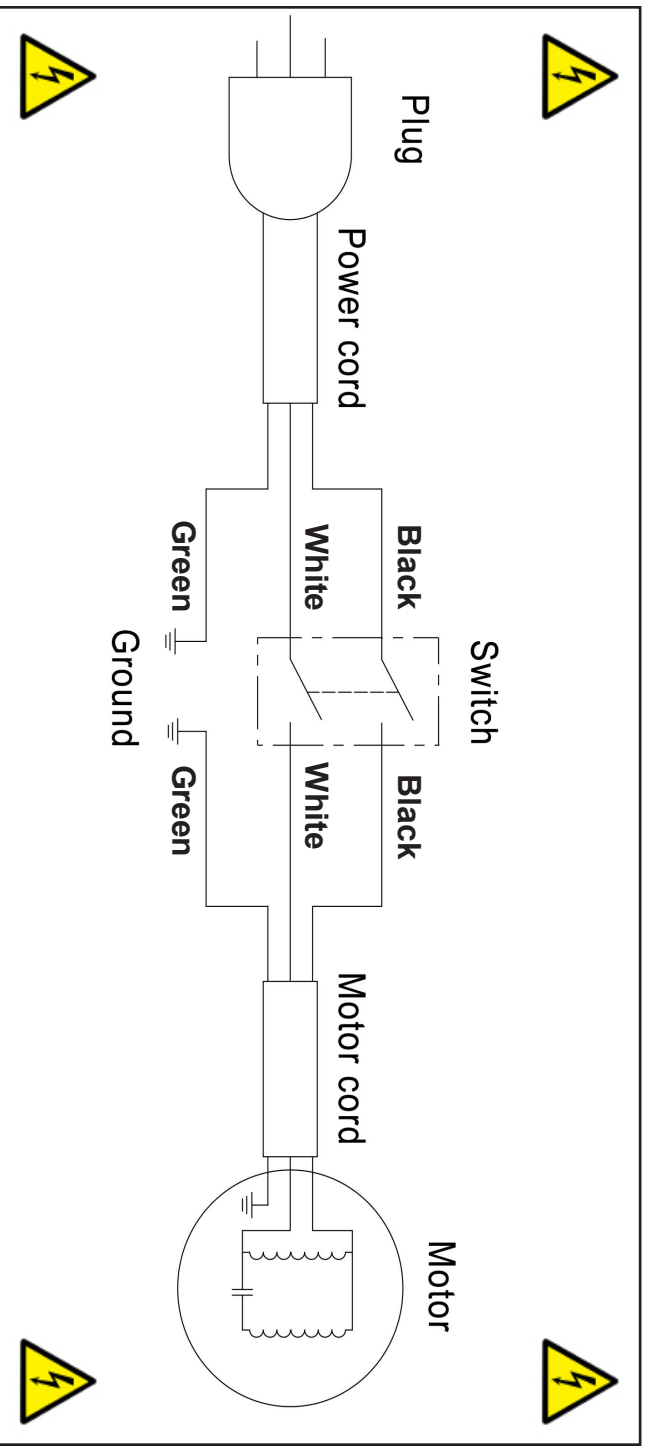



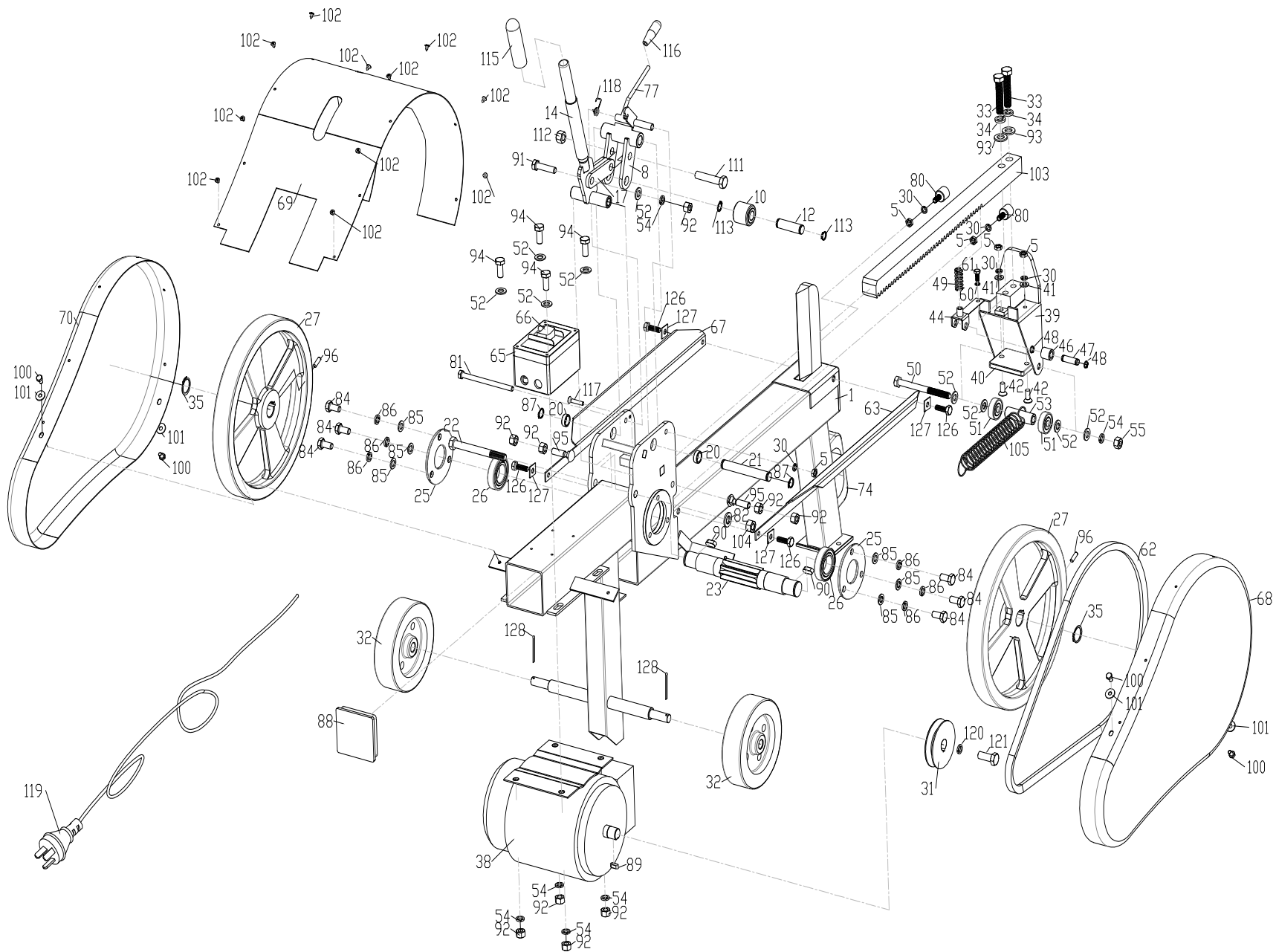



KEY NO.	DESCRIPTION	PART NO.	KEY NO.	DESCRIPTION	PART NO.
1	Frame	P45-100-1	67	Right cradle	P45-100-67
5	Hex. nut	P45-100-5	68	Right belt cover	P45-100-68
8	Connecting rod A	P45-100-8	69	Center belt cover	P45-100-69
10	Rack roller	P45-100-10	70	Left belt cover	P45-100-70
12	Rack roller shaft	P45-100-12	74	Handle	P45-100-74
14	Handle	P45-100-14	77	Safety lever	P45-100-77
17	Connecting rod B	P45-100-17	80	Bumper	P45-100-80
20	Bushing	P45-100-20	81	Hex. bolt	P45-100-81
21	Shaft	P45-100-21	82	Washer	P45-100-82
22	Hex. bolt	P45-100-22	84	Hex. bolt	P45-100-84
23	Pinion gear	P45-100-23	85	Washer	P45-100-85
25	Bearing cover	P45-100-25	86	Spring washer	P45-100-86
26	Ball bearing	P45-100-26	87	Retaining ring/shaft	P45-100-87
27	Flywheel	P45-100-27	88	End cap	P45-100-88
30	Spring washer	P45-100-30	89	Key	P45-100-89
31	Motor pulley	P45-100-31	90	Key	P45-100-90
32	Wheel	P45-100-32	91	Hex. bolt	P45-100-91
33	Hex. bolt	P45-100-33	92	13mm Hex Nuts	P45-100-92
34	Spring washer	P45-100-34	93	Washer	P45-100-93
35	Retaining ring/shaft	P45-100-35	94	Hex. bolt	P45-100-94
38	Motor	P45-100-38	95	Hex. bolt	P45-100-95
39	Pusher	P45-100-39	96	Set screw	P45-100-96
40	Wear resistant mat	P45-100-40	100	Hex. bolt	P45-100-100
41	Washer	P45-100-41	101	Washer	P45-100-101
42	Hex. bolt	P45-100-42	102	Self tapping screw	P45-100-102
44	Roller bracket	P45-100-44	103	Rack	P45-100-103
46	Roller	P45-100-46	104	Hex. nut	P45-100-104
47	Roller shaft	P45-100-47	105	Retract spring	P45-100-105
48	Retaining ring/shaft	P45-100-48	111	Hex. bolt	P45-100-111
49	Rack spring	P45-100-49	112	Hex. nut	P45-100-112
50	Hex. bolt	P45-100-50	113	Retaining ring/shaft	P45-100-113
51	Ball bearing	P45-100-51	115	Handle grip	P45-100-115
52	Washer	P45-100-52	116	Knob	P45-100-116
53	Bearing sleeve	P45-100-53	117	Screw	P45-100-117
54	Spring washer	P45-100-54	118	Spring	P45-100-118
55	Hex. nut	P45-100-55	119	Power cord	P45-100-119
60	Spring washer	P45-100-60	120	Large washer	P45-100-120
61	Hex. bolt	P45-100-61	121	Hex. bolt	P45-100-121
62	V-belt	P45-100-62	126	Hex. bolt	P45-100-126
63	Left cradle	P45-100-63	127	Square spacer	P45-100-127
65	Switch box	P45-100-65	128	Cotter pin	P45-100-128
66	Switch	P45-100-66			

**NOTE:** Please reference the Manufacturer's Part Number when calling for Replacement Parts. For Parts under Warranty, the Serial Number of your machine is required.



# RIKON

## POWER TOOLS®

### 2-Year Limited Warranty

RIKON Power Tools Inc. ("Seller") warrants to only the original retail consumer/purchaser of our products that each product be free from defects in materials and workmanship for a period of two (2) years from the date the product was purchased at retail. This warranty may not be transferred.

This warranty does not apply to defects due directly or indirectly to misuse, abuse, negligence, accidents, repairs, alterations, lack of maintenance or normal wear and tear. Under no circumstances will Seller be liable for incidental or consequential damages resulting from defective products. All other warranties, expressed or implied, whether of merchantability, fitness for purpose, or otherwise are expressly disclaimed by Seller. This warranty also covers products used for commercial, industrial or educational purposes. The warranty for these claims will be limited to a one-year period.

This limited warranty does not apply to accessory items such as blades, drill bits, sanding discs, grinding wheels, guide bearings, belts and other related items.

Seller shall in no event be liable for death, injuries to persons or property, or for incidental, contingent, special, or consequential damages arising from the use of our products.

# 2-YEAR WARRANTY

To take advantage of this warranty proof of purchase documentation, which includes date of purchase and an explanation of the complaint, must be provided.

The Seller reserves the right to effect at any time, without prior notice, those alterations to parts, fittings, and accessory equipment which they may deem necessary for any reason whatsoever.

To register your machine online, visit RIKON at [www.rikontools.com/warranty](http://www.rikontools.com/warranty)

To take advantage of this warranty, or if you have any questions, please contact us at  
877-884-5167 or email [warranty@rikontools.com](mailto:warranty@rikontools.com)

**RIKON**  
POWER TOOLS®

45-100



**For more information:  
16 Progress Road  
Billerica, MA 01821**

**877-884-5167 / 978-528-5380  
techsupport@rikontools.com**

