

2" x 72" Belt Sander/Buffer

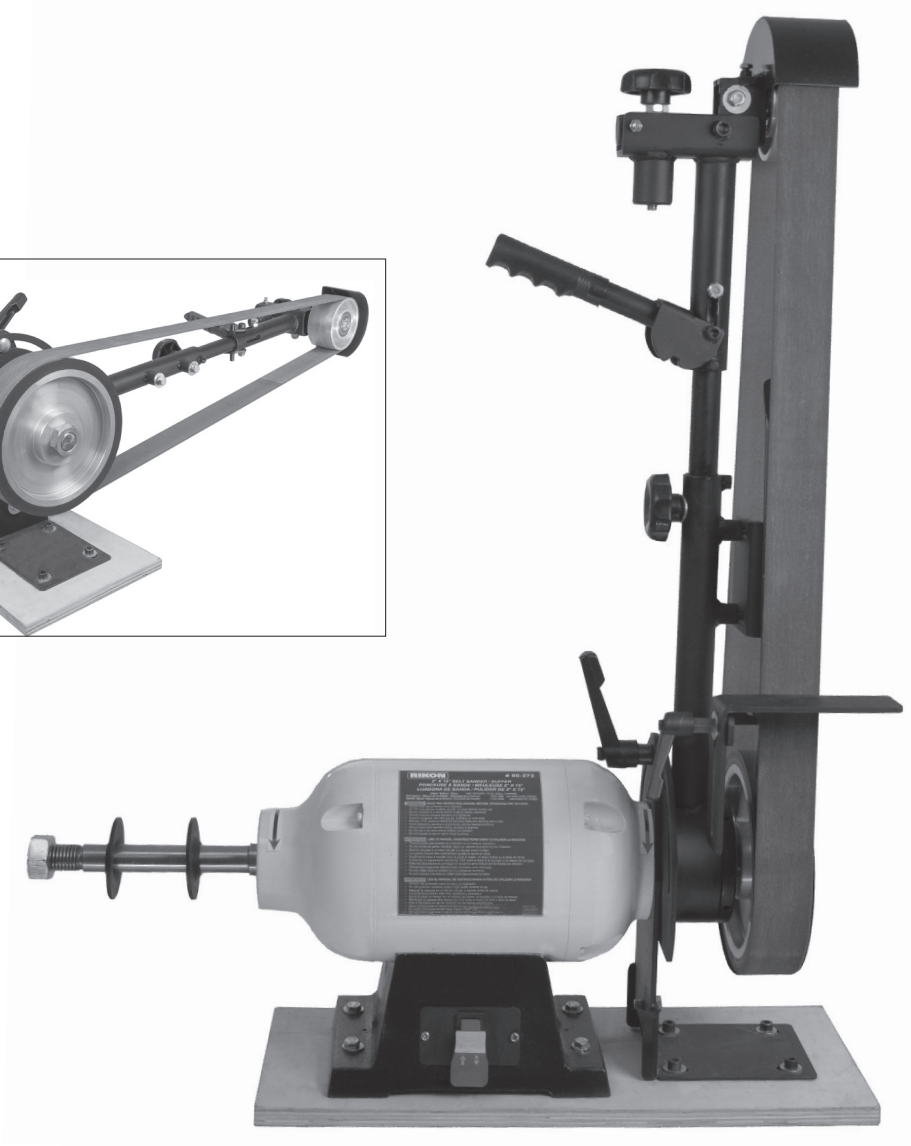
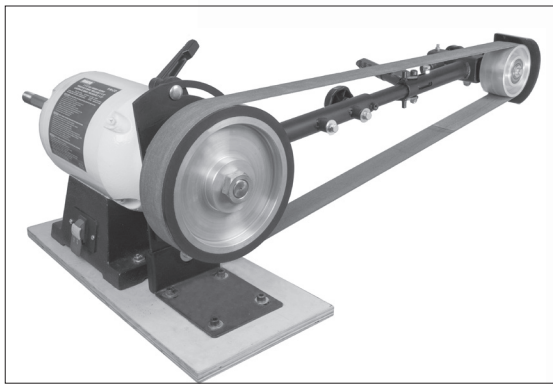

Operator's Manual

Record the serial number and date of purchase in your manual for future reference.

Serial Number: _____ Date of purchase: _____

For technical support or parts questions, email techsupport@rikontools.com or call toll free at (877) 884-5167

TABLE OF CONTENTS

Specifications	2
Safety Instructions.....	3 - 6
Electrical Requirements	5, 16
Sander Safety Rules	6
Contents of Package	7
Getting to Know Your Sander	8
Installation	8
Assembly	8 - 10, 17
Adjustments	10 - 12
General Use.....	12 - 13
Troubleshooting.....	14 - 15
Maintenance	15
Wiring Diagram.....	16
Warranty	16
Accessories	17
Parts Diagram	18
Parts List	19

SPECIFICATIONS #50-272

Motor	1HP, 110/220V, 14/7A, 60Hz, 1Ph
Motor Speed	1,720 RPM
Belt Size	2" x 72" or 2" x 76"
Belt Speed	3,600 SFPM
Belt Arm Tilt	0-90-0°
Belt Table Size	5-1/2" x 2"
Belt Table Tilt	90 to - 150+°
Platen Size	10-3/8" x 2"
Drive Wheel Size	8" x 2"
Idler Wheel Size	4" x 2"
Spindle Size	1" Diameter x 8" Length
Spindle Thread	2" Long, 1"x8 UNC (LH & RH)
Spindle Height from Base	7-1/2"
Machine Height	36-3/4"
Machine Width	30"
Machine Depth	10-3/4"
2 Bases Assembled Size	7" x 17-1/2"
Power Cord with 110V Plug	7 ft., 16 Gauge
Minimum Circuit Size	15 Amp
Net Weight	68 lbs.
Shipping Weight	73 lbs.
Shipping Carton	29-1/2" x 19" x 13-1/2"

This owner's manual is not a teaching aid and is intended to show assembly, adjustments, and general use.

NOTE: The specifications, photographs, drawings and information in this manual represent the current model when the manual was prepared. Changes and improvements may be made at any time, with no obligation on the part of RIKON Power Tools, Inc. to modify previously delivered units. Reasonable care has been taken to ensure that the information in this manual is correct, to provide you with the guidelines for the proper safety, assembly and operation of this machine.

SAFETY SYMBOLS

IMPORTANT! Safety is the single most important consideration in the operation of this equipment. **The following instructions must be followed at all times.** Failure to follow all instructions listed below may result in electric shock, fire, and/or serious personal injury.

There are certain applications for which this tool was designed. We strongly recommend that this tool not be modified and/or used for any other application other than that for which it was designed. If you have any questions about its application, do not use the tool until you have contacted us and we have advised you.

SAFETY SYMBOLS



SAFETY ALERT SYMBOL: Indicates DANGER, WARNING, or CAUTION. This symbol may be used in conjunction with other symbols or pictographs.



Indicates an imminently hazardous situation, which, if not avoided, could result in death or serious injury.



Indicates a potentially hazardous situation, which, if not avoided, could result in death or serious injury.



Indicates a potentially hazardous situation, which, if not avoided, could result in minor or moderate injury.

NOTICE: Shown without Safety Alert Symbol indicates a situation that may result in property damage.

GENERAL SAFETY

KNOW YOUR POWER TOOL. Read the owner's manual carefully. Learn the tool's applications, work capabilities, and its specific potential hazards.

BEFORE USING YOUR MACHINE

To avoid serious injury and damage to the tool, read and follow all of the Safety and Operating Instructions before operating the machine.

1. **WARNING** Some dust created by using power tools contains chemicals known to the State of California to cause cancer, birth defects, or other reproductive harm. Some examples of these chemicals are:

- Lead from lead-based paints.
- Crystalline silica from bricks, cement, and other masonry products.
- Arsenic and chromium from chemically treated lumber.

Your risk from these exposures varies, depending on how often you do this type of work. To reduce your exposure to these chemicals: work in a well ventilated area and work with approved safety equipment, such as those dust masks that are specially designed to filter out microscopic particles.

2. **READ** the entire Owner's Manual. **LEARN** how to use the tool for its intended applications.

3. **GROUND ALL TOOLS.** If the tool is supplied with a 3 prong plug, it must be plugged into a 3-contact electrical receptacle. The 3rd prong is used to ground the tool and provide protection against accidental electric shock. **DO NOT** remove the 3rd prong. See Grounding Instructions on the following pages.

4. **AVOID A DANGEROUS WORKING ENVIRONMENT.** **DO NOT** use electrical tools in a damp environment or expose them to rain.

5. **DO NOT** use electrical tools in the presence of flammable liquids or gases.

6. **ALWAYS** keep the work area clean, well lit, and organized. **DO NOT** work in an environment with floor surfaces that are slippery from debris, grease, and wax.

7. **KEEP VISITORS AND CHILDREN AWAY. DO NOT** permit people to be in the immediate work area, especially when the electrical tool is operating.

8. **DO NOT FORCE THE TOOL** to perform an operation for which it was not designed. It will do a safer and higher quality job by only performing operations for which the tool was intended.

9. **WEAR PROPER CLOTHING. DO NOT** wear loose clothing, gloves, neckties, or jewelry. These items can get caught in the machine during operations and pull the operator into the moving parts. The user must wear a protective cover on their hair, if the hair is long, to prevent it from contacting any moving parts.

10. **CHILDPROOF THE WORKSHOP AREA** by removing switch keys, unplugging tools from the electrical receptacles, and using padlocks.

11. **ALWAYS UNPLUG THE TOOL FROM THE ELECTRICAL RECEPTACLE** when making adjustments, changing parts or performing any maintenance.

SAFETY INSTRUCTIONS

12. KEEP PROTECTIVE GUARDS IN PLACE AND IN WORKING ORDER.

13. AVOID ACCIDENTAL STARTING. Make sure that the power switch is in the “OFF” position before plugging in the power cord to the electrical receptacle.

14. REMOVE ALL MAINTENANCE TOOLS from the immediate area prior to turning “ON” the machine.

15. USE ONLY RECOMMENDED ACCESSORIES. Use of incorrect or improper accessories could cause serious injury to the operator and cause damage to the tool. If in doubt, check the instruction manual that comes with that particular accessory.

16. NEVER LEAVE A RUNNING TOOL UNATTENDED. Turn the power switch to the “OFF” position. **DO NOT** leave the tool until it has come to a complete stop.

17. DO NOT STAND ON A TOOL. Serious injury could result if the tool tips over, or you accidentally contact the tool.

18. DO NOT store anything above or near the tool where anyone might try to stand on the tool to reach it.

19. MAINTAIN YOUR BALANCE. DO NOT extend yourself over the tool. Wear oil resistant rubber soled shoes. Keep floor clear of debris, grease, and wax.

20. MAINTAIN TOOLS WITH CARE. Always keep tools clean and in good working order. Keep all blades and tool bits sharp, dress grinding wheels and change other abrasive accessories when worn.

21. EACH AND EVERY TIME, CHECK FOR DAMAGED PARTS PRIOR TO USING THE TOOL. Carefully check all guards to see that they operate properly, are not damaged, and perform their intended functions. Check for alignment, binding or breaking of moving parts. A guard or other part that is damaged should be immediately repaired or replaced.

22. DO NOT OPERATE TOOL WHILE TIRED, OR UNDER THE INFLUENCE OF DRUGS, MEDICATION OR ALCOHOL.

23. SECURE ALL WORK. Use clamps or jigs to secure the work piece. This is safer than attempting to hold the work piece with your hands.

24. STAY ALERT, WATCH WHAT YOU ARE DOING, AND USE COMMON SENSE WHEN OPERATING A POWER TOOL.
A moment of inattention while operating power tools may result in serious personal injury.

25. ALWAYS WEAR A DUST MASK TO PREVENT INHALING DANGEROUS DUST OR AIRBORNE PARTICLES, including wood dust, crystalline silica dust and asbestos dust. Direct particles away from face and body. Always operate tool in well ventilated area and provide for proper dust removal. Use dust collection system wherever possible. Exposure to the dust may cause serious and permanent respiratory or other injury, including silicosis (a serious lung disease), cancer, and death. Avoid breathing the dust, and avoid prolonged contact with dust. Allowing dust to get into your mouth or eyes, or lay on your skin may promote absorption of harmful material. Always use properly fitting NIOSH/OSHA approved respiratory protection appropriate for the dust exposure, and wash exposed areas with soap and water.

26. USE A PROPER EXTENSION CORD IN GOOD CONDITION. When using an extension cord, be sure to use one heavy enough to carry the current your product will draw. The table on the following page shows the correct size to use depending on cord length and nameplate amperage rating. If in doubt, use the next heavier gauge. The smaller the gauge number, the larger diameter of the extension cord. If in doubt of the proper size of an extension cord, use a shorter and thicker cord. An undersized cord will cause a drop in line voltage resulting in a loss of power and overheating.
USE ONLY A 3-WIRE EXTENSION CORD THAT HAS A 3-PRONG GROUNDING PLUG AND A 3-POLE RECEPTACLE THAT ACCEPTS THE TOOL’S PLUG.

27. ADDITIONAL INFORMATION regarding the safe and proper operation of this product is available from:

- Power Tool Institute
1300 Summer Avenue
Cleveland, OH 44115-2851
www.powertoolinstitute.org
- National Safety Council
1121 Spring Lake Drive
Itasca, IL 60143-3201
www.nsc.org
- American National Standards Institute
25 West 43rd Street, 4th Floor
New York, NY 10036
www.ansi.org
- ANSI 01.1 Safety Requirements for Woodworking Machines and the U.S. Department of Labor regulations
www.osha.gov

28. SAVE THESE INSTRUCTIONS. Refer to them frequently and use them to instruct others.

SAFETY INSTRUCTIONS

ELECTRICAL SAFETY

⚠️ WARNING: THIS TOOL MUST BE GROUNDED WHILE IN USE TO PROTECT THE OPERATOR FROM ELECTRIC SHOCK.

IN THE EVENT OF A MALFUNCTION OR BREAKDOWN, grounding provides the path of least resistance for electric current and reduces the risk of electric shock. This tool is equipped with an electric cord that has an equipment grounding conductor and requires a grounding plug (not included). The plug **MUST** be plugged into a matching electrical receptacle that is properly installed and grounded in accordance with **ALL** local codes and ordinances.

DO NOT MODIFY ANY PLUG. If it will not fit the electrical receptacle, have the proper electrical receptacle installed by a qualified electrician.

IMPROPER ELECTRICAL CONNECTION of the equipment grounding conductor can result in risk of electric shock. The conductor with the green insulation (with or without yellow stripes) is the equipment grounding conductor. **DO NOT** connect the equipment grounding conductor to a live terminal if repair or replacement of the electric cord or plug is necessary.

CHECK with a qualified electrician or service personnel if you do not completely understand the grounding instructions, or if you are not sure the tool is properly grounded when installing or replacing a plug.

USE ONLY A 3-WIRE EXTENSION CORD THAT HAS THE PROPER TYPE OF A 3-PRONG GROUNDING PLUG THAT MATCHES THE MACHINE'S 3-PRONG PLUG AND ALSO THE 3-POLE RECEPTACLE THAT ACCEPTS THE TOOL'S PLUG. *

REPLACE A DAMAGED OR WORN CORD IMMEDIATELY.

This tool is intended for use on a circuit that has an electrical receptacle as shown in **FIGURE A**. It shows a 3-wire electrical plug and electrical receptacle that has a grounding conductor. If a properly grounded electrical receptacle is not available, an adapter as shown in **FIGURE B** can be used to temporarily connect this plug to a 2-contact ungrounded receptacle. The adapter has a rigid lug extending from it that **MUST** be connected to a permanent earth ground, such as a properly grounded receptacle box. **THIS ADAPTER IS PROHIBITED IN CANADA.** **FIGURE C** shows the type of the 220V, 3-wire electrical plug and receptacle that has a grounding conductor that is required if the motor wiring is changed.

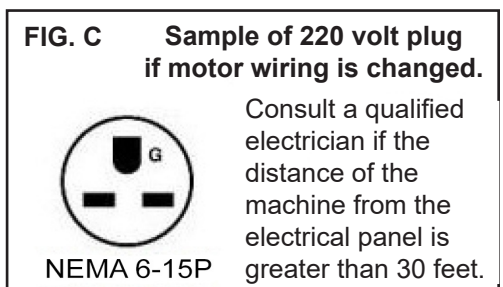
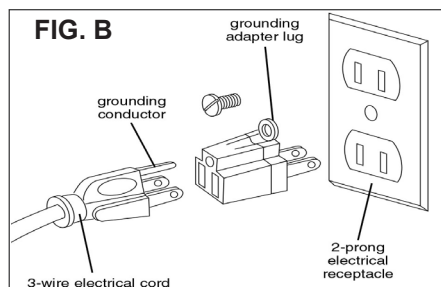
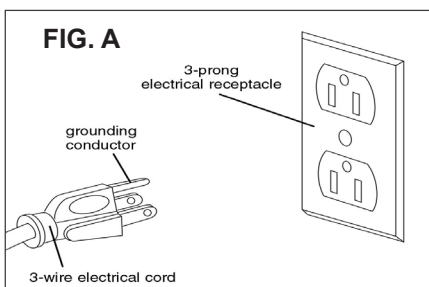

EXTENSION CORDS

⚠️ WARNING: THE USE OF AN EXTENSION CORD WITH THIS MACHINE IS NOT RECOMMENDED. For best power and safety, plug the machine directly into a dedicated, grounded electrical outlet that is within the supplied cord length of the machine.

If an extension cord needs to be used, it should only be for a limited operation of the machine. The extension cord should be as short as possible in length, and have a minimum gauge size of 14AWG.

⚠️ WARNING: Check extension cords before each use. If damaged replace immediately. Never use a tool with a damaged cord, since touching the damaged area could cause electrical shock, resulting in serious injury.

Use a proper extension cord. Only use cords listed by Underwriters Laboratories (UL). Other extension cords can cause a drop in line voltage, resulting in a loss of power and overheating of tool. When operating a power tool outdoors, use an outdoor extension cord marked "W-A" or "W". These cords are rated for outdoor use and reduce the risk of electric shock.

MINIMUM RECOMMENDED GAUGE FOR EXTENSION CORDS (AWG)

120 VOLT OPERATION ONLY				
	25' LONG	50' LONG	100' LONG	150' LONG
0 to 6 Amps	18 AWG	16 AWG	16 AWG	14 AWG
6 to 10 Amps	18 AWG	16 AWG	14 AWG	12 AWG
10 to 12 Amps	16 AWG	16 AWG	14 AWG	12 AWG

⚠️ WARNING: Keep the extension cord clear of the working area. Position the cord so that it will not get caught on lumber, tools or other obstructions while you are working with your power tool.

* Canadian electrical codes require extension cords to be certified SJT type or better.

** The use of an adapter in Canada is not acceptable.

SAFETY INSTRUCTIONS

This machine is intended for the surfacing of woods, metals and composite materials. Any other use not as specified, including modification of the machine or use of parts not tested and approved by the equipment manufacturer can cause unforeseen damage, and invalidate the warranty.

ATTENTION: Use of this sander still presents risks that cannot be eliminated by the manufacturer. Therefore, the user must be aware that wood working machines are dangerous if not used with care and all safety precautions are adhered to.

1. Do not operate this machine until you have read all of the following instructions.
2. Do not attempt to operate this machine until it is completely assembled.
3. Do not turn ON this machine if any pieces are damaged or missing.
4. This machine must be properly grounded.
5. If you are not familiar with the operation of the machine, obtain assistance from a qualified person.
6. This machine MUST be firmly mounted to a flat and secure work surface or stand.
7. Always wear ANSI approved protective eye wear prior to operating this machine.
8. Always wear a dust mask and use adequate dust collection and proper ventilation. This machine can produce harmful particles while sanding or buffing certain types of woods, metals or other materials.
9. Do not wear loose clothing or jewelry when operating this machine. Keep long hair tied back.
10. Always make sure the power switch is in the OFF position prior to plugging in the machine.
11. Always make sure the power switch is in the OFF position when doing any assembly or setup operation.
12. Make sure all safety guards and hardware are securely tightened before operating the machine.
13. The use of any accessories or attachments not recommended may cause injury to you and damage your machine.
14. Abrasive belts and buffs should be the recommended width and length of the manufacturer.
15. Replace worn, frayed or torn abrasives or wheels, as injury to the user, or the machine, may result.
16. Always keep your face and hands clear of moving parts such as belts, discs, wheels and pulleys.
17. Keep power supply cords free of moving parts of the sander. Damaged cords can result in electric shock.
18. Maintain a minimal gap clearance (1/16" or less) between the sanding belt and the work table.
19. Always support the workpiece with the table or backstop during sanding.
20. Securely hold workpieces being buffed and worked only in the lower front 'work area' of the buffing wheel.
21. Rotating buffing wheels can cause burns and abrasions if contacted by bare flesh. Wear gloves when working.
22. Carefully feed work into the rotating sanding belt, or disc, on the downward direction, so that the abrasive action pushes the work down onto the tables where it can be controlled.
23. Do not force the work into the abrasives, as burning of the wood or stalling of the machine may result.
24. Remove material or debris from the work area. Keep work area neat and clean.

SAVE THESE INSTRUCTIONS. Refer to them often.

This owner's manual is not a teaching aid and is intended to show assembly, adjustments, and general use.



CALIFORNIA PROPOSITION 65 WARNING: Some dust created by power sanding, sawing, grinding, drilling, buffing, metal finishing and other construction activities contains chemicals known to the State of California to cause cancer and birth defects or other reproductive harm. Your risk from exposure to these chemicals varies, depending on how often you do this type of work. To reduce your exposure, work in a well-ventilated area and with approved safety equipment, such as dust masks that are specially designed to filter out microscopic particles.

For more detailed information about California Proposition 65 log onto rikontools.com.

CONTENTS OF PACKAGE

UNPACKING AND CLEAN-UP

1. Carefully remove all contents from the shipping carton. Compare the contents with the list of contents to make sure that all of the items are accounted for, before discarding any packing material. Place parts on a protected surface for easy identification and assembly. If any parts are missing or broken, please call RIKON Customer Service (877-884-5167) as soon as possible for replacements. DO NOT turn your machine ON if any of these items are missing. You may cause injury to yourself or damage to the machine.
2. Report any shipping damage to your local distributor. Take photographs for any possible insurance claims.
3. Clean all rust protected surfaces with ordinary house hold type grease or spot remover. Do not use; gasoline, paint thinner, mineral spirits, etc. These may damage painted surfaces.
4. Apply a coat of paste wax to the table to prevent rust. Wipe all parts thoroughly with a clean dry cloth.
5. Set packing material and shipping carton aside. Do not discard until the machine has been set up and is running properly.

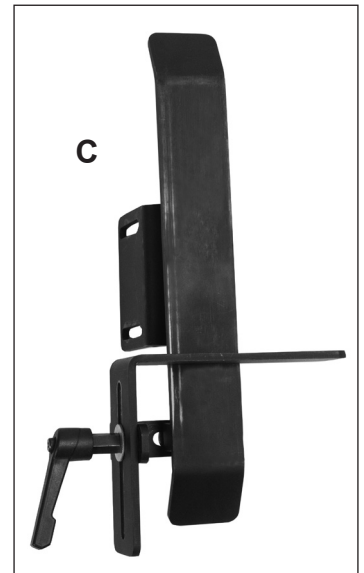
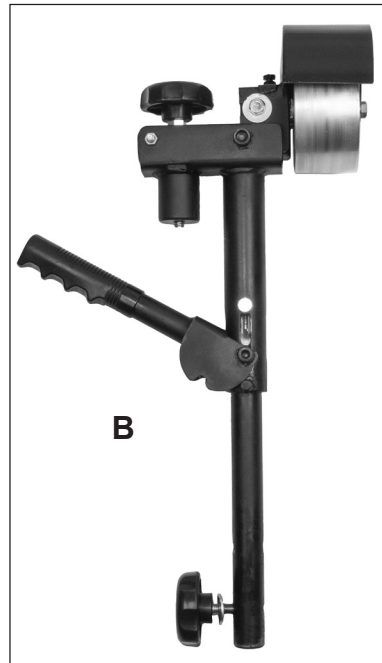
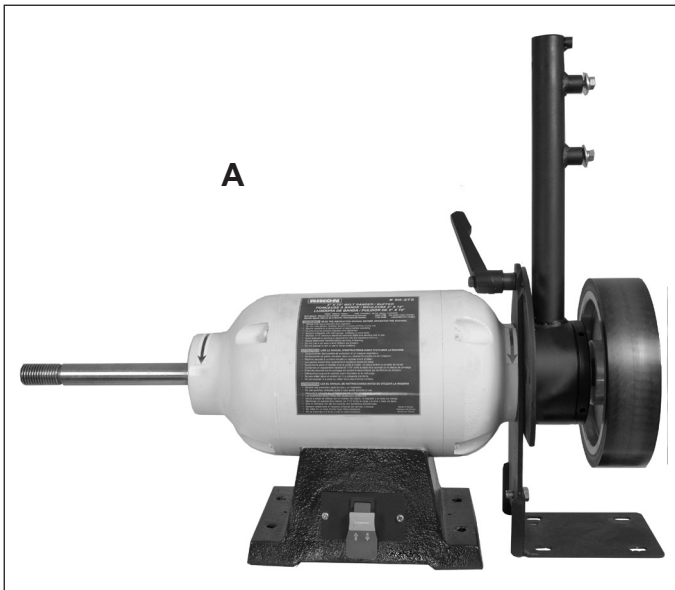
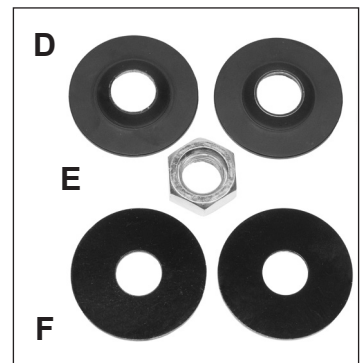
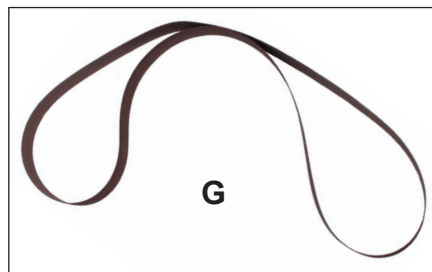

TABLE OF LOOSE PARTS

- A. Motor & Drive Wheel Assembly
 - B. Upper Idler Wheel Assembly
 - C. Platen & Table Assembly
 - D. Cupped Flanges for Spindle (2)
 - E. 1" x 8UNC Nut for Spindle
 - F. Flat Flanges for Threaded Spindle End (2)
 - G. 2" x 72" Abrasive Sanding Belt
- Template for Drilling Mounting Holes (not shown)
 - Manual (not shown)



Tools Required for Assembly:

- 1/2" & 9/16" (12mm & 14mm) Wrenches
- Hardware for mounting the machine on a stand or workbench (not supplied)

See pages 18 - 19 for the full Parts Diagram and Parts List

GETTING TO KNOW YOUR SANDER

#50-272
2" x 72"
Belt Sander
/ Buffer

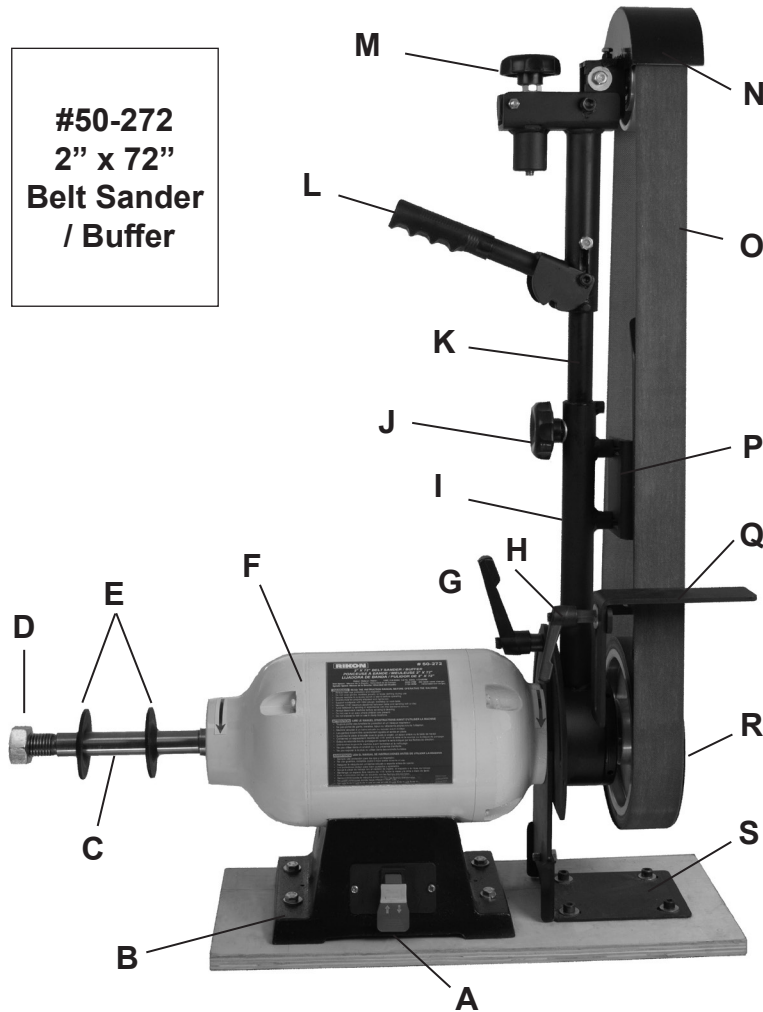

- A. ON/OFF Safety Switch
- B. Motor Base with Mounting Holes
- C. Buffing/Sanding 1" x 8" Spindle
- D. Hex Nut 1" - UNC L.H.
- E. Flanges
- F. Motor Assembly
- G. Locking Handle to Pivot Sanding Assembly Vertical to Horizontal
- H. Locking Handle for Tool Rest
- I. Pivot Arm Assembly
- J. Knob to Adjust Sanding Arm Assembly Height for Belts
- K. Sanding Arm Assembly
- L. Belt Tension Lever
- M. Belt Alignment Knob
- N. 4" Idler Wheel with Sanding Belt Safety Cover
- O. Sanding Belt
- P. Platen Assembly
- Q. Tool Rest Assembly
- R. 8" Drive Wheel
- S. Sanding Arm Assembly Bracket

Machine shown mounted on plywood base
(base and hardware not included)

INSTALLATION

MOVING & INSTALLING THE SANDER

CAUTION When moving the sander, lift the machine with your hands positioned under the motor ends or base. DO NOT carry or move it using the attached work table or sanding arm.

1. The machine should be firmly bolted to a stand or solid, level workbench to avoid any movement of the machine during use. The sander's bases have holes for this purpose (mounting hardware is not included).

For portability and secure clamping of the sander to a workbench, the machine can be first permanently

bolted to a piece of plywood. Then the sander can be positioned on your workbench, or other solid surface, and the plywood can be clamped in place to secure the sander for use. After use, the plywood can be unclamped and the sander stored for future use.

2. When positioning the machine for work, locate it in an area that has ample space around the sander for the moving of projects to be sanded. Align the machine so that it will not face aisles, doorways, or other work areas that bystanders may be in. Do not locate or use the machine in damp or wet conditions. Use a Dust Collector to capture the fine dust that is created when sanding. See the safety instructions.

ASSEMBLY

Tools Required for Assembly:

- 1/2" & 9/16" (12mm & 14mm) Wrenches
- Hardware for mounting machine on a stand or workbench (not supplied)

ASSEMBLY

ASSEMBLING THE BELT SANDER

⚠️ WARNING: The 50-272 Belt Sander / Buffer is a top-heavy machine and needs to be bolted down to prevent it from tipping over during use. Have your work stand, bench or a thick piece of plywood ready to mount the sander for assembly.

MOUNTING THE SANDER TO A WORKBENCH

CAUTION: the sander must be properly mounted at a suitable, safe height for your sanding work to be carried out.

1. To determine the best working location for your sander, position the motor assembly on your stand or bench. Once satisfied, use a short pencil to mark the work surface through the 4 mounting holes located in the sander's Motor Base (B), and also the 4 mounting holes in the base of the Sanding Arm Bracket (S).
2. Included with the machine, and also shown on page 17, is the Template for the drilling of the final holes to mount the sander's motor and sanding arm bracket. Use this template's dimensions along with the drawn pencil marks to determine the final mounting hole locations for the motor and bracket.
3. Remove the sander from the workbench to reveal the 8 bolt hole location marks created in step 1.
4. Review the layout of the marks with the factory Mounting Diagram dimensions. Make adjustments to the hole locations as needed.
5. Drill the 8 holes to mount the motor and bracket. The recommended drill size 10mm (3/8") should be confirmed with the diameter of your hardware (not included) to be used to secure the sander in place.
6. Mount the motor base (B) and bracket (S) assemblies onto your work surface with your hardware. Fully tighten the hardware to secure the parts in place. Figures 1 & 2.

ATTACHING THE SANDING ARM ASSEMBLY

1. Rotate the lower Pivot Arm Assembly (I) into the vertical position. This assembly is pre-installed on the motor's shaft next to the 8" Drive Wheel (R). Use the Locking Lever Handle (G) to loosen then secure the pivot arm in place. FIG. 2 & 3. CONTINUED ON PAGE 10

⚠️ WARNING THE MACHINE MUST NOT BE PLUGGED IN AND THE POWER SWITCH MUST BE IN THE OFF POSITION UNTIL FULL ASSEMBLY AND ALL ADJUSTMENTS ARE COMPLETE.

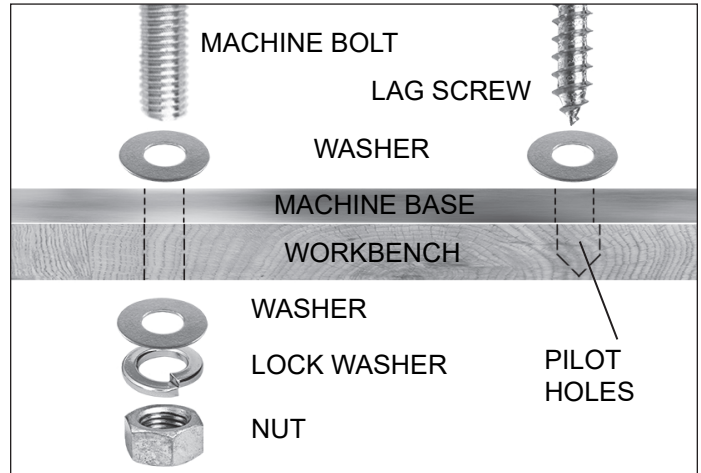

FIG. 1

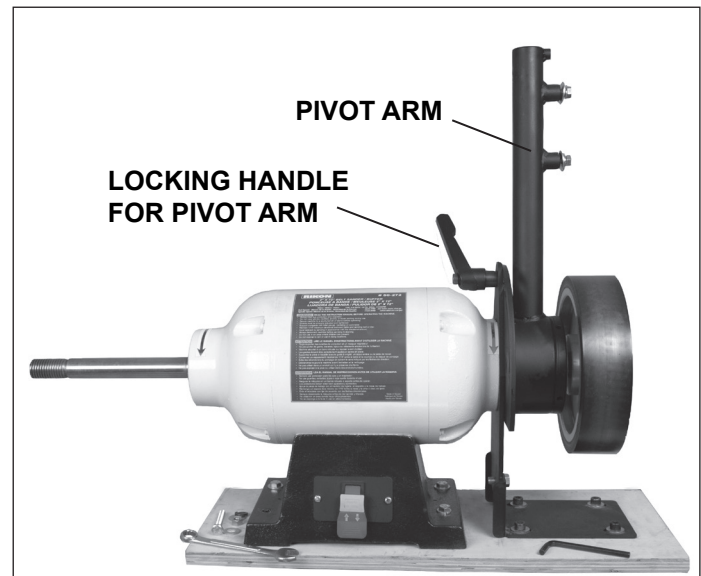

FIG. 2



FIG. 3

ASSEMBLY & ADJUSTMENTS

CONTINUED FROM PAGE 9

ATTACHING THE SANDING ARM ASSEMBLY

NOTE: The Locking Lever Handles (G & H) are spring loaded. Behind the screw in the middle of the handle there is a spring. To position the handle in a new location, just pull out the handle, rotate it to a new direction, and push the handle back onto place. The handle indexes itself on the interior bolt.

2. The upper Sanding Arm Assembly (K) attaches to the lower Pivot Arm (I) by sliding it into the top of the pivot arm's tube and is then secured in place with the Locking Handle (J). The sanding arm's top 4" Idler Wheel (N) will automatically align with the lower 8" Drive Wheel (R) for mounting the sanding belt at a later step in the machine's assembly process.

NOTE: There are two threaded holes at the lower end of the upper sanding arm. Assemble the sanding arm to the lower pivot arm with the locking handle using the *UPPER* threaded hole. FIG. 4. This position is for the use of 2" x 72" abrasive belts.

The *LOWER* threaded hole raises the sanding arm for use with longer 2" x 76" sanding belts.

ATTACHING THE PLATEN & TOOL REST ASSEMBLY

The Platen and Tool Rest Assembly (P & Q) attaches to the Pivot Arm (I) with the two hex bolts, lock washers and flat washers (Parts Diagram #10, 1-6, 1-5) that are pre-installed on the pivot arm's two mounting posts. Once attached, the platen and tool rest can be individually adjusted to the sanding belt. FIG. 5.

ADJUSTING THE BELT SANDER PLATEN

The Platen (Parts Diagram #12) is a heavy steel support plate that is positioned behind the sanding belt. Its purpose is to support the belt when sanding. The platen should be adjusted so that it is almost touching the back of the sanding belt. This can be done by loosening the two hex screws (#10) that fasten the back of the platen to the bracket (#11). If the platen is out of alignment for some reason, loosen these two screws, adjust the platen, and re-tighten the two screws. FIG. 5.

To remove the platen for operations such as curved surface sanding, stropping, polishing or other special operations, remove the screws that fasten the back of the platen to the bracket and remove the platen.

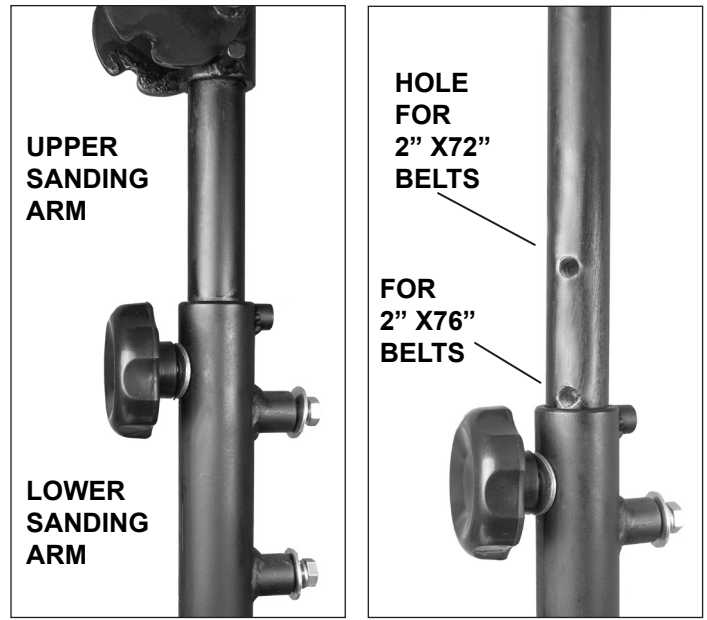

FIG. 4

WARNING THE MACHINE MUST NOT BE PLUGGED IN AND THE POWER SWITCH MUST BE IN THE OFF POSITION UNTIL FULL ASSEMBLY AND ALL ADJUSTMENTS ARE COMPLETE.

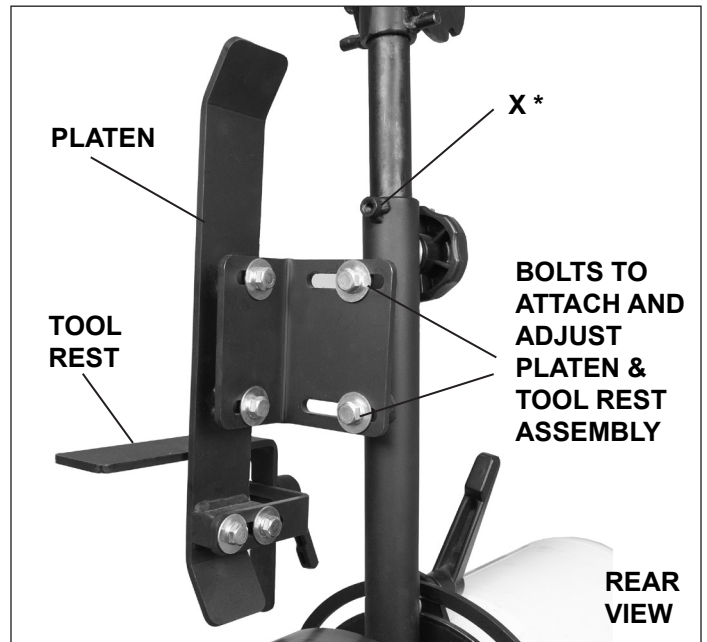

FIG. 5

If necessary, move the bracket away from the belt so that it will not touch the rear of the unsupported belt when 'free sanding' without the platen.

NOTE: * The welded Nut 1/4"x20 at that top of the pivot arm (FIG. 5, X) is for attaching optional dust or safety shields (not included).

ADJUSTMENTS

ADJUSTING THE TOOL REST

The Tool Rest, or Belt Table, is fully adjustable for setting angles to the belt from 90 degrees to over 50 (140) degrees! For most sanding operations, the table will likely remain at a 90° angle to the belt. This and other desired angles can be set by using a square or protractor resting on the tool rest and against the sanding belt and platen.

The Tool Rest (Parts Diagram #14) is pre-assembled onto an Angle Bracket Support (#13) which is fastened to the lower rear of the platen. FIG. 6.

The angle bracket support and the tool rest's angle support both are slotted to allow the tool rest to be moved and set in a variety of positions for working. Loosen the tool rest's Locking Handle (#2-1) and move the tool rest to your desired position, then tighten the locking handle to secure the tool rest in place for sanding. For safety, the tool rest should only be 1/16" away from the sanding belt to prevent projects from being trapped between the rest and belt.

NOTE: To get the full range of table angling, the table-locking handle lever must be very loose, so that it slides along the slots in the brackets. FIG. 7.

SANDING BELT INSTALLATION

1. To install the sanding belt, the spring tension on the Idler Wheel (N, part #9) must be released. This is done by lowering the Tension Lever (L, part #8) into its notched release position on the upper arm. FIG. 8.

2. Install the sanding belt over the top 4" idler wheel, in between the sanding platen and the tool rest, then under the large 8" drive wheel. Make sure that the belt is centered on both the idler and drive wheels.

NOTE: The directional arrow printed on the back of the belt should be pointing in the direction of the belt's rotation on the machine.

3. Apply the preset spring tension to the sanding belt by moving the Tension Lever upward from its released position set in step 1 above. FIG. 9.

4. Before using, make sure that the tool rest is not in contact with the belt and then adjust the belt tracking as described in the following "Belt Tracking" section.

NOTE: To change sanding belts, reverse the steps described above: release belt tension, remove the old belt, install a new belt, apply belt tension, check and set the belt tracking.

⚠ WARNING THE MACHINE MUST NOT BE PLUGGED IN AND THE POWER SWITCH MUST BE IN THE OFF POSITION UNTIL FULL ASSEMBLY AND ALL ADJUSTMENTS ARE COMPLETE.

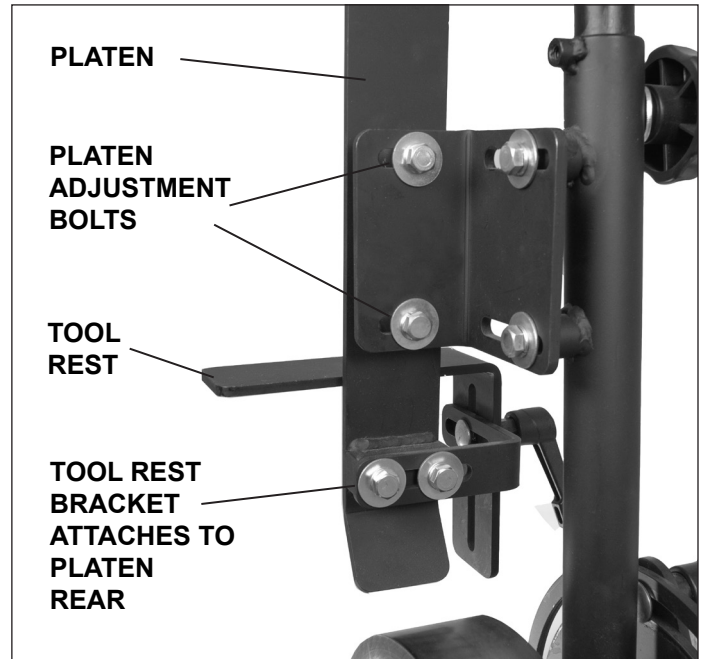

FIG. 6



FIG. 7

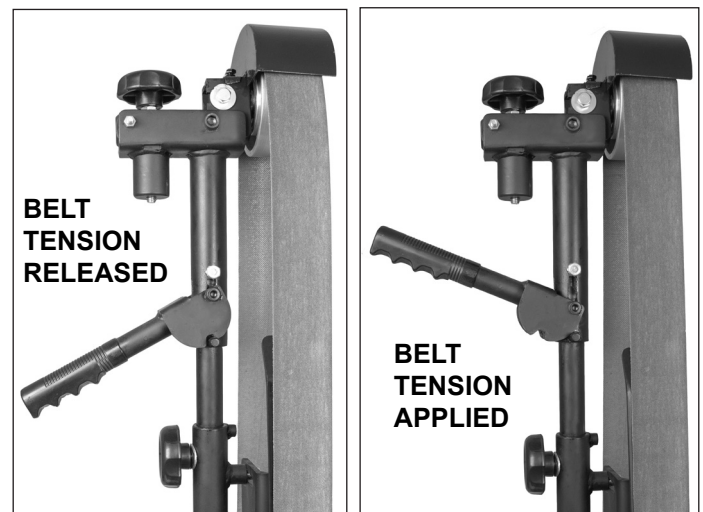

FIG. 8

FIG. 9

ADJUSTMENTS & GENERAL USE

BELT TRACKING

The belt tracking adjustment is set at the factory so that the abrasive belt should run true on the wheels. However, if the belt should track to one side or the other, an adjustment can be made by turning the Tracking Knob (M) which is located at the top of the sanding arm assembly opposite to the idler wheel. FIG. 10.

For safety, test the tracking of the belt by rotating the drive wheel by hand before turning on the motor! If the belt tracks in the center of the wheels, no further adjustments are needed. If the belt tracks off-center, then re-center the belt on the wheels by adjusting the Tracking Knob.

- Turning the knob *clockwise* will cause the belt to track to the left, towards the sanding arm.
- Turning the knob *counterclockwise* will cause the belt to track to the right, away from the sanding arm.

Once the belt stays centered when rotating it by hand, turn on the sander's motor to again check the tracking of the belt while it operates at full speed. Make any needed tracking adjustments with the tracking knob.

BELT SANDING ARM ADJUSTMENT

The #50-272 Belt Sander's sanding arm adjusts 180 degrees, from a forward horizontal position, to 90 degrees upward, to laying backwards horizontally. This allows full user access to working on the 8" rubber-faced drive wheel, with the tool rest and platen, or for free shaping on the belt without the back support of the platen.

To rotate the sanding arm to any angle from a vertical to horizontal position, use the Locking Lever Handle to loosen then secure the pivoting arm in place. FIG. 11.

USING THE BUFFING & SANDING SPINDLE

The 1" diameter x 8" long spindle can be used with buffing wheels or sanding attachments (not included) to finish your projects.

Buffing wheels can be mounted onto the threaded end of the spindle and are held in place with the second set of supplied Flanges (#1-12) and Hex Nut (1-1). FIG. 12.

Long flap or pneumatic sanding accessories slide onto the whole motor spindle and are secured in place with the supplied Flanges and Hex Nut. These accessories are available through craft retailers. Note that they must have 1" arbor holes to fit onto the motor spindle!

⚠ WARNING THE MACHINE MUST NOT BE PLUGGED IN AND THE POWER SWITCH MUST BE IN THE OFF POSITION UNTIL FULL ASSEMBLY AND ALL ADJUSTMENTS ARE COMPLETE.



FIG. 10

⚠ CAUTION Never walk away from the sander when the machine is running. Always lock the switch in the 'OFF' position and unplug the machine from the power supply when not in use.

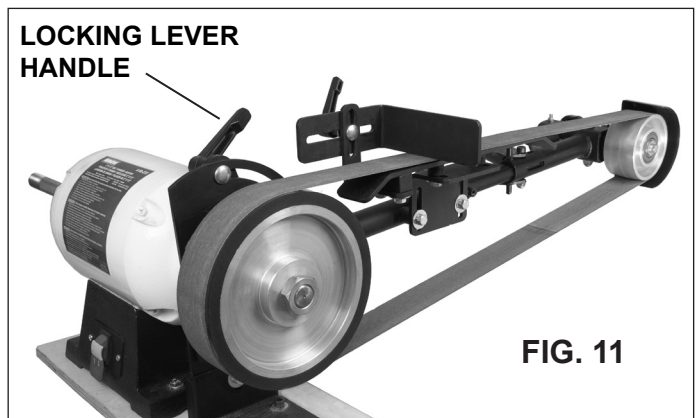

FIG. 11

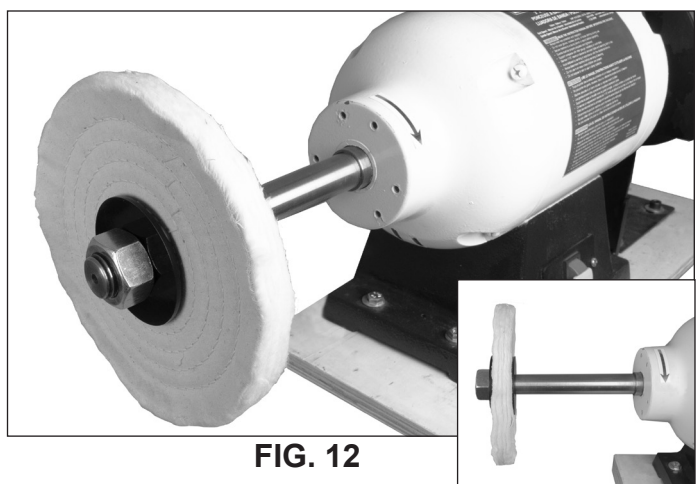

FIG. 12

GENERAL USAGE

Buffing wheels are used for hand held use for polishing, sharpening, and cleaning operations on wood, metal, plastics or composite materials. The rotating fabric can be treated with buffing compounds, paste or waxes to smooth out and polish flat or curved surfaces.

OPERATING THE BUFFER

1. Stand to the side of the machine, turn it "ON" then allow the buffing wheel to come up to a steady speed for at least one minute before any buffing is done.
2. Apply buffing compound, if needed, onto the rim of the spinning buffing wheel. **DO NOT** jam or force the compound bar into the wheel. For final polishing or buffing of waxed surfaces, no compound is needed. Use the untreated cotton buffing wheel to finish polish these pieces.
3. Never force the work piece against the buffing wheel. Allow the buffing wheel time to adjust to the variety of surface shapes of your work piece. Excessive pressure may slow down the rotating wheel and motor. This can cause uneven marks on the work piece and overheat the motor.
4. Check the wheel every few minutes to see the condition of the wheel and buffing compound coating.
 - If the wheel is worn or damaged, remove and replace it immediately.

CAUTION ALWAYS WEAR EYE AND RESPIRATORY PROTECTION! Residue from the buffing wheels and any buffing compound on the wheels are thrown off during use and may cause injury.

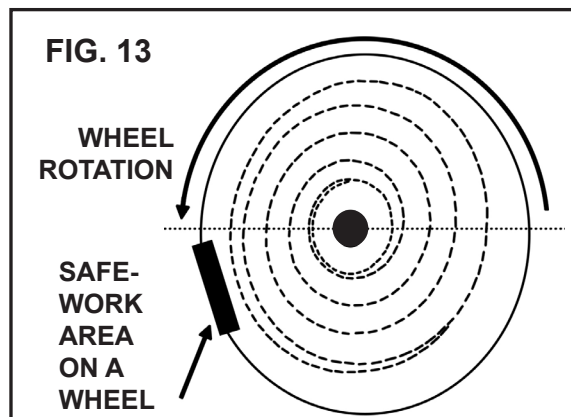

- If the rim surface is glazed over from material residue from buffing, or to apply a new/different grade (color) of compound, use a buffing rake to remove the old compound from the wheel.

NEVER STOP THE BUFFER BY FORCING MATERIAL INTO THE WHEEL. Let the buffer stop rotating on its own.

DO NOT buff using the sides of the wheels.

DO NOT buff using the top or rear of the buffing wheel

ON/OFF SWITCH

WARNING Before turning on the machine, review the safety precautions listed on pages 3 to 6. Make sure that you fully understand the features, adjustments and capabilities of the machine that are outlined throughout this manual.

1. To start the sander, the Power Switch must be in the "OFF" position, with the safety locking key installed in the switch. FIG. 14.
2. When finished working, turn the sander OFF by moving the power switch to the down position.
3. Unplug the Sander from the power source when the machine is not in use for safety measures.

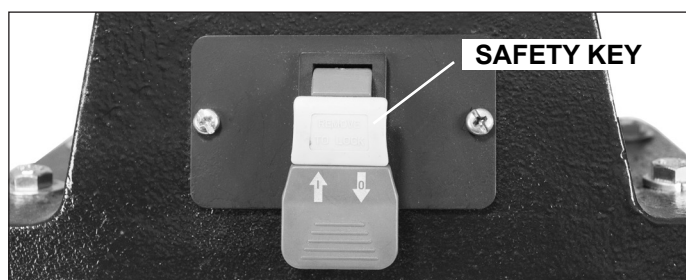

FIG. 14

NOTE: To prevent unauthorized use of the sander, the power switch has a removable locking key. With the power switch in the "OFF" position, pull the locking key out. The sander cannot be turned "ON" with the key removed. Insert the locking key back into the power switch to resume sanding operations.

DUST COLLECTION

Sanding and buffing operations are inherently dusty. To help minimize the amount of dust that escapes into the surrounding air, it is strongly recommended to employ a dust-collection system when using this belt sander. Contact your local woodworking source for obtaining adjustable dust intake nozzels/fittings that can be positioned by the machine for best dust collection. The use of a mask or respirator is still recommended, even when a dust-collection system is in use.

See page 15 for Machine Maintenance Information

TROUBLESHOOTING

Service on these tools should only be performed by an authorized, qualified technician.

SYMPTOM	PROBABLE CAUSE	CORRECTIVE ACTION
Motor will not start.	<ol style="list-style-type: none"> 1. Low voltage 2. Open circuit in motor or loose connections. 3. Blown fuse or breaker 4. Low Temperature 	<ol style="list-style-type: none"> 1. Check power source for proper voltage. 2. Inspect all lead connections on motor for loose or open connections. (Send for Servicing.) 3. Short circuit. Improper match between tool and circuit, fuse or breaker. 4. Start motor at high speed.
<p>Motor will not start – fuses or circuit breakers tripping or blowing.</p> <p>Motor overheats.</p>	<ol style="list-style-type: none"> 1. Short circuit in line, cord or plug. 2. Short circuit in motor or loose connections. 3. Incorrect fuses or circuit breakers in power line. 4. Motor is overloaded. 5. Extension cord is too long and of insufficient gauge (weight). 6. Poor air circulation around the motor 	<ol style="list-style-type: none"> 1. Inspect cord or plug for damaged insulation and shorted wires. 2. Inspect all connections on motor for loose or shorted terminals and/or worn insulation. 3. Install correct fuses or circuit breakers or switch tool to an appropriately sized circuit. 4. Reduce load on motor (pressure on the sandpaper from the object being sanded.) 5. Utilize an extension cord of appropriate gauge and length or plug tool directly into outlet. 6. Reduce the motor run time.
Motor stalls or runs slow - resulting in blown fuses or tripped circuit.	<ol style="list-style-type: none"> 1. Motor is overloaded. 2. Short circuit in the motor or loose connections. 3. Low line voltage. 4. Incorrect fuses or circuit breakers in the power line. 5. Motor capacitor has failed. 6. Belt tension is too tight. 	<ol style="list-style-type: none"> 1. Reduce the load on the motor. 2. Inspect connections on motor for loose or shorted terminals or worn insulation. 3. Correct low voltage conditions (for example: improper extension cord length and/or wire gauge). 4. Install CORRECT fuses or circuit breakers or plug tool into an appropriate circuit, matched to an appropriate fuse or breaker. 5. Replace motor capacitor. 6. Decrease belt tension.
Machine slows down when operating.	<ol style="list-style-type: none"> 1. Feed rate is too great. 2. Undersized circuit or use of undersized extension cord. 	<ol style="list-style-type: none"> 1. Reduce the rate at which the work is fed into the sandpaper. 2. Ensure circuit wires or extension cords are proper gauge, or eliminate use of extension cords.
Machine vibrates excessively or makes excess noise.	<ol style="list-style-type: none"> 1. Incorrect motor mounting. 2. Incorrect sanding-belt tension. 3. Weak or broken belt tension spring. 4. Idler roller is too loose. 5. Broken/defective sanding belt or spindle mounted accessory. 6. Drive belt is too tight 	<ol style="list-style-type: none"> 1. Make sure all fasteners are tightened. 2. Adjust tension-adjustment knob. 3. Replace belt tension spring by service technician. 4. Have service technician adjust idler roller. 5. Replace sanding belt or accessory. 6. Decrease belt tension.

TROUBLESHOOTING

SYMPTOM	PROBABLE CAUSE	CORRECTIVE ACTION
Burn marks on workpiece.	<ol style="list-style-type: none"> 1. Using a sanding grit that is too fine. 2. Using too much pressure. 3. Work held still for too long against the sandpaper. 	<ol style="list-style-type: none"> 1. Use a coarser-grit sandpaper. 2. Reduce work piece pressure on the sandpaper while sanding. 3. Do not keep the work piece sanding in one place for too long.
Deep sanding grooves or scars in work piece.	<ol style="list-style-type: none"> 1. Sanding belt grit is too coarse for the desired finish. 2. Work piece is being sanded across the grain. 3. Too much sanding force on the work piece. 4. Work piece held still against the belt for too long. 	<ol style="list-style-type: none"> 1. Use a finer-grit sanding belt. 2. Sand with the grain of the wood. 3. Reduce pressure on workpiece while sanding. 4. Keep work piece moving while sanding.
Sanding surface clogs quickly	<ol style="list-style-type: none"> 1. Too much pressure against the belt. 2. Sanding softwood or highly resinous woods. 	<ol style="list-style-type: none"> 1. Reduce pressure on work piece while sanding. 2. Use different stock, sanding grits, or accept that this will happen and plan on cleaning or replacing belts frequently.
Sanding grains easily rub off the belt.	<ol style="list-style-type: none"> 1. Sandpaper has been stored in an incorrect environment. 2. Sandpaper has been damaged or folded. 	<ol style="list-style-type: none"> 1. Ensure sandpaper is stored away from extremely hot & dry or damp/humid conditions. 2. Store sanding accessories flat – not bent or folded.
Workpiece lifts up from the sanding table.	<ol style="list-style-type: none"> 1. Rotation of the belt must be down towards the table. Motor wiring may be incorrect. 	<ol style="list-style-type: none"> 1. Have service technician check motor wiring connections so belt rotates down towards the table.

MAINTENANCE

⚠ WARNING: Turn the power switch “OFF” and disconnect the plug from the outlet prior to adjusting or maintaining the sander. DO NOT attempt to repair or maintain the electrical components of the motor. Take the sander to a qualified service technician for this type of maintenance.

MAINTENANCE REQUIRED

- | | |
|---------------------------------------------------------------------------------------|------------------|
| 1. Check the power cord for any damage. | Before each use. |
| 2. Check sanding belts and any added spindle accessories for damage. | Before each use. |
| 3. Check all guards and hardware to make sure they are secure. | Before each use. |
| 4. Check all moving parts for alignment and binding issues. | Before each use. |
| 4. Dress/Clean sanding surfaces for best abrasive action. | As needed |
| 5. Replace sanding belts or spindle accessories when worn or damaged. | As needed. |
| 6. Clean and vacuum dust from the motor housing and other sander parts. | As needed. |
| 7. Ball bearings are grease packed at the factory and require no further lubrication. | |

Service beyond recommended maintenance on these tools should only be performed by an authorized, qualified technician.

WIRING DIAGRAM

⚠ WARNING: This machine must be grounded. Replacement of the power supply cable should only be done by a qualified electrician. See page 5 for additional electrical information.

As received from the factory, your machine is ready to run at 110V operation. It can be switched to 220V according to the schematic below. The illustration on page 5 shows the type of 220V, 3-wire electrical plug and receptacle that has a grounding conductor that is required.

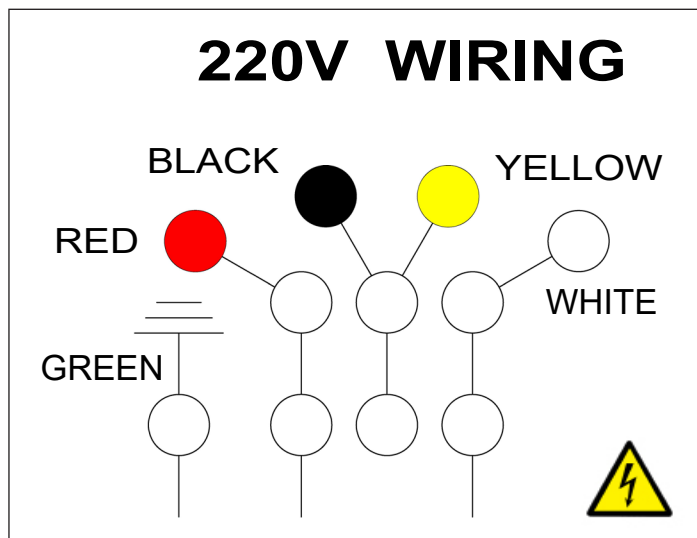
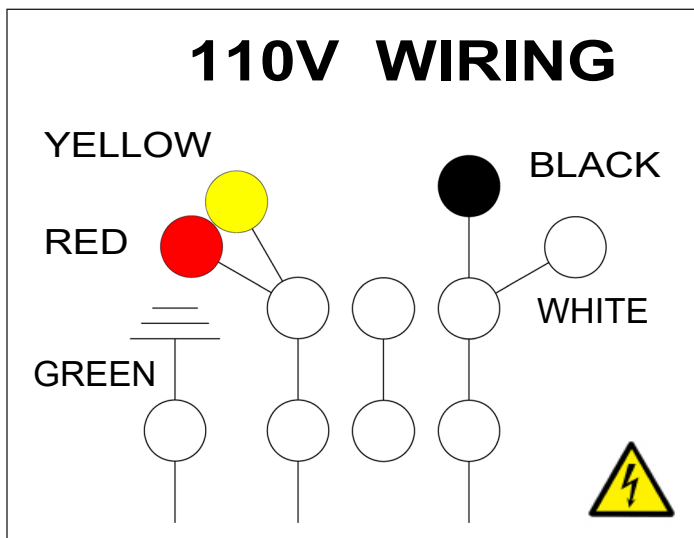

NOTE: THE WIRES DEPICTED ARE LEADING INTO THE MOTOR

WARRANTY

RIKON

POWER TOOLS®

5-Year Limited Warranty

RIKON Power Tools Inc. ("Seller") warrants to only the original retail consumer/purchaser of our products that each product be free from defects in materials and workmanship for a period of five (5) years from the date the product was purchased at retail. This warranty may not be transferred.

This warranty does not apply to defects due directly or indirectly to misuse, abuse, negligence, accidents, repairs, alterations, lack of maintenance or normal wear and tear. Under no circumstances will Seller be liable for incidental or consequential damages resulting from defective products. All other warranties, expressed or implied, whether of merchantability, fitness for purpose, or otherwise are expressly disclaimed by Seller. This five-year warranty does not cover products used for commercial, industrial or educational purposes. The warranty term for these claims will be limited to a two-year period.

This limited warranty does not apply to accessory items such as blades, drill bits, sanding discs, grinding wheels, belts, guide bearings and other related items.

Seller shall in no event be liable for death, injuries to persons or property, or for incidental, contingent, special, or consequential damages arising from the use of our products.

To take advantage of this warranty, proof of purchase documentation must be provided which has the date of purchase and an explanation of the complaint.

The Seller reserves the right to effect at any time, without prior notice, those alterations to parts, fittings, and accessory equipment which they may deem necessary for any reason whatsoever.

To register your machine online, visit RIKON at www.rikontools.com/warranty

To take advantage of this warranty, or if you have any questions, please contact us at 877-884-5167 or email warranty@rikontools.com

ASSEMBLY

50-272 BELT SANDER/GRINDER MOUNTING DIAGRAM

The 50-272 Belt Sander/Buffer has two parts, motor and belt assemblies. Once assembled together, they must be mounted securely to a workbench or stand before operation can begin. The diagram below shows the location of holes that must be bored in your bench or stand for the machine. We suggest that before any drilling is done, set the machine on your work surface to find the best position for your work needs. With a pencil, mark spots through the motor and belt base holes to give you approximate locations for then marking out the exact dimensions shown on the mounting diagram. This will ensure that the Sander/Grinder is installed right where you want it. **NOTE:** Mounting hardware is not included.

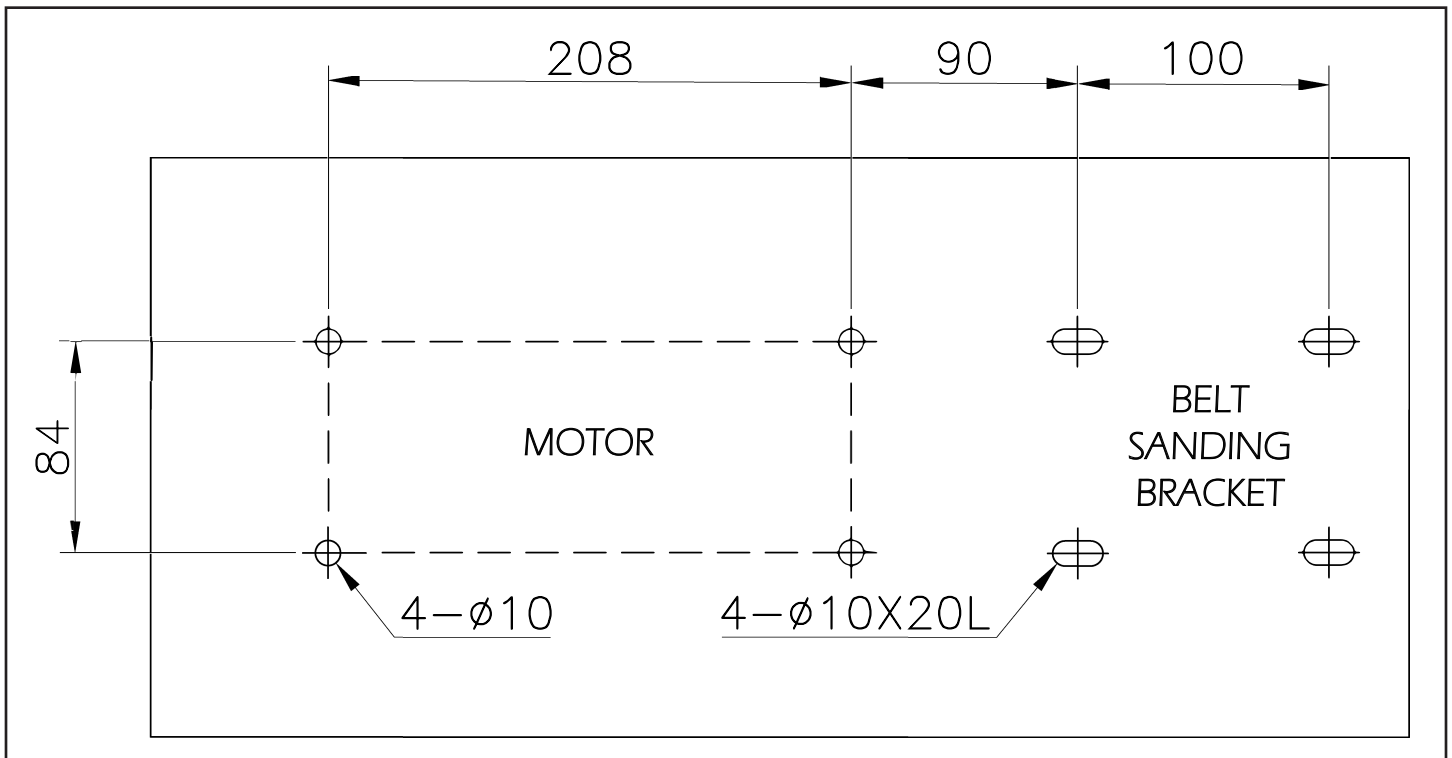

ACCESSORIES

SANDING BELTS

2" x 72" Zirconia Alumina abrasives, resin bonded with grinding aid.

Industrial grade for heavy duty stock removal of metal and other hard materials. Self-sharpening abrasives with added grinding aid assists in keeping the belt clean, improves the cutting action and extending belt life.

- 50-2036Z** 36 grit
- 50-2060Z** 60 grit
- 50-2080Z** 80 grit
- 50-2120Z** 120 grit



BUFFING WHEELS

8" Diameter x 1/2" thick with 1" Arbor Holes.

Bufs are ideal to use for final polishing of waxed wood bowls and various composite materials, putting mirror shining finishes on metal parts, or creating micro-fine edges on woodworking tools.

Spiral Sewn Cotton for light buffing and polishing operations.

C81-801 Each

Spiral Sewn Course Cotton for more aggressive cleaning and polishing of metals and other materials.

C81-802 Each



PARTS DIAGRAM

50-272 BELT SANDER / BUFFER

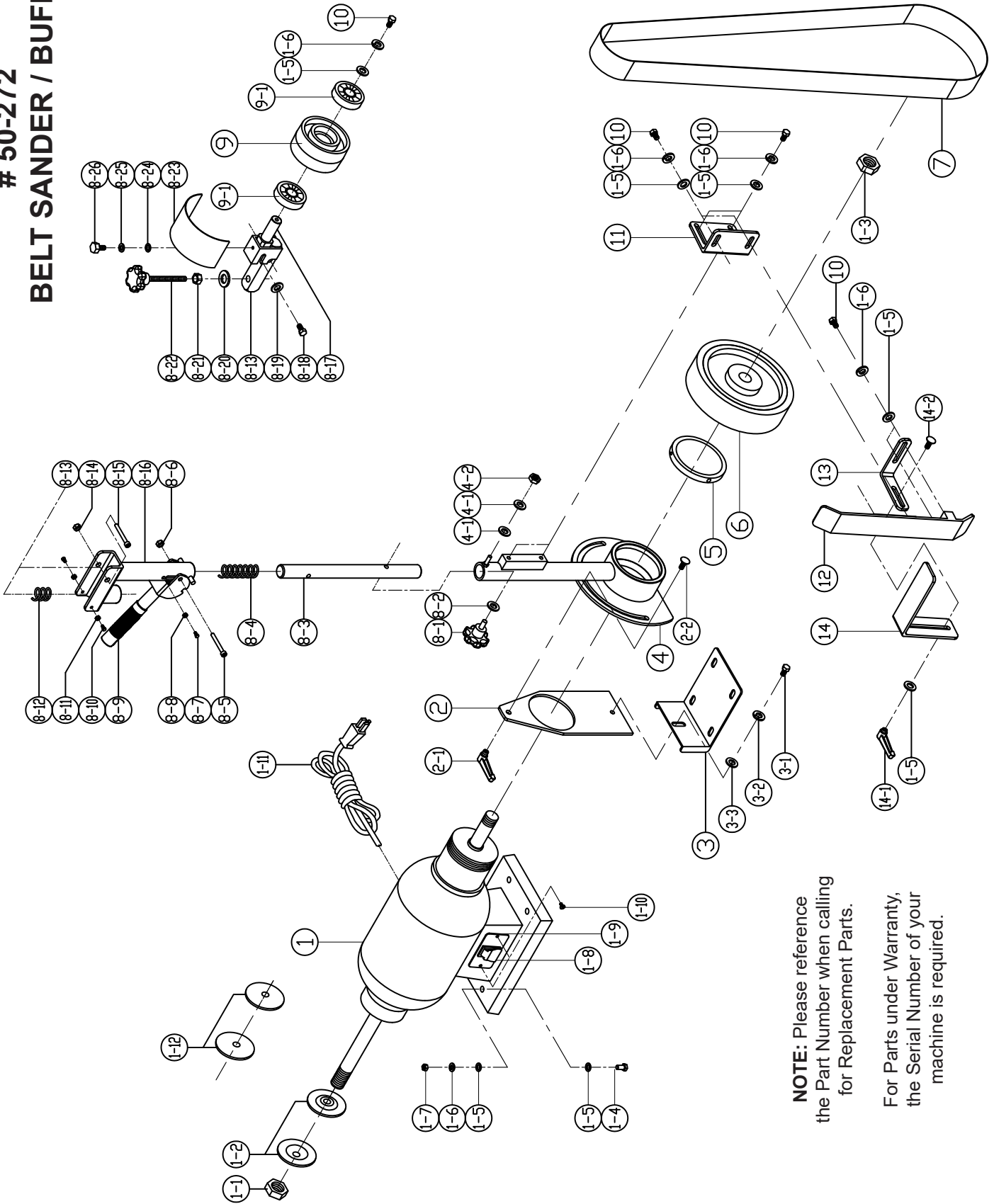

NOTE: Please reference the Part Number when calling for Replacement Parts.

For Parts under Warranty, the Serial Number of your machine is required.

50-272 BELT SANDER / BUFFER

PARTS LIST

KEY NO.	DESCRIPTION	QTY.	PART NO.	KEY NO.	DESCRIPTION	QTY.	PART NO.
1	MOTOR 1HP, 110V/220V, 1PH, 60HZ	1	P50-272-1	8-5	CAP SCREW 5/16" X 2-1/4"L	1	P50-272-8-5
1-1	HEX NUT 1"-8 UNC L.H.	1	P50-272-1-1	8-6	NYLON NUT 5/16"	1	P50-272-8-6
1-2	WHEEL FLANGE	2	P50-272-1-2	8-7	HEX SCREW 5/16" X 3/4"L	1	P50-272-8-7
1-3	HEX NUT 1"-8 UNC R.H.	1	P50-272-1-3	8-8	HEX NUT 5/16"	1	P50-272-8-8
1-4	HEX SCREW 5/16" X 1-3/4" L	4	P50-272-1-4	8-9	TENSION HANDLE	1	P50-272-8-9
1-5	WASHER 5/16"	16	P50-272-1-5	8-10	HEX SCREW 1/4" X 3/4"L	2	P50-272-8-10
1-6	SPRING WASHER 5/16"	11	P50-272-1-6	8-11	HEX NUT 1/4"	2	P50-272-8-11
1-7	HEX NUT 5/16"	4	P50-272-1-7	8-12	COMPRESSION SPRING	1	P50-272-8-12
1-8	ON/OFF POWER SWITCH	1	P50-272-1-8	8-13	PIVOT BRACKET	1	P50-272-8-13
1-9	SWITCH PLATE	1	P50-272-1-9	8-14	NYLON NUT 3/8"	1	P50-272-8-14
1-10	PAN MACHINE SCREW 3/16" X 1/4" L	2	P50-272-1-10	8-15	CAP SCREW 3/8" X 2-1/2"L	1	P50-272-8-15
1-11	POWER CORD 3x16 AWG, 76"	1	P50-272-1-11	8-16	TRACKING BRACKET	1	P50-272-8-16
1-12	WHEEL FLANGE	2	P50-272-1-12	8-17	AXLE	1	P50-272-8-17
2	PIVOT BRACKET	1	P50-272-2	8-18	HEX SCREW 5/16" X 5/8"L	1	P50-272-8-18
2-1	LOCK LEVER 3/8"	1	P50-272-2-1	8-19	WASHER 5/16"	1	P50-272-8-19
2-2	CARRIAGE BOLT 3/8" X 3/4" L	1	P50-272-2-2	8-20	WASHER 3/8"	1	P50-272-8-20
3	PIVOT ARM MOUNTING BRACKET	1	P50-272-3	8-21	HEX NUT 3/8"	1	P50-272-8-21
3-1	HEX SCREW 3/8" X 3/4" L	1	P50-272-3-1	8-22	KNOB 3/8" X 2-1/2"L	1	P50-272-8-22
3-2	SPRING WASHER 3/8"	1	P50-272-3-2	8-23	WHEEL GUARD	1	P50-272-8-23
3-3	WASHER 3/8"	1	P50-272-3-3	8-24	WASHER 1/4"	1	P50-272-8-24
4	PIVOT ARM	1	P50-272-4	8-25	SPRING WASHER 1/4"	1	P50-272-8-25
4-1	WASHER 1/4"	2	P50-272-4-1	8-26	HEX SCREW 1/4" X 3/8"L	1	P50-272-8-26
4-2	HEX NUT 1/4"	1	P50-272-4-2	9	IDLER WHEEL	1	P50-272-9
5	WHEEL FLANGE	1	P50-272-5	9-1	BEARING 6204 RZ	2	P50-272-9-1
6	DRIVE WHEEL	1	P50-272-6	10	HEX SCREW 5/16" X 5/8"L	7	P50-272-10
7	SANDING BELT 2" X 72"	1	P50-272-7	11	PLATEN BRACKET	1	P50-272-11
8	BELT TENSION LEVER SET	1	P50-272-8	12	PLATEN	1	P50-272-12
8-1	KNOB 3/8" X 1" L	1	P50-272-8-1	13	TOOL REST SUPPORT	1	P50-272-13
8-2	WAVE WASHER 3/8"	1	P50-272-8-2	14	TOOL REST	1	P50-272-14
8-3	SHAFT	1	P50-272-8-3	14-1	LOCK LEVER 5/16"	1	P50-272-14-1
8-4	COMPRESSION SPRING	1	P50-272-8-4	14-2	CARRIAGE BOLT 5/16" X 3/4" L	1	P50-272-14-2

NOTE: Please reference the Manufacturer's Part Number when calling for Replacement Parts.
For Parts under Warranty, the Serial Number of your machine is required.



For more information:
25 Commerce Way
North Andover, MA 01845

877-884-5167 / 978-528-5380
techsupport@rikontools.com

Link to
RIKON's
website

